

Pressure controls, type KP

Introduction

KP pressure controls are for use in refrigeration and air conditioning systems to give protection against excessively low suction pressure or excessively high discharge pressure.

KP pressure controls are also used for starting and stopping refrigeration compressors and fans on air-cooled condensers.

KP pressure controls are fitted with a single-pole double-throw (SPDT) switch. The position of the switch is determined by the pressure control setting and the pressure at the connector.

KP pressure controls are available in IP 30 and IP 44 enclosures.



Features

- Ultra-short bounce times
- Reduces wear to a minimum and increases reliability.
- Manual control
- Electrical contact function can be tested without the use of tools.
- KP 2 with low differential for low-pressure regulation
- KP 6 for HP refrigerants (R 410A, CO₂)
- KP 6, 7 and 17 with fail-safe bellows element
- Vibration and shock resistant
- Compact design
- Fully welded bellows element
- High reliability both electronically and mechanically.

Approvals

CE-marked in accordance with LVD 73/23/EC and EN 60947-4-5 for sale in Europe.

KP 1, 2, 6, 7 and KP 17: CE marked in accordance with PED 97/23/EC, category IV, safety equipment and EN 12263, DIN 32733

Germanischer Lloyd, Germany

UL approval for USA and Canada

DNV, Det Norske Veritas, Norway

RINA, Registro Italiano Navale, Italy

BV, Bureau Veritas, France

LR, Lloyd's Register, UK

RMRS, Russian Maritime Register of Shipping, Russia

CCC, China Compulsory Certificate

Materials in contact with the medium

Unit type	Material
KP 1, 2, 5, 6, 7, 15 and 17	Tinbronze, no. 2.1020 to DIN 17662 Free cutting steel, no. 1.0737 / 1.0718 to DIN 1651
KP 1A, 5A, 6, 7A and 15A only	Stainless steel 18/8, no. 1.0737 / 1.0718 to DIN 17440 Free cutting steel, no. 1.0719 to DIN 1651 Steel, no. 1.0330 to DIN 1624 Aluminium, no. 3.0255 to DIN 1712

Technical data

Ambient temperature
 -40 → +65°C (+80°C for max. 2 hours).

DIN-approved units:
 -25 → +65°C (+80°C for max. 2 hours).

Max. working pressure

LP: PB = 17 bar
 HP: PB = 35 bar
 KP 6: PB = 46.5 bar

Max. test pressure

LP: p' = 20 bar
 HP: p' = 35 bar
 KP 6: p' = 46.5 bar

Contact load

Alternating current:
 AC1: 16 A, 400 V
 AC3: 16 A, 400 V
 AC15: 10 A, 400 V
 Max. starting current (L.R.): 112 A, 400 V

Direct current:

DC13: 12 W, 220 V control current

Properties according to EN 60947:

Wire dimensions	
solid/stranded	0.75 - 2.5 mm ²
flexible, w/out ferrules	0.7 - 2.5 mm ²
flexible, with ferrules	0.5 - 1.5 mm ²
Tightning torque	max. 2 NM
Rated impulse voltage	4 kV
Pollution degree	3
Short circuit protection, fuse	20 Amp
Insulation	400 V
IP	30/44

Cable connection

The cable entry can be used for 6 → 14 mm dia. cables.
 A Pg 13.5 screwed cable entry can also be used for 6 → 14 mm cable. With 8 → 16 mm cable a standard Pg 16 screwed cable entry can be used.

Enclosure

IP 30 to EN 60529 / IEC 60529
 Enclosure IP 30 is obtained when the units without top cover are mounted on a flat surface or bracket. The bracket must be fixed to the unit so that all unused holes are covered.

IP 44 to EN 60529 / IEC 60529

Enclosure IP 44 is obtained when the units with top cover are mounted on a flat surface or bracket. The bracket must be fixed to the unit so that all unused holes are covered.
 KP pressure controls with auto reset are supplied with top cover. For KP pressure controls with manual reset, the top cover must be separately ordered.

Contact systems

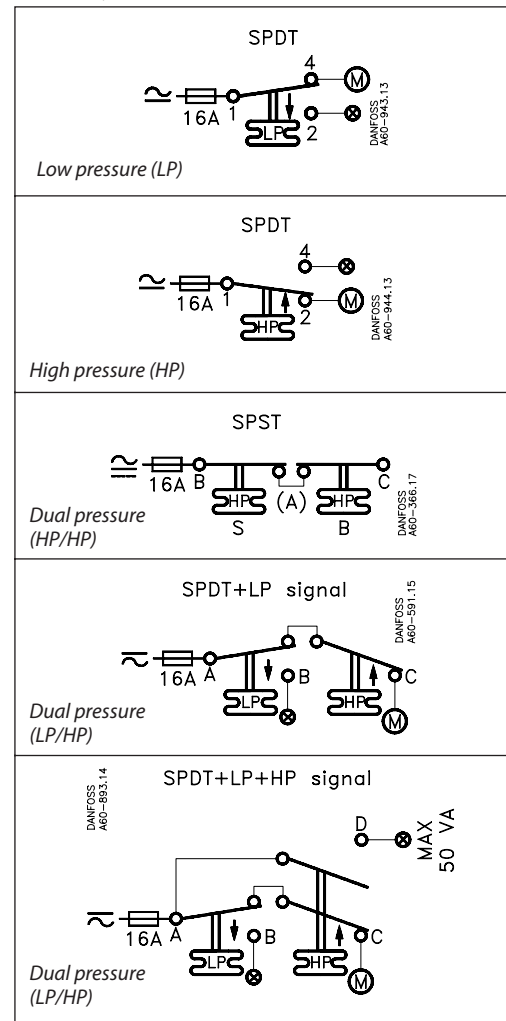

IP 55 to EN 60529 / IEC 60529
 IP 55 is obtained when the KP pressure controls are mounted in an IP 55 enclosure, (**code no. 060-033066** for single pressure controls and **code no. 060-035066** for dual pressure controls). IP 55 enclosure has to be ordered separately.

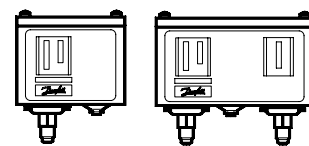

Ordering

Pressure	Type	Low pressure (LP)		High pressure (HP)		Reset		Contact system	Code no.		
		Regulating range bar	Differential Δp bar	Regulating range bar	Differential Δp bar	Low pressure LP	High pressure HP		¼ in. 6 mm flare	¼ in. ODF solder	6 mm ODF solder

For fluorinated refrigerants

Low	KP 1	-0.2 → 7.5	0.7 → 4.0			Aut.		SPDT	060-110166 ³⁾	060-111266 ³⁾	060-111066 ³⁾
Low	KP 1	-0.2 → 7.5	0.7 → 4.0			Aut.			060-114166 ¹⁾³⁾		
Low	KP 1	-0.9 → 7.0	Fixed 0.7			Man.			060-110366	060-111166	060-110966
Low	KP 2	-0.2 → 5.0	0.4 → 1.5			Aut.			060-112066 ³⁾		060-112366 ³⁾
High	KP 5			8 → 32	1.8 → 6.0		Aut.		060-117166 ³⁾	060-117966 ³⁾	060-117766 ³⁾
High	KP 5			8 → 32	Fixed 3		Man.	060-117366	060-118066	060-117866	
Dual	KP 15	-0.2 → 7.5	0.7 → 4.0	8 → 32	Fixed 4	Aut.	Aut.	SPDT + LP signal	060-124166 ³⁾	060-125466 ³⁾	
Dual	KP 15	-0.2 → 7.5	0.7 → 4.0	8 → 32	Fixed 4	Aut.	Man.		060-124366		
Dual	KP 15	-0.2 → 7.5	0.7 → 4.0	8 → 32	Fixed 4	Aut.	Man.		060-114866 ¹⁾		
Dual	KP 15	-0.9 → 7.0	Fixed 0.7	8 → 32	Fixed 4	Man.	Man.		060-124566		
Dual	KP 15	-0.9 → 7.0	Fixed 0.7	8 → 32	Fixed 4	Conv. ²⁾	Conv. ²⁾		060-126166		
Dual	KP 15	-0.2 → 7.5	0.7 → 4.0	8 → 32	Fixed 4	Aut.	Aut.	SPDT + LP and HP signal	060-126566 ³⁾	060-129966 ³⁾	
Dual	KP 15	-0.2 → 7.5	0.7 → 4.0	8 → 32	Fixed 4	Aut.	Man.		060-126466	060-128466	
Dual	KP 15	-0.2 → 7.5	0.7 → 4.0	8 → 32	Fixed 4	Conv. ²⁾	Conv. ²⁾		060-115466 ³⁾	060-001066 ³⁾	
Dual	KP 15	-0.9 → 7.0	Fixed 0.7	8 → 32	Fixed 4	Conv. ²⁾	Conv. ²⁾		060-122066		

Pressure	Type	Low pressure (LP)		High pressure (HP)		Reset	Contact system	Code no.	
		Regulating range bar	Differential Δp bar	Regulating range bar	Differential Δp bar			M10 × 0.75	1 m cap. tube with M10 × 0.75

For fluorinated refrigerants and R 717 (NH₃)

Low	KP 1A	-0.2 → 7.5	0.7 → 4.0			Aut.	SPDT	060-116266	060-116066 ³⁾
Low	KP 1A	-0.9 → 7.0	Fixed 0.7			Man.		060-116166	
High	KP 5A			8 → 32	1.8 → 6.0	Aut.		060-123066 ³⁾	
High	KP 5A			8 → 32	Fixed 3	Man.		060-115366	060-123166
Dual	KP 15A	-0.2 → 7.5	0.7 → 4.0	8 → 32	Fixed 4	Aut./Aut.	SPDT + LP and HP signal	060-129566	060-129366 ³⁾
Dual	KP 15A	-0.2 → 7.5	0.7 → 4.0	8 → 32	Fixed 4	Aut./Man.		060-129666	060-129466
Dual	KP 15A	-0.9 → 7.0	Fixed 0.7	8 → 32	Fixed 4	Conv./Conv. ²⁾	SPDT LP signal		060-128366

¹⁾ Pressure controls with gold-plated contacts

²⁾ Conv.: optional automatic or manual reset

³⁾ Enclosure IP 44

Accessories for KP pressure controls with M10 × 0.75 connections:

Weld connections: M10 × 0.75 nut and Ø6 × 150 mm seamless steel pipe,

Steel cap. tube: 1 m with 2 × M10 × 0.75 nuts,

Steel cap. tube: 1 m with 1 × M10 × 0.75 and G 3/8 nut,

Adaptor: M 10 × 0.75 1/4 to 1/8 NPT int. thread,

IP 55 enclosure for single pressure controls,

IP 55 enclosure for dual pressure controls,

code no. 060-005766

code no. 060-007866

code no. 060-008266

code no. 060-014166

code no. 060-033066

code no. 060-035066

For other accessories: see "Spare parts and accessories", RX5AB302

Ordering
(continued)

Pressure control setting with convertible reset

Low press.	Manual reset ¹⁾	Automatic reset	Automatic reset	Manual reset
High press.	Manual reset ¹⁾	Manual reset	Automatic reset	Automatic reset

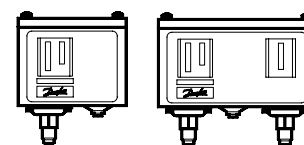
¹⁾ Factory setting

Pressure controls with EN 12263 and DIN 32733 approval ¹⁾

Pressure	Type ²⁾	Low pressure (LP)		High pressure (HP)		Reset	Contact system	Code no.	
		Regulating range bar	Differential Δp bar	Regulating range bar	Differential Δp bar			$\frac{1}{4}$ in. 6 mm flare	6 mm ODF solder
						LP/HP			

For fluorinated refrigerants

Low	KP 1	-0.2 → 7.5	0.7 → 4.0			Aut.	SPDT	060-110166³⁾	060-111066³⁾
Low	KP 1	-0.9 → 7	Fixed 0.7			Man.	SPDT	060-110366	060-110966
Low	KP 1	-0.5 → 3.0	Fixed 0.7			Aut.	SPDT		060-111766
Low	KP 2	-0.2 → 5	0.4 → 1.5			Aut.	SPDT	060-112066³⁾	060-112366³⁾
High	KP 6W			8 → 42	4 → 10	Aut.	SPDT	060-519066³⁾	
High	KP 6B			8 → 42	Fixed 4	Man.	SPDT	060-519166	
High	KP 7W			8 → 32	4 → 10	Aut.	SPDT	060-119066³⁾	060-120366³⁾
High	KP 7B			8 → 32	Fixed 4	Man.	SPDT	060-119166	
High	KP 7S			8 → 32	Fixed 4	Man.	SPDT	060-119266³⁾	
Dual	KP 7BS			8 → 32	Fixed 4	Man. / Man.	SPST	060-120066	
Dual	KP 17W	-0.2 → 7.5	0.7 → 4	8 → 32	Fixed 4	Aut. / Aut.	SPDT + LP and HP signal	060-127566³⁾	060-127666³⁾
Dual	KP 17W	-0.2 → 7.5	0.7 → 4	8 → 32	Fixed 4	Aut. / Aut.	SPDT	060-126766³⁾	
Dual	KP 17B	-0.2 → 7.5	0.7 → 4	8 → 32	Fixed 4	Aut. / Man.	SPDT	060-126866	060-127466
Dual	KP 17WB	-0.2 → 7.5	0.7 → 4	8 → 32	Fixed 4	Aut./Conv. ⁵⁾	SPDT + LP and HP signal	060-539766³⁾⁴⁾	

Pressure controls with EN 12263 and DIN 32733 approval ¹⁾

Pressure	Type ²⁾	Low pressure (LP)		High pressure (HP)		Reset	Contact system	Code no.	
		Regulating range bar	Differential Δp bar	Regulating range bar	Differential Δp bar			M10 × 0.75	1 m cap. tube with M10 × 0.75
						LP/HP			

For ammonia

Low	KP 1A	-0.2 → 7.5	0.7 → 4.0			Aut.	SPDT	060-116266	060-116066³⁾
Low	KP 1A	0.9 → 7	Fixed 0.7			Man.	SPDT		060-116166
High	KP 7ABS			8 → 32	Fixed 4	Man./Man.	SPST		060-120566

¹⁾ Meets the requirements in VBG 20 dealing with safety equipment and excess pressures.

KP 1, 2, 6, 7 and KP 17 are CE marked acc. to PED, Pressure Equipment Directive.

²⁾ W = Wächter (pressostat), B = Begrenzer (pressure control with ext. reset), S = Sicherheitsdruckbegrenzer (pressure control with int. reset).

³⁾ Enclosure IP 44

⁴⁾ factory setting: LP side: Range 1 bar Pe, Diff. 1 bar; HP side: Range 18 bar Pe, Diff. 4 bar fixed

⁵⁾ Conv.: optional automatic or manual reset

Design / Function

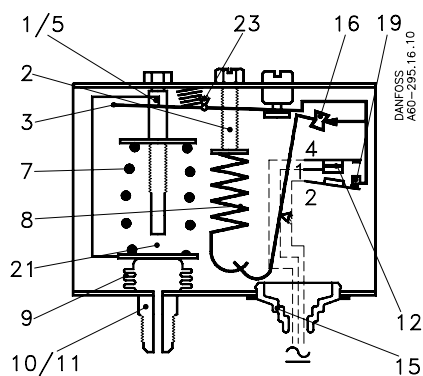

Key sketch of KP pressure control

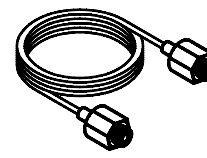

Capillary tube

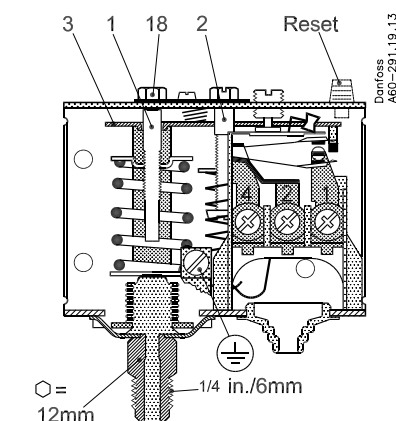

KP 1

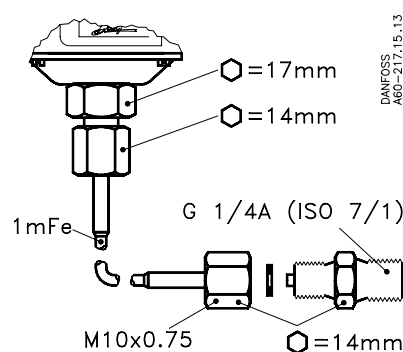

Capillary tube for KP 1A, 5A and 15A

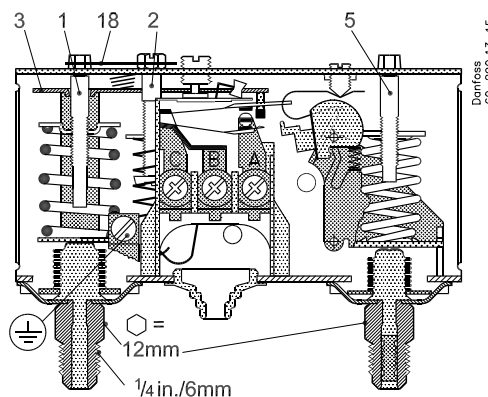

KP 15

- 1. Low pressure (LP) setting spindle
- 2. Differential setting spindle, LP
- 3. Main arm
- 5. High pressure (HP) setting spindle
- 7. Main spring
- 8. Differential spring
- 9. Bellows
- 10. LP connection
- 11. HP connection
- 12. Switch
- 13. Terminals
- 14. Earth terminal
- 15. Cable entry
- 16. Tumbler
- 18. Locking plate
- 19. Arm
- 30. Reset button

The switch in the KP has a snap-action function and the bellows moves only when the cut-in or cut-out value is reached.

The bellows becomes connected to the low or high pressure side of the plant through connection (10) or (11).

The design of the KP affords the following advantages:

- high contact load
- ultra-short bounce time
- high resistance to pulsation
- vibration resistance up to 4 g in the range 0-1000 Hz
- long mechanical and electrical life

Design
(continued)

KP1, KP1A, KP2, KP6, KP6A, KP7 and KP17 units with designation W, B or S have been tested and approved by TÜV, Rheinland in accordance with DIN 32733 and EN 12263

- W = Wächter (pressure control)
- B = Begrenzer
(pressure control with external reset)
- S = Sicherheitsdruckbegrenzer
(pressure control with internal reset).

KP6, KP6A, KP7 and KP17 have a double bellows: an outer bellows and a regulating bellows. When system pressure exceeds the set value, the KP will automatically stop the plant. The double bellows system prevents loss of charge in the event of bellows rupture.

A rupture in the inner bellows will cause the control cut-out pressure to fall about 3 times less the set value, thus the refrigeration plant compressor will stop.

A rupture in the outer bellows will cause the

control cut-out pressure to fall to about 3 bar under the set value, thus providing a fail-safe function.

Versions with designation W or AW cut in again automatically when the pressure has fallen to the set value minus the differential.

Versions with designation B or AB can be cut in manually with the external reset button when the pressure in KP1 has raised 0.7 bar above set value and in KP6 and KP7 has fallen 4 bar under the set value.

Versions with designation S or AS can be cut in manually with the internal reset arm when the pressure has fallen 4 bar under the set value. All KP pressure controls, including those which are PED-approved, operate independently of changes in the ambient temperature around the control housing. Therefore the set cut-out pressure and differential are held constant provided the permissible ambient temperatures are not exceeded.

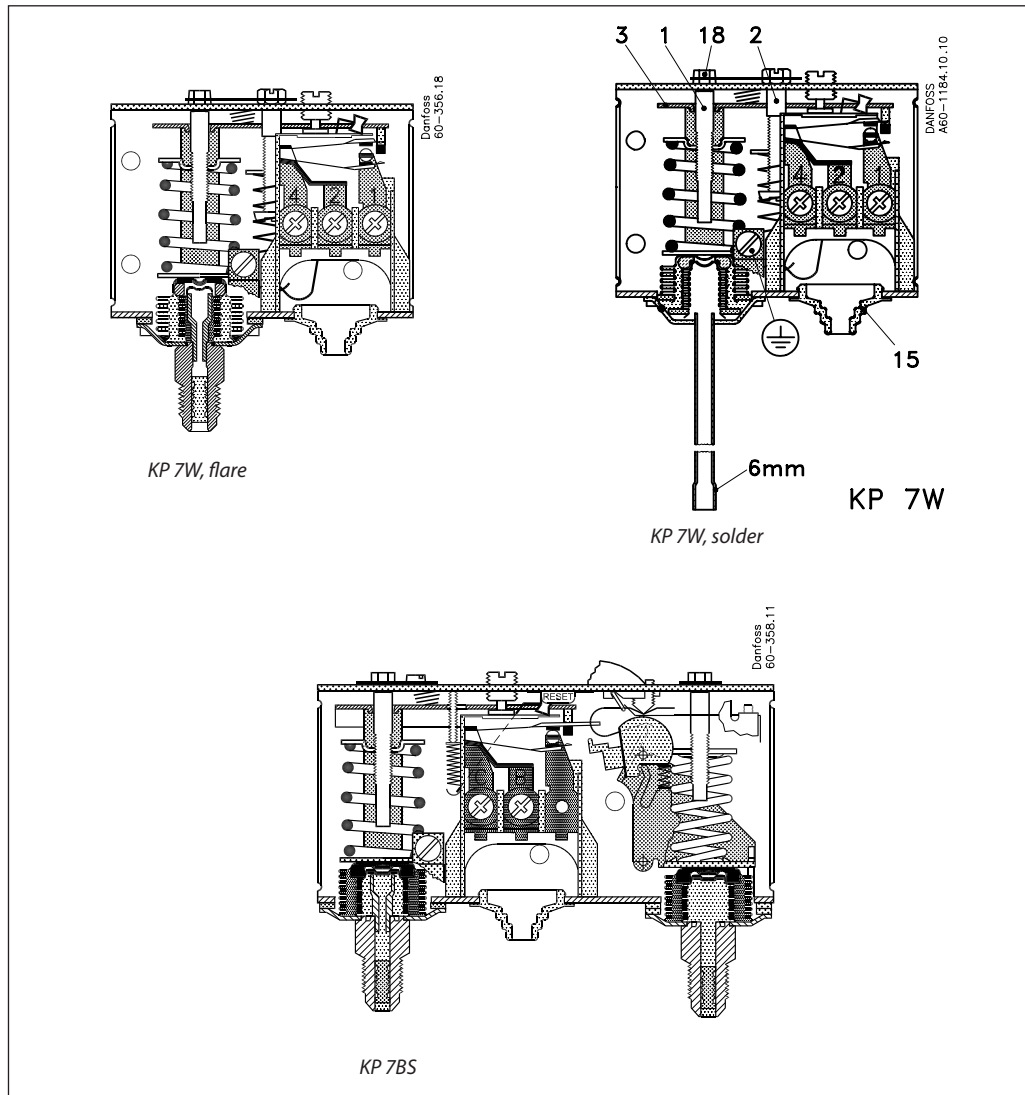

- 1. Pressure setting spindle
- 2. Differential setting spindle
- 3. Main arm
- 5. Pressure setting spindle, DBK
- 15. Cable entry
- 18. Locking plate
- 19. Arm
- 25. Int. reset arm
- 30. Ext. reset button

Terminology

Reset

1. *Manual reset:*
Units with manual reset can only be reset during operation by activation of the reset button.
2. *Automatic reset:*
After operational stop, these units reset automatically.
3. *Convertible reset:*
Units with optional reset can be activated by automatic and/or manual reset.

Permissible working pressure

The permissible working pressure is determined by the pressure that can be safely allowed in the refrigerating system or any of the units within it. The permissible working pressure is designated PB (Der zulässige Betriebsüberdruck).

Test pressure

The test pressure is the pressure used in strength tests and/or leakage tests on refrigerating systems or individual parts in systems. The test pressure is designated p_t.

"Snap function"

A certain contact force is maintained until irrevocable "snap" is initiated. The time during which the contact force approaches zero is thus limited to a very few milliseconds. Therefore contact bounce cannot occur as a result of, for example, slight vibrations, before the cut-out point. Contact systems with "Snap function" will change over even when micro-welds are created between the contacts during cut-in. A very high force is created during cut-out to separate the contacts. This force immediately shears off all the welds. Thus the cut-out point of the unit remains very accurate and completely independent of the magnitude of the current load.

Setting

Pressure controls with automatic reset - LP:

Set the LP start pressure on the "CUT-IN" scale (range scale).

One rotation of the low pressure spindle ~ 0.7 bar.

Set the LP differential on the "DIFF" scale. One rotation of the differential spindle ~ 0.15 bar.

The LP stop pressure is the LP start pressure minus the differential.

Note:

The LP stop pressure must be above absolute vacuum (p_e = -1 bar)!

If with low stop pressure the refrigeration compressor will not stop, check to ensure that the differential value has not been set too high!

Pressure controls with automatic reset - HP:

Set the HP pressure on the "CUT-OUT" scale.

One rotation of the HP spindle ~ 2.3 bar.

Set the HP differential on the "DIFF" scale.

One rotation of the differential spindle ~ 0.3 bar.

The HP start pressure is the HP stop pressure minus the differential.

Start and stop pressures for both the LP and HP sides of the system should always be checked with an accurate pressure gauge.

Pressure controls with manual reset

Set the stop pressure on "CUT-OUT" scale (range scale).

Low pressure controls can be manually reset when the pressure is equal to the stop pressure plus the differential.

High pressure controls can be manually reset when the pressure is equal to the stop pressure minus the differential.

Dimensions and weights

<p><i>Flare connection</i></p> <p><i>KP 1, 2, 5, 6, 7B, 7S and 7W</i></p> <p><i>KP 15 and 17W</i></p>	<p><i>KP with top cover</i></p>
<p><i>M10 x 0.75 connection</i></p> <p><i>KP 1A, 2A and 5A</i></p> <p><i>KP 15A, 7AS and 7ABS</i></p>	<p><i>KP with IP 55 enclosure</i></p>
<p><i>Solder connection</i></p> <p><i>KP 1, 2, 5, 7B, 7S and 7W</i></p> <p><i>KP 15, 17W</i></p>	<p><i>KP with IP 55 enclosure</i></p> <p><i>IP 55 enclosure</i></p> <p><i>IP 55 enclosure</i></p>
<p><i>Weld nipple for KP-A</i></p>	<p><i>Weight</i></p> <p><i>KP 1, 2, 5 and 7: approx. 0.3 kg</i></p> <p><i>KP 15, 17 and 7BS: approx. 0.5 kg</i></p> <p><i>KP 1A and 5A: approx. 0.3 kg</i></p> <p><i>KP 15A and 7ABS: approx. 0.5 kg</i></p>

Danfoss can accept no responsibility for possible errors in catalogues, brochures and other printed material. Danfoss reserves the right to alter its products without notice. This also applies to products already on order provided that such alterations can be made without substantial changes being necessary in specifications already agreed. All trademarks in this material are property of the respective companies. Danfoss and the Danfoss logotype are trademarks of Danfoss A/S. All rights reserved.