

Data Sheet

Electric expansion valve

Type **AKV 10P** and **AKV 10PS**

For liquid injection into evaporators



AKV 10P and AKV10PS are electric operated expansion valves designed for refrigeration plants.

The AKV 10P and AKV 10PS valves are normally controlled by a controller from Danfoss range of ADAP- KOOL® controllers, that ensures a precise liquid injection into evaporators.

The AKV 10P and AKV 10PS valves are supplied as a part program, as follows:

- Separate valve
- Separate coil with terminal box, DIN plug or cable
- Spare parts in the form upper part, orifice and filter

The orifice and piston assemblies are replaceable. The AKV 10P and AKV 10PS valves cover a wide capacity range.

Features

Precise control of liquid injection

- Optimum utilization of the evaporator
- Increased energy efficiency and COP
- Improved overall system performance
- Enables energy saving minimum stable superheat and adaptive defrost algorithms due to turbulent flow
- Provides excellent distribution and oil return
- Repetitive operation of the valve at all conditions

Superior valve technology

- Soft pulse operation makes possible to have a low noise valve that guarantees precise flow control and increased energy efficiency of the system

Fully Serviceable valve

- Fast troubleshooting during system diagnostics
- Replaceable filter and orifice assembly
- Special Service coil available for installation and servicing

Fast opening/closing within sec.

- Quick reaction to the operating condition.
- Minimizes the risk of liquid refrigerant flowing into the compressor at shut down and low pressure cut out at start up
- Normally closed Solenoid tight shut-off valve
- Prevents migration of the refrigerant during stand-still
- Reduced complexity by reducing number of components in the system

Supports variety of refrigerants with wider regulation range

- Wide application scope
- High MOPD for use in R744 application

Compact, lightweight design

- Flexible and easy integration in any system

Wider selection range

- Wider range of AC and DC voltage coils
- Coils with various cable lengths

Valve construction

- Internal and external corrosion resistant

Protecting the environment and climate

- Manufactured according to ISO/TS16949
- Second – to – none quality and reliability

Portfolio overview





Related products

Table 1: Related products

AK-CC55 case controller	AK-CC 750 case controller	DML/DMSC Eliminator® hermetic filter drier
		

Standard coil for AKV 10P/ AKV 10PS

Table 2: Standard coil for AKV 10P/ AKV 10PS

Solenoid coil with terminal box	Solenoid coil with DIN spade and protection cap	Solenoid coil with cable	Solenoid coil with DIN spade
			

UL coil for AKV 10P / AKV 10PS

Table 3: UL coil for AKV 10P / AKV 10PS

Junction box NEMA 2	Conduit boss NEMA 4
	

Applications

Typical Application

Figure 1: Application

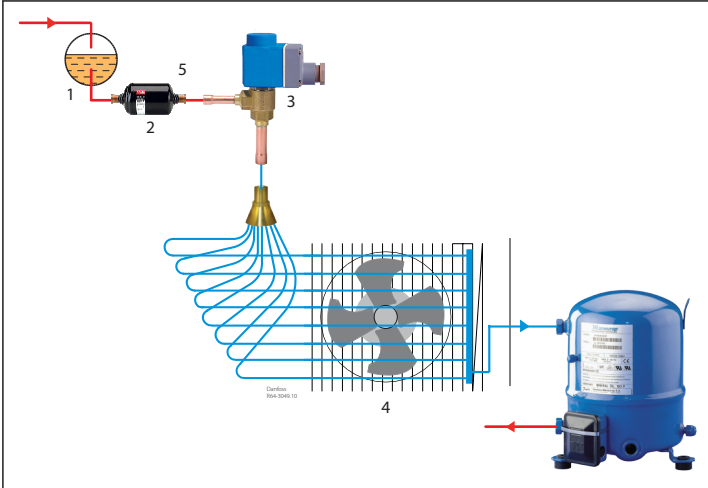

1	Receiver
2	Filter
3	AKV 10P / AKV 10PS
4	Evaporator
5	Max. 1 m/s

⚠ WARNING:

Filter < 40 micron micro is required for AKV 10 PS recommended filter drier, type DML / DMSC

Product specification

Technical data

Refrigerant

R1233zd, R1234yf, R1234ze, R1270, R134a, R22, R23, R290, R32, R404A, R407A, R407C, R407F, R407H, R410A, R422B, R422D, R438A, R444B, R448A, R449A, R449B, R450A, R452A, R452B, R454A, R454B, R454C, R455A, R463A, R469A, R507, R513A, R513B, R515A, R515B, R516A, R600, R600a, R744.

⚠ WARNING:

Safety notes for flammable refrigerants (R454C, R454A, R1234ze, R1270, R290, R32, R444B, R452B, R454B, R600, R600a, R455A, R516A, R1234yf):

- This product is validated in accordance to ATEX, EN 378, ISO 5149, ASHRAE 15, IEC 60335-2-x or equivalent standards.
- Ignition risk is evaluated in accordance to ISO 5149 and IEC 60335.
- See safety note below.

⚠ WARNING:

Safety notes:

- The product can be applied on systems with R454C, R454A, R1234ze, R1270, R290, R32, R444B, R452B, R454B, R600, R600a, R455A, R516A, R1234yf as the working fluid.
- For countries where safety standards are not an indispensable part of the safety system Danfoss recommend the installer to get a third party approval of the system containing flammable refrigerant.
- Note, please follow specific selection criteria stated in the datasheet for these particular refrigerants.
- The valve must only be used in closed circuit refrigeration system, where no oxygen is present acc. EN 378, ISO 5149 ASHRAE 15 or IEC 60335-2-x or equivalent standards.

Features	Direct operated valve	Servo operated valve
Valve type	AKV 10P0 to AKV 10P8	AKV 10PS4 to AKV 10PS8
Working principle	PWM (Pulse-width modulation)	PWM (Pulse-width modulation)
Recommended period of cycle time	6 Seconds	6 Seconds
Regulation range (Capacity range)	10 – 100%	10 – 100%
Connection type	Solder	Solder
Evaporating temperature (on outlet side of valve)	-60 – 60 °C / -76 – 140 °F	-60 – 60 °C / -76 – 140 °F
Ambient temperature (coil dependent)	-50 – 80 °C / -58 – 176 °F	-50 – 80 °C / -58 – 176 °F
Max. OPD	70 bar / 1015 psi (AKV 10P0 to AKV 10P2) ⁽¹⁾	N/A
Max. OPD	35 bar / 508 psi (AKV 10P3 to AKV 10P6) ⁽¹⁾	35 bar / 508 psi
Max. OPD	18 bar / 261 psi (AKV 10P7 to AKV 10P8) ⁽¹⁾	N/A
Min. OPD	0 bar / 0 psi	0.1 bar / 1.45 psi
Filter, replaceable	Internal 100 µm	Internal 53 µm
Max. working pressure	90 barg / 1305 psig	90 barg / 1305 psig
MAP (Max. Abnormal Pressure) 1305 psig	1305 psig	1305 psig
COT (Continuous Operation Temperature)	140 °F	140 °F
Recommended Danfoss filter	N/A	ELIMINATOR® Hermetic filter drier, type DML / DMSC

⁽¹⁾ Coil dependent (see page 15)

⚠ WARNING:

It is recommended to selected Servo operated AKV 10PS valves for those application where higher MOPD (with low coil power) and high dampening is required.

Technical data - Standard coils for AKV 10P / AKV 10PS

Table 4: Technical data

features	values
Design	In accordance with IEC 60335
Power supply	Alternating current (AC) and direct current (DC)
Permissible voltage variation	Alternating current (AC): 50 Hz and 60 Hz: -10% – 15% 50/60 Hz: ± 10% Direct current (DC): +/- 10%
Insulation of coil wire	Class H according to IEC 85
Connection	Terminal box, DIN spade or cable
Enclosure, IEC 60529	IP20, IP65 or IP67
Ambient temperature	-40 °C – 80 °C / -40 °F – 176 °F (coil dependent)

⚠ WARNING:

Safety notes for flammable refrigerants (R454C, R454A, R1234ze, R1270, R290, R32, R444B, R452B, R454B, R600, R600a, R455A, R516A, R1234yf):

1. The products (only refer to IP65/67 coils) are validated in accordance to ISO 5149, IEC 60335 (ref. IEC/EN 60079-15). Ignition risk is evaluated in accordance to ISO 5149 and IEC 60335 (ref. IEC/EN 60079-15). See safety note below.
2. Please make sure that there is no spark, arc during the application, especially the connection of coils.
3. Follow the instruction to mount the coil correctly and apply the O-ring for sealing, to prevent the moisture penetrate inside the coils.
4. Always install a fuse ahead of the coil to avoid short circuit (fuse size should be around 2 times of rated current, and time lag: medium);
5. The coil used in an area of not more than pollution degree 2.

⚠ WARNING:

Safety notes:

1. The product (only refer to IP65/67 coils) can be applied on systems with R454C, R454A, R1234ze, R1270, R290, R32, R444B, R452B, R454B, R600, R600a, R455A, R516A, R1234yf as the working fluid.
2. For countries where safety standards are not an indispensable part of the safety system Danfoss recommend the installer to get a third party approval of the system containing flammable refrigerant.
3. Note, please follow specific selection criteria stated in the datasheet for these particular refrigerants.
4. Note that the product (only refer to IP65/67 coils) has NOT been verified ATEX or IECEx or IEC 60079 series zone 2 compliant. This product is only validated for systems in compliance with ISO5149, IEC 60335 (ref. IEC/EN 60079-15). It is the responsibility of the user to verify such compliance. Improper use can cause explosion, fire, leakage potentially causing death, personal injury, or damage to property.

Technical data - UL coil for AKV 10P/AKV 10PS

Table 5: Technical data

features	values
Design	In accordance with UL 429
Power supply	Alternating current (AC)
Permissible voltage variation	Alternating current (AC): 50 Hz and 60 Hz: -10% – 15% 50/60 Hz: ± 10%
Insulation of coil wire	Class H according to IEC 85
Connection	Junction box or Conduit boss
Enclosure, IEC 60529	Junction box NEMA 2 ~ IP 12-32 Conduit boss NEMA 4 ~ IP 54
Ambient temperature	-40 °C – 50 °C / -40 °F – 122 °F

Valve identification (Examples of labels)

Table 6: Valve identification

Direct operated valve AKV 10P0 - AKV 10P8	Servo operated valve AKV 10PS4 - AKV 10PS8

A	Company logo
B	Type designation (0 = orifice size)
C	Code
D	Max. working pressure
E	Media temperature
F	Manufacturer address

Capacity

Direct operated valve AKV 10P - Rated capacity

Table 7: Direct operated valve AKV 10P

Valve type / orifice no.	R744 ⁽²⁾				R407A / R507 ⁽¹⁾		R404A ⁽¹⁾		k_v value	C_v value ⁽³⁾	Connection size Solder ODF/ODF		Code no. Single pack	Code no. Industrial pack 16 pcs. pr. Pack
	Refrig.	Freezing	Refrig.	Freezing	[kW]	[TR]	[kW]	[TR]			[in]	[mm]		
	[kW]	[kW]	[TR]	[TR]										
AKV 10P0	0.40	0.63	0.11	0.18	0.31	0.09	0.22	0.06	0.003	0.0035	3/8 × 1/2	–	068F5210	068F5230
AKV 10P0	0.40	0.63	0.11	0.18	0.31	0.09	0.22	0.06	0.003	0.0035	–	10 × 12	068F5200	068F5220
AKV 10P1	1.17	1.84	0.33	0.52	0.9	0.26	0.64	0.18	0.009	0.0104	3/8 × 1/2	–	068F5211	068F5231
AKV 10P1	1.17	1.84	0.33	0.52	0.9	0.26	0.64	0.18	0.009	0.0104	–	10 × 12	068F5201	068F5221
AKV 10P2	2.06	3.25	0.58	0.92	1.58	0.45	1.12	0.32	0.016	0.021	3/8 × 1/2	–	068F5212	068F5232
AKV 10P2	2.06	3.25	0.58	0.92	1.58	0.45	1.12	0.32	0.016	0.021	–	10 × 12	068F5202	068F5222
AKV 10P3	3.14	4.97	0.89	1.41	2.41	0.69	1.72	0.49	0.024	0.028	3/8 × 1/2	–	068F5213	068F5233
AKV 10P3	3.14	4.97	0.89	1.41	2.41	0.69	1.72	0.49	0.024	0.028	–	10 × 12	068F5203	068F5223
AKV 10P4	6.10	9.64	1.74	2.74	4.68	1.33	3.33	0.95	0.046	0.053	3/8 × 1/2	–	068F5214	068F5234
AKV 10P4	6.10	9.64	1.74	2.74	4.68	1.33	3.33	0.95	0.046	0.053	–	10 × 12	068F5204	068F5224
AKV 10P5	8.49	13.41	2.41	3.81	6.52	1.86	4.64	1.32	0.064	0.074	3/8 × 1/2	–	068F5215	068F5235
AKV 10P5	8.49	13.41	2.41	3.81	6.52	1.86	4.64	1.32	0.064	0.074	–	10 × 12	068F5205	068F5225
AKV 10P6	15.14	23.90	4.30	6.80	11.60	3.30	8.27	2.35	0.114	0.132	3/8 × 1/2	–	068F5216	068F5236
AKV 10P6	15.14	23.90	4.30	6.80	11.60	3.30	8.27	2.35	0.114	0.132	–	10 × 12	068F5206	068F5226
AKV 10P7	24.58	38.80	6.99	11.03	18.81	5.35	13.40	3.82	0.185	0.214	1/2 × 5/8	–	068F5217	–
AKV 10P7	24.58	38.80	6.99	11.03	18.81	5.35	13.40	3.82	0.185	0.214	–	12 × 16	068F5207	–
AKV 10P8	33.26	52.43	9.46	14.91	25.40	7.23	18.10	5.16	0.250	0.289	1/2 × 5/8	–	068F5218	–
AKV 10P8	33.26	52.43	9.46	14.91	25.40	7.23	18.10	5.16	0.250	0.289	–	12 × 16	068F5208	–

Electric expansion valve, type AKV 10P and AKV 10PS

- ⁽¹⁾ Rated capacities are based on:
 Condensing temperature $t_c = 38\text{ }^\circ\text{C} / 100\text{ }^\circ\text{F}$
 Liquid temperature $t_l = 37\text{ }^\circ\text{C} / 98\text{ }^\circ\text{F}$
 Evaporating temperature $t_e = 4\text{ }^\circ\text{C} / 39\text{ }^\circ\text{F}$
- ⁽²⁾ Rated capacities are based on:
 Condensing temperature $t_c = 0\text{ }^\circ\text{C} / 32\text{ }^\circ\text{F}$
 Evaporating temperature Refrig. $t_e = -10\text{ }^\circ\text{C} / 14\text{ }^\circ\text{F}$
 Evaporating temperature Freezing. $t_e = -30\text{ }^\circ\text{C} / -22\text{ }^\circ\text{F}$
 Subcooling = $1\text{ }^\circ\text{C} / 1.8\text{ }^\circ\text{F}$
- ⁽³⁾ Cv value is calculated from Kv value in above table

Servo operated valve AKV 10PS - Rated capacity

Table 8: Servo operated valve AKV 10PS

Valve type / orifice no.	R744 ⁽²⁾				R407A ⁽¹⁾		R404A/ R507 ⁽¹⁾		k _v value	C _v value ⁽³⁾	Connection size Solder ODF/ODF		Code no. Single pack	Code no. Industrial pack 16 pcs. pr. Pack
	Refrig.	Freezing	Refrig.	Freezing	[kW]	[TR]	[kW]	[TR]			[m ³ /h]	[gpm]		
	[kW]	[kW]	[TR]	[TR]	[kW]	[TR]	[kW]	[TR]	[m ³ /h]	[gpm]	[in]	[mm]		
AKV 10PS4	6.10	9.64	1.74	2.74	4.68	1.33	3.33	0.95	0.046	0.053	3/8 × 1/2	–	068F4044	068F5184
AKV 10PS4	6.10	9.64	1.74	2.74	4.68	1.34	3.33	0.88	0.046	0.053	–	10 × 12	068F4034	068F5174
AKV 10PS5	8.49	13.41	2.41	3.81	6.52	1.86	4.64	1.32	0.064	0.074	3/8 × 1/2	–	068F4045	068F5185
AKV 10PS5	8.49	13.41	2.41	3.81	6.52	1.86	4.64	1.32	0.064	0.074	–	10 × 12	068F4035	068F5175
AKV 10PS6	15.14	23.90	4.30	6.80	11.60	3.30	8.27	2.35	0.114	0.132	3/8 × 1/2	–	068F4046	068F5186
AKV 10PS6	15.14	23.90	4.30	6.80	11.60	3.30	8.27	2.35	0.114	0.132	–	10 × 12	068F4036	068F5176
AKV 10PS7	24.58	38.80	6.99	11.03	18.81	5.35	13.40	3.82	0.185	0.214	1/2 × 5/8	–	068F4047	–
AKV 10PS7	24.58	38.80	6.99	11.03	18.81	5.35	13.40	3.82	0.185	0.214	–	12 × 16	068F4037	–
AKV 10PS8	33.26	52.43	9.46	14.91	25.40	7.23	18.10	5.16	0.250	0.289	1/2 × 5/8	–	068F4048	–
AKV 10PS8	33.26	52.43	9.46	14.91	25.40	7.23	18.10	5.16	0.250	0.289	–	12 × 16	068F4039	–

- ⁽¹⁾ Rated capacities are based on:
 Condensing temperature $t_c = 38\text{ }^\circ\text{C} / 100\text{ }^\circ\text{F}$
 Liquid temperature $t_l = 37\text{ }^\circ\text{C} / 98\text{ }^\circ\text{F}$
 Evaporating temperature $t_e = 4\text{ }^\circ\text{C} / 39\text{ }^\circ\text{F}$
- ⁽²⁾ Rated capacities are based on:
 Condensing temperature $t_c = 0\text{ }^\circ\text{C} / 32\text{ }^\circ\text{F}$
 Evaporating temperature Refrig. $t_e = -10\text{ }^\circ\text{C} / 14\text{ }^\circ\text{F}$
 Evaporating temperature Freezing. $t_e = -30\text{ }^\circ\text{C} / -22\text{ }^\circ\text{F}$
 Subcooling = $1\text{ }^\circ\text{C} / 1.8\text{ }^\circ\text{F}$
- ⁽³⁾ Cv value is calculated from Kv value in above table

Flow direction

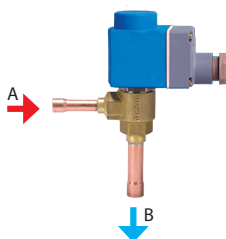

AKV 10P/10PS is designed for single flow direction and following pictures from A to B refers the normal flow.

Coolselector®2 - Valve sizing using calculation software



It is strongly recommended to use Coolselector®2 to find the correct valve for your application. The software can be downloaded from the Danfoss website. When using the calculation software it is recommended to choose a valve that is between 50% and 75% loaded at the nominal capacity. In addition, the liquid velocity in the line leading to the valve should not exceed 1m/s (3ft/s).

Download Coolselector®2 for free at coolselector.danfoss.com.

Coil Identification

Figure 2: Standard Coil

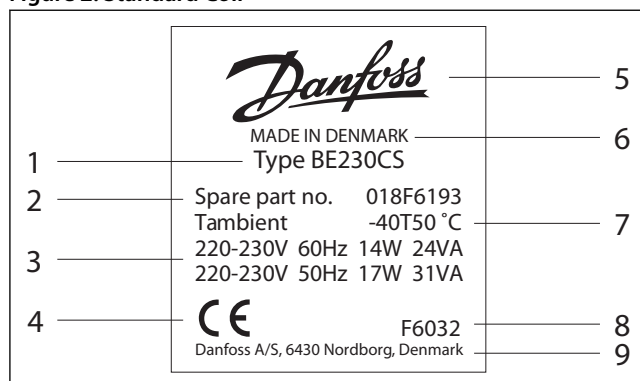

1	Type designation
2	Code no.
3	Voltage, frequency, Power consumption
4	Approvals
5	Company logo

6	Country of Origin
7	Ambient temperature
8	Production date
9	Manufacturer address

Figure 3: UL Coil

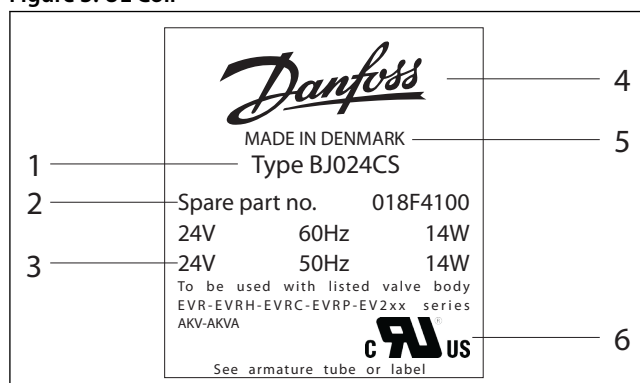

1	Type designation
2	Code no.
3	Voltage, frequency, Power consumption
4	Company logo
5	Country of Origin
6	Approvals

Design

Table 9: Design

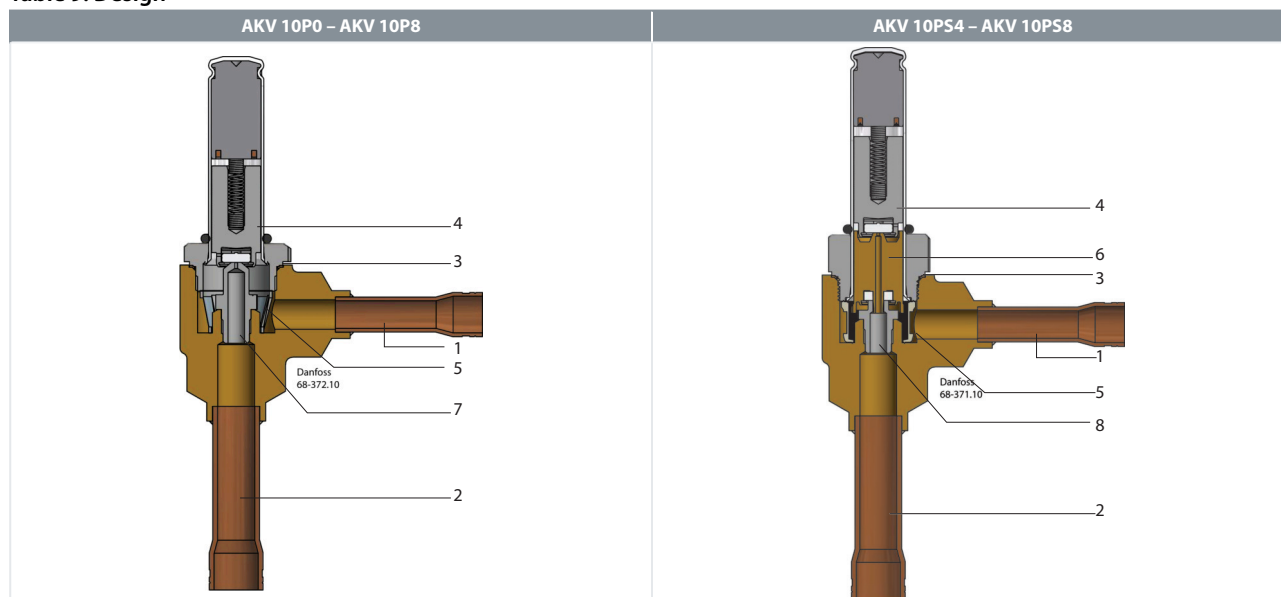

1	Inlet (connection)	6	Piston
2	Outlet (connection)	7	Orifice (AKV 10P)
3	Copper gasket	8	Orifice (AKV 10PS)
4	Amature		
5	Protection filter 100 micron (AKV 10P) and 53 micron (AKV 10PS)		

Material

1. Copper
2. Copper
3. Cu/Tn
4. Stainless steel
5. Nylon/stainless steel
6. Brass
7. Stainless steel
8. Stainless steel

The valve capacity is regulated by means of pulse-width modulation. Within a period of six seconds a voltage signal from the controller will be transmitted to and removed from the valve coil. This makes the valve open and close for the flow of refrigerant.

The relation between this opening and closing time indicates the actual capacity. If there is an intense need for refrigeration, the valve will remain open for almost all six seconds of the period. If the required amount of refrigeration is modest, the valve will only stay open during a fraction of the period.

The amount of refrigeration needed is determined by the controller. When no refrigeration is required, the valve will remain closed and thus function as a solenoid valve.

AKV 10P0 - AKV 10P8 is a direct operated valve which can operate at 0 bar/0 psi differential pressure.

AKV 10PS4 - AKV 10PS8 is a servo piston operated valve which needs a minimum differential pressure of 0.1 bar / 1.45 psi to open the valve and keep it open.

Dimensions and weight

Dimensions and weight AKV 10P valve

Table 10: AKV 10P0 - AKV 10P6 (Weight excluding coil: 0.30 kg / 0.66 lbs)

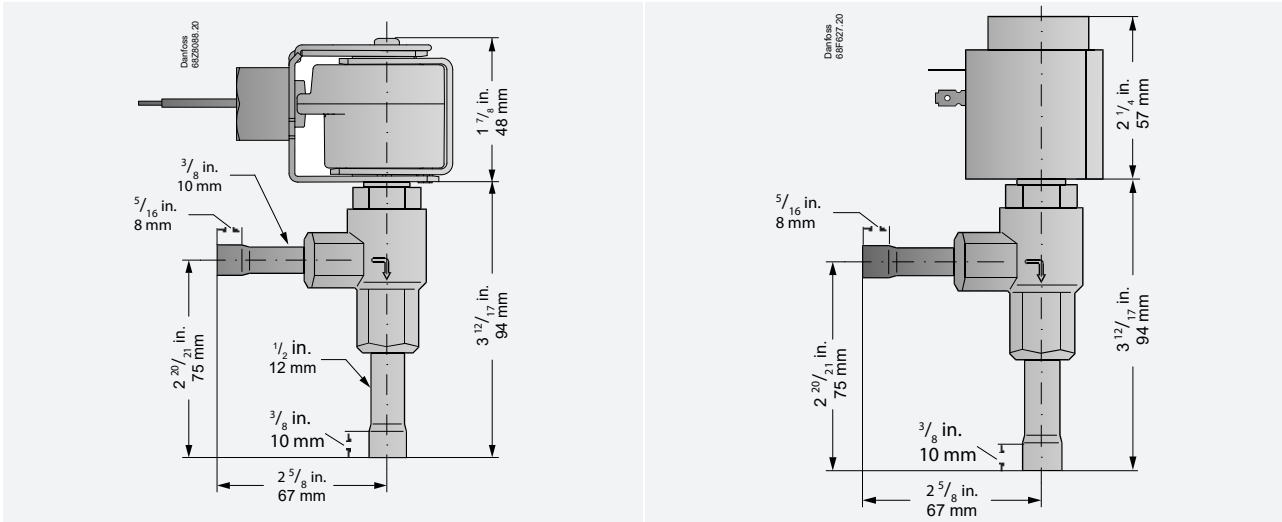
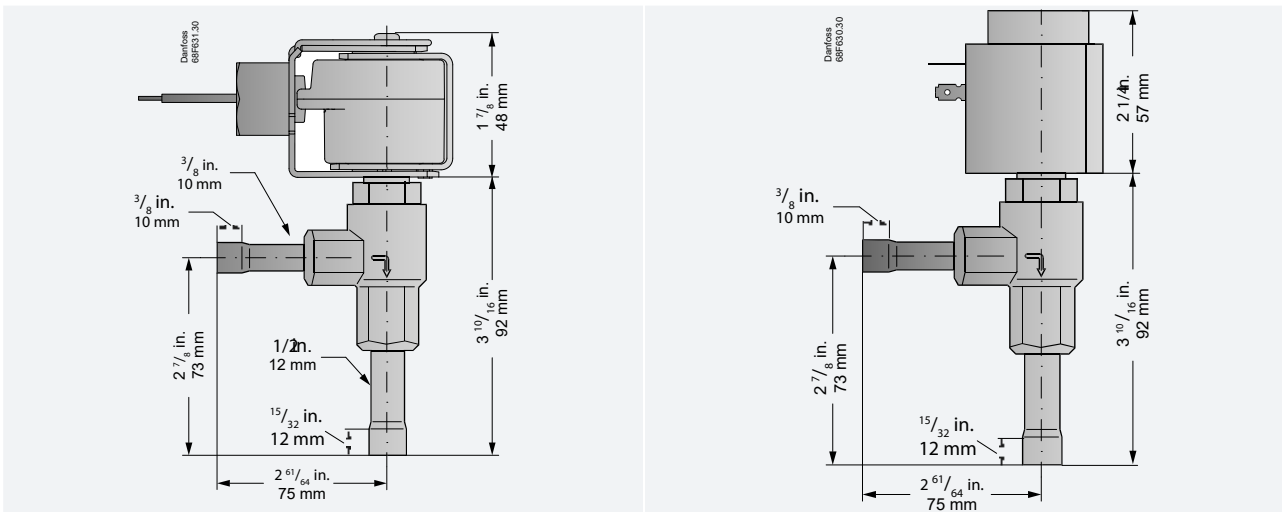

Table 11: AKV 10P7 - AKV 10P8 (Weight excluding coil: 0.343 Kg / 0.76 lbs)



Electric expansion valve, type AKV 10P and AKV 10PS

Dimensions and weight AKV 10PS valve

Table 12: AKV 10PS4 – AKV 10PS6 (Weight excluding coil: 0.335 Kg / 0.74 lbs)

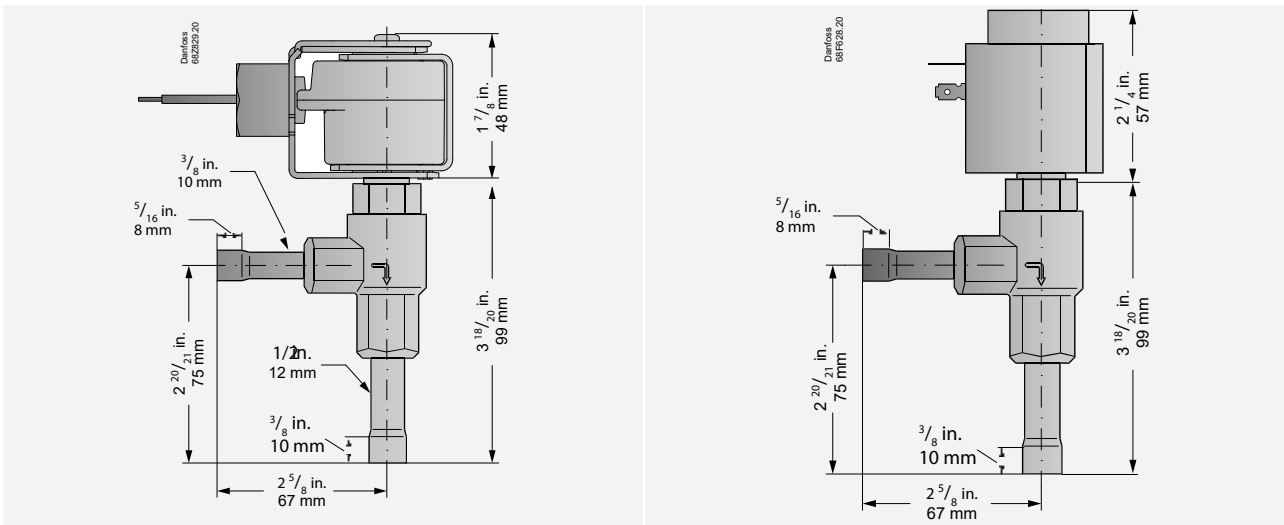
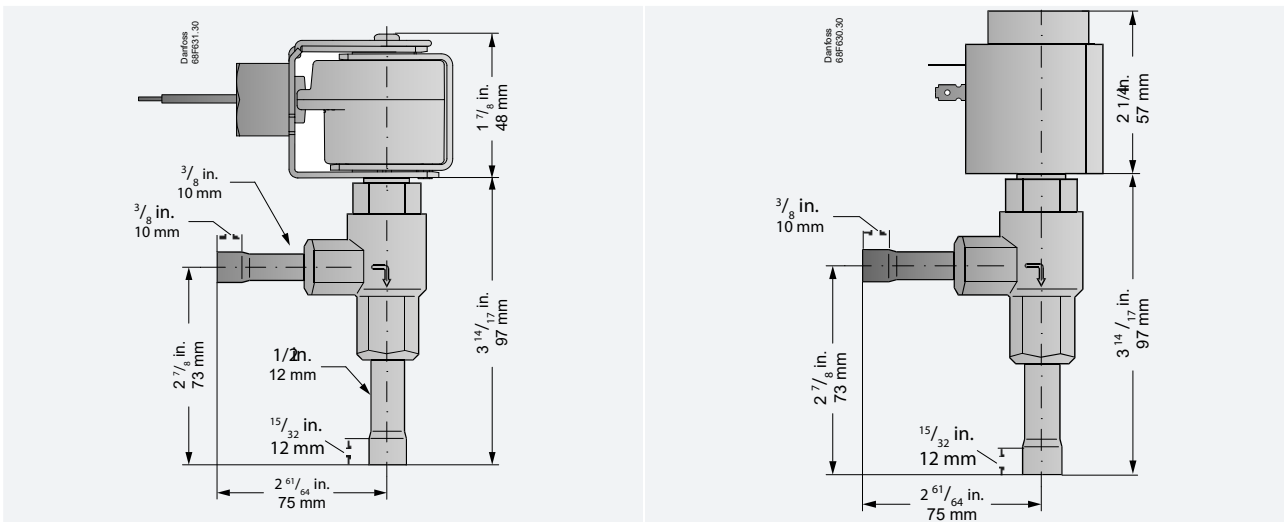

Table 13: AKV 10PS7 - AKV 10PS8 (Weight excluding coil: 0.343 Kg / 0.76 lbs)



Dimension and weight standard coils

Table 14: Dimension and weight standard coils

Terminal box 10 W Weight 0.29 Kg / 0.6 lbs	Cable 10 W Weight 0.29 Kg / 0.6 lbs
DIN socket 10 W Weight 0.24 Kg / 0.5 lbs	Terminal box 12 - 20 W Weight 0.55 Kg / 1.2 lbs

Dimensions and weight UL coils

Table 15: Dimensions and weight UL coils

Junction box Weight 0.860 lbs / 0.39 kg	Conduit boss Weight 0.717 lbs / 0.33 kg

Appendix: Dimensioning of the liquid line

Correctly dimensioned liquid line

To obtain a correct supply of liquid to the AKV 10P/PS valve, the liquid line to the individual AKV 10P/PS valve must be correctly dimensioned.

The liquid flow rate should not exceed 1 m/s (3 ft/s).

Dimensioning of the liquid line must be based on the capacity of the valve at the pressure drop with which it is operating and not on the evaporator's capacity.

Electric expansion valve, type AKV 10P and AKV 10PS

Table 16: CO₂

Type	Pipe dimension	
	Refrigeration	Freezing
AKV 10P0	3/8 in / 10 mm	3/8 in / 10 mm
AKV 10P1	3/8 in / 10 mm	3/8 in / 10 mm
AKV 10P2	3/8 in / 10 mm	3/8 in / 10 mm
AKV 10P3	3/8 in / 10 mm	3/8 in / 10 mm
AKV 10P4	3/8 in / 10 mm	3/8 in / 10 mm
AKV 10P5	3/8 in / 10 mm	1/2 in / 12 mm
AKV 10P6	1/2 in / 12 mm	5/8 in / 15 mm
AKV 10P7	5/8 in / 15 mm	3/4 in / 18 mm
AKV 10P8	5/8 in / 15 mm	3/4 in / 18 mm

Table 17: R407A

Type	Pipe dimension	
	Refrigeration	Freezing
AKV 10P0	3/8 in / 10 mm	3/8 in / 10 mm
AKV 10P1	3/8 in / 10 mm	3/8 in / 10 mm
AKV 10P2	3/8 in / 10 mm	3/8 in / 10 mm
AKV 10P3	3/8 in / 10 mm	3/8 in / 10 mm
AKV 10P4	3/8 in / 10 mm	3/8 in / 10 mm
AKV 10P5	1/2 in / 12 mm	1/2 in / 12 mm
AKV 10P6	1/2 in / 15 mm	1/2 in / 15 mm
AKV 10P7	5/8 in / 16 mm	5/8 in / 16 mm

NOTE:

The conditions are the same as for the rated capacities.

Evaporating temperature is -10 °C for refrigeration and -30 °C for freezing.

The super heat is 8 K for both refrigeration and freezing.

Pipes are according ANSI or DIN-EN.

If conditions deviate from above, the pipe dimensions should be checked.

Troubleshooting

Table 18: Troubleshooting

Symptom	Possible Cause	Remedy	
Valve does not open	Lack of proper electrical connection/Power	Check the connection between valve and a controller	
	Incorrect voltage/frequency	Check coil specification against measured operating voltage	
	Differential pressure too high/low	Check differential pressure of valve against technical specification	
	Impurities in the valve	Replace with suitable valve and or coil	
	Burnt out coil		Check dirt inside valve and clean out impurities
			Never take the coil off the valve if voltage is applied.
			The coil can burn out
	Check the wiring diagram and wiring itself		
	Check relay contacts, lead connections and fuses		
	Valve stuck open after being assembled	Check Instruction if all correct parts are used, and correctly assembled	
	Valve does not open after orifice has been exchanged to a larger capacity due to high differential pressure	Replace with suitable valve and or coil	
Internal leakage/ valve does not close or closes partially	Continuous voltage on coil	Do not remove powered coil off the valve	
	Impurities in the valve	Check dirt inside valve and clean out impurities	
	Pulsation in discharge line Differential pressure too high in open position		Check pressure and flow conditions
			Check the supply voltage in the coil
		Replace with suitable valve	

Electric expansion valve, type AKV 10P and AKV 10PS

Symptom	Possible Cause	Remedy	
Insufficient capacity	Valve capacity too small	Check refrigeration system capacity and compare with valve capacity Replace with larger valve if necessary - larger capacity orifice in AKV 10P - larger capacity piston in AKV 10PS	
	Suction pressure too low Evaporator superheat too high	Check superheat performance, the settings SH min and SH max. in the super heat controller Check valve capacity Check coil excitation time Also check section "High Superheat"	
	Valve blocked with foreign material	Valve strainer blocked, replace strainer with a new one	
	Evaporator fully or partly iced up	Valve blocked with foreign material Also check "Insufficient capacity"	Replace valve strainer/filter De-ice evaporator
	High superheat	Lack of sub-cooling Controller is not setup/tuned properly	Check refrigerant Also refer to section Insufficient capacity Check the controller superheat settings and sensors connected to it Tune PID parameters in the controller
Flash gas	Lack of sub-cooling ahead of valve	Check refrigerant for flash gas ahead of valve/external subcooler If the valve is placed much higher than condenser outlet Check pressure difference	
	Oversized valve selected	Limit max opening degree of the valve setting in controller Check refrigeration system capacity and compare with valve capacity Use proper valve size suitable for the system	
Pulsations in liquid line	High flow velocity, max. 1 m/s	Check flow velocity, using coolselector2 Change to AKV 10PS for maximum dampening effect Use larger diameter pipes to reduce flow velocity	
Overheating coil	Armature is not moving when coil is energized Too high voltage supply, dirt in valve, too high MOPD)	Check section valve does not open	

Ordering

Standard global coils

Table 19: Coil for high MOPD performance

Multi-pack code no.	Identical Industrial pack code no.		Identical spare part coil with DIN spade	Supply voltage/power/frequency	Connection type/enclosure rating	MOPD of individual coil (bar)						
						AKV 10P						AKV 10PS
	Orifice size						Orifice size					
	Code no.	Pcs. per pack				0 to 2	3	4	5	6	7 to 8	PS4 to PS8
018F6905	-	-	-	230 V AC 19 W, 50 Hz	With terminal box, IP67	70	55	40	55	N/A	N/A	N/A

⚠ WARNING:

N/A: Danfoss recommends using servo operated valves AKV 10PS to achieve higher MOPD.

Table 20: Standard global coils

Multi-pack code no.	Identical Industrial pack code no.		Identical spare part coil with DIN spade	Supply voltage/power/frequency	Connection type/enclosure rating	MOPD of individual coil (bar)						
						AKV 10P						AKV 10PS
	Orifice size						Orifice size					
	Code no.	Pcs. per pack				0 to 3	4	5	6	7 to 8	PS4 to PS8	
DC coils - with/without terminal box												
018F6780	-	-	-	100 V DC 18 W	With terminal box, IP 67	33	22	35	35	18	29	
018F6860	-	-	-	110V DC 16 W	With terminal box, IP 67	35	32	35	35	18	35	
018F6851	-	-	-	220V DC 20 W	With terminal box, IP 67	35	34	35	35	18	35	
018F6781	018F8781	25	018F6991	230 V DC 18 W	With terminal box, IP 67	26	16	35	35	18	22	
AC coils - with cable												
018F4961	018F8291	6	Not relevant	230 V AC 16 W, 50 Hz	With 8 m cable, IP 67	35	25	25	25	14	35	
018F6264	-	-	Not relevant	220 V AC 14 W, 60 Hz	With 1 m cable, IP 67	25	N/A	18	N/A	N/A	25	
018F6282	018F8232	24	Not relevant	220-230 V AC 16 W, 50 Hz	With 1 m cable, IP 67	35	25	25	25	14	35	
-	018F8290	12	Not relevant	220-230 V AC 17 W, 50 Hz	With 3 m cable, IP 67	35	25	25	25	14	35	
AC coils - with/without terminal box												
018F6807	-	-	-	24 V AC 11 W, 50 Hz	With terminal box, IP 67	22	14	19	13	9	22	
018F6904	-	-	-	24 V AC 24 W, 50 Hz	With terminal box, IP 67	35	35	35	30	18	35	
018F6815	-	-	-	24 V AC 15 W, 60 Hz	With terminal box, IP 67	26	16	22	15	10	24	
018F6906	018F8906	24	-	24 V AC 22 W, 60 Hz	With terminal box, IP 67	35	26	34	22	15	35	
018F6813	-	-	-	110 V AC 16 W, 60 Hz	With terminal box, IP 67	35	18	30	18	14	35	
018F6701	018F8701	50	018F6176	230 V AC 12 W, 50 Hz	With terminal box, IP 67	25	N/A	18	N/A	N/A	25	
018F6801	018F8801	24	-	220 V AC 15 W, 50 Hz	With terminal box, IP 67	35	25	25	N/A	N/A	25	
018F6732	018F8732	50	018F6193	230 V AC 17 W, 50 Hz	With terminal box, IP 67	35	25	25	25	14	35	
018F6713	-	-	-	240 V AC 15 W, 60 Hz	With terminal box, IP 67	25	18	25	18	N/A	30	
018F6814	-	-	-	230 V AC 16 W, 60 Hz	With terminal box, IP 67	35	25	35	18	14	35	

Electric expansion valve, type AKV 10P and AKV 10PS

⚠ WARNING:

1. N/A: Coil is not suitable due to too low MOPD.
2. Multi-pack and spare part coil code nos. can be ordered as single parts.
3. MOPD table is based on:
 - Nominal voltage
 - Max media temperature 60 °C (140 °F)
 - Max ambient temperature 50 °C (122 °F)

BJ and BX Coils (UL coils)

Table 21: AC coils - Junction box NEMA 2 (type BJ)

Multi-pack code no.	Supply voltage/ power/ frequency	Wire length		MOPD of individual coil (bar)					
				AKV 10P					AKV 10PS
		Orifice size					Orifice size		
(in)	(cm)	0 to 3	4	5	6	7 to 8	PS4 to PS8		
018F4100	24 V AC 14 W, 60 Hz	7	18	25	18	25	14	N/A	25
	24 V AC 14 W, 50 Hz	7	18	35	25	35	25	18	35
018F4110	110 V AC 16 W, 60 Hz	7	18	25	18	25	18	N/A	30
	120 V AC 15 W, 60 Hz	7	18	35	30	35	25	18	35
018F4120	208 V AC 14 W, 60 Hz	7	18	18	14	18	14	N/A	25
	240 V AC 14 W, 60 Hz	7	18	35	25	35	18	14	35
	230 V AC 17 W, 50 Hz	7	18	35	30	35	30	18	35
018F4130	120 V AC 16 W, 60 Hz	7	18	35	30	35	25	14	35
018F4132	208 V AC 16 W, 60 Hz	7	18	35	30	35	25	14	35
018F4134	240 V AC 16 W, 60 Hz	7	18	35	30	35	25	14	35

Table 22: AC coils - Conduit boss NEMA 4 (type BX)

Multi-pack code no.	Supply voltage/ power/ frequency	Wire length		MOPD of individual coil (bar)					
				AKV 10P					AKV 10PS
		Orifice size					Orifice size		
(in)	(cm)	0 to 3	4	5	6	7 to 8	PS4 to PS7		
018F4102	24 V AC 14 W, 60 Hz	18	46	25	18	25	14	N/A	25
	24 V AC 14 W, 50 Hz	18	46	35	25	35	25	18	35
018F4103	24 V AC 14 W, 60 Hz	71	180	25	18	25	14	N/A	25
	24 V AC 14 W, 50 Hz	71	180	35	25	35	25	18	35
018F4104	24 V AC 14 W, 60 Hz	98	250	25	18	25	14	N/A	25
	24 V AC 14 W, 50 Hz	98	250	35	25	35	25	18	35
018F4112	110 V AC 16 W, 60 Hz	18	46	25	18	25	18	N/A	30
	110 V AC 16 W, 50 Hz	18	46	35	30	35	25	18	35
	120 V AC 15 W, 60 Hz	18	46	35	18	35	18	14	35
018F4113	110 V AC 16 W, 60 Hz	36	91	25	18	25	18	N/A	30
	110 V AC 16 W, 50 Hz	36	91	35	30	35	25	18	35
	120 V AC 15 W, 60 Hz	36	91	35	18	35	18	14	35
018F4114	110 V AC 16 W, 60 Hz	71	180	25	18	25	18	N/A	30
	110 V AC 16 W, 50 Hz	71	180	35	30	35	25	18	35
	120 V AC 15 W, 60 Hz	71	180	35	18	35	18	14	35
018F4115	110 V AC 16 W, 60 Hz	98	250	25	18	25	18	N/A	30
	110 V AC 16 W, 50 Hz	98	250	35	30	35	25	18	35
	120 V AC 15 W, 60 Hz	98	250	35	18	35	18	14	35
018F4122	208 V AC 14 W, 60 Hz	18	46	18	14	18	14	N/A	25
	240 V AC 14 W, 60 Hz	18	46	35	25	35	18	14	35
	230 V AC 17 W, 50 Hz	18	46	35	30	35	30	18	35
018F4123	208 V AC 14 W, 60 Hz	98	250	18	14	18	14	N/A	25
	240 V AC 14 W, 60 Hz	98	250	35	25	35	18	14	35
	230 V AC 17 W, 50 Hz	98	250	35	30	35	30	18	35
018F4131	120 V AC 16 W, 60 Hz	98	250	35	30	35	25	14	35
018F4133	208 V AC 16 W, 60 Hz	98	250	35	30	35	25	14	35
018F4135	240 V AC 16 W, 60 Hz	98	250	35	30	35	25	14	35

Electric expansion valve, type AKV 10P and AKV 10PS

⚠ WARNING:

1. N/A: Coil is not suitable due to too low MOPD.
2. Multi-pack coil code nos. can be ordered as single parts.
3. MOPD table is based on:
 - Nominal voltage
 - Max media temperature 60 °C (140 °F)
 - Max ambient temperature 50 °C (122 °F)

Spareparts

For Direct operated AKV 10P

AKV 10P0 – AKV 10P3 Orifice kit 1	AKV 10P4 – AKV 10P8 Orifice kit 2	AKV 10P0 – AKV 10P8 Armature kit 3*	AKV 10P0 – AKV 10P8 Filter kit 4
Code no. 068F5151	Code no. 068F5152	Code no. 068F5153	Code no. 068F5154

*Retrofit kit for converting
AKV 10-1 - AKV 10-7, AKVH 10-0 - AKVH 10-6
and AKV 10PS4 - AKV 10PS8
to AKV 10P0 - AKV 10P8

For servo operated AKV 10PS

AKV 10PS4 - AKV 10PS8 Orifice kit 5	AKV 10PS4 - AKV 10PS8 Filter Kit 6	AKV 10PS4 - AKV 10PS8 Armature kit 7*
Code no. 068F5155	Code no. 068F5156	Code no. 068F5161

*Retrofit kit for converting

Electric expansion valve, type AKV 10P and AKV 10PS

AKV 10-1 -AKV 10-7, AKVH 10-0 - AKVH 10-6
and AKV 10P0 - AKV 10P8
to AKV 10PS4 - AKV 10PS8

Accessories

Figure 4: Plug for DIN
spade connection

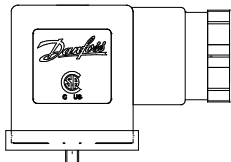

Type	Voltage	Frequency	Quantity	Code no. Multi pack
	[V]	[Hz]	[Pcs]	
DIN plug	Max. 250	50 / 60	100	042N1256

Single pack = 1 product in a box with installation guide

Multi pack = box with x pieces single pack (can be split)

Industrial pack = x pieces in one box (cannot be split)



Product	Description	Code no.
Solenoid valve Tester	Permanent magnet for AKV 10P and AKV 10PS (for installation and testing purpose)	018F0091

Certificates, declarations, and approvals

The list contains all certificates, declarations, and approvals for this product type. Individual code number may have some or all of these approvals, and certain local approvals may not appear on the list.

Some approvals may change over time. You can check the most current status at danfoss.com or contact your local Danfoss representative if you have any questions.

Valid approvals



(Refrigerant valve) 53RO

Low Voltage Directive (LVD) 2014/35/EU

Table 23: Approvals for AKV 10P and 10PS

File name	Document type	Document topic	Approval authority
033F1035.AJ	Manufacturers Declaration	PED	Danfoss

Online support

Danfoss offers a wide range of support along with our products, including digital product information, software, mobile apps, and expert guidance. See the possibilities below.

The Danfoss Product Store



The Danfoss Product Store is your one-stop shop for everything product related—no matter where you are in the world or what area of the cooling industry you work in. Get quick access to essential information like product specs, code numbers, technical documentation, certifications, accessories, and more.

Start browsing at store.danfoss.com.

Find technical documentation



Find the technical documentation you need to get your project up and running. Get direct access to our official collection of data sheets, certificates and declarations, manuals and guides, 3D models and drawings, case stories, brochures, and much more.

Start searching now at www.danfoss.com/en/service-and-support/documentation.

Danfoss Learning



Danfoss Learning is a free online learning platform. It features courses and materials specifically designed to help engineers, installers, service technicians, and wholesalers better understand the products, applications, industry topics, and trends that will help you do your job better.

Create your Danfoss Learning account for free at www.danfoss.com/en/service-and-support/learning.

Get local information and support



Local Danfoss websites are the main sources for help and information about our company and products. Find product availability, get the latest regional news, or connect with a nearby expert—all in your own language.

Find your local Danfoss website here: www.danfoss.com/en/choose-region.

Coolselector®2 - find the best components for you HVAC/R system



Coolselector®2 makes it easy for engineers, consultants, and designers to find and order the best components for refrigeration and air conditioning systems. Run calculations based on your operating conditions and then choose the best setup for your system design.

Download Coolselector®2 for free at coolselector.danfoss.com.

Danfoss A/S

Climate Solutions • danfoss.com • +45 7488 2222

Any information, including, but not limited to information on selection of product, its application or use, product design, weight, dimensions, capacity or any other technical data in product manuals, catalogues descriptions, advertisements, etc. and whether made available in writing, orally, electronically, online or via download, shall be considered informative, and is only binding if and to the extent, explicit reference is made in a quotation or order confirmation. Danfoss cannot accept any responsibility for possible errors in catalogues, brochures, videos and other material. Danfoss reserves the right to alter its products without notice. This also applies to products ordered but not delivered provided that such alterations can be made without changes to form, fit or function of the product.

All trademarks in this material are property of Danfoss A/S or Danfoss group companies. Danfoss and the Danfoss logo are trademarks of Danfoss A/S. All rights reserved.