



Silent+ Mini White

CONDENSATE REMOVAL PUMP

Incredibly quiet, easy to install and maintain, the Silent+ Mini White has been designed to fit either side of the evaporator unit. A double insulated reservoir eliminates condensation and is simple to unclip for cleaning and maintenance.



45L/h max. flow



10m max. rec. head
(flow rate 23L/h)



As low as 16dB(A)
when operating

KEY FEATURES

- Ultra quiet operation
- Extra quick to fit
- Compact & discreet
- Removable reservoir

SUITABILITY

- Up to 16kW / 54,000Btu/h
- High wall mini split systems
- ✓ **Perfect for...** domestic environments where minimising audible noise is crucially important

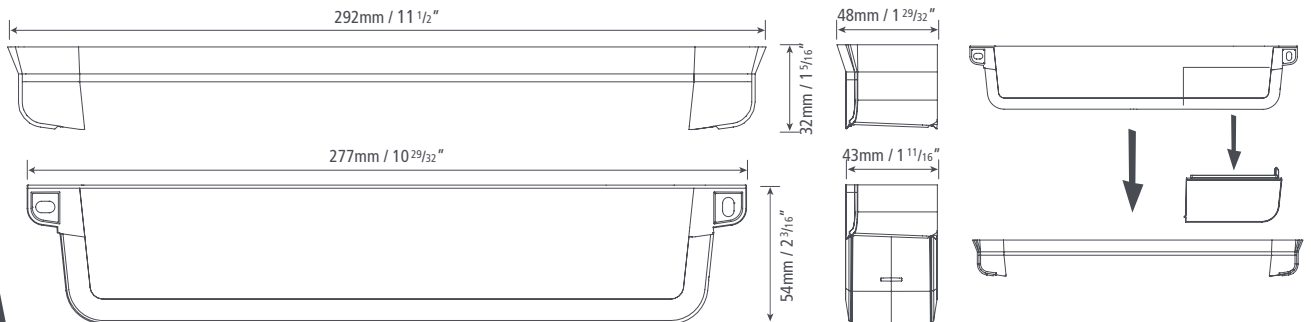

SILENT+ MINI WHITE @ 230 VAC 50Hz

Max. flow	45L/h @ 0m head
Max. rec. head	10m
Min. dB(A) @ 1m	16
Power supply	230 VAC, 0.18A, 2.1W 50/60Hz
Rated	Continuous
Class	II appliance <input type="checkbox"/>
Max. unit output	16kW / 54,000Btu/h
Max. ambient temperature	40°C / 104°F
IP Protection	IP24
Inlet o/d	16mm (5/8") – 26mm (1")
Outlet o/d	Ø6mm / 1/4"
Safety switch	5.0 A NO & NC contacts
Thermal protection	✓
Self priming	✓

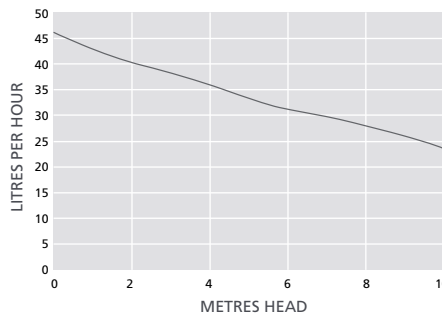

IN THE BOX

- Silent+ Mini White pump (incl. hard wired 1m power cable)
- Fitting template
- Outlet elbow
- Screw caps
- Spacer
- Installation manual

Download manual at aspenspumps.com

SILENT+ MINI WHITE OPTIONS

- Silent+ Mini White (Europe) FP3450

SUGGESTED XTRA ACCESSORIES

Description	Part No.
1 Amp Fuse	FP2620
Tube To Soil Stack Adaptor	FP2038

For more installation accessories take a look at our Aspen Xtra range

Ensure ALL cleaning chemicals are flushed out of the reservoir after use.

Information correct at time of going to press.