

# BRACED CANTILEVER BRACKETS

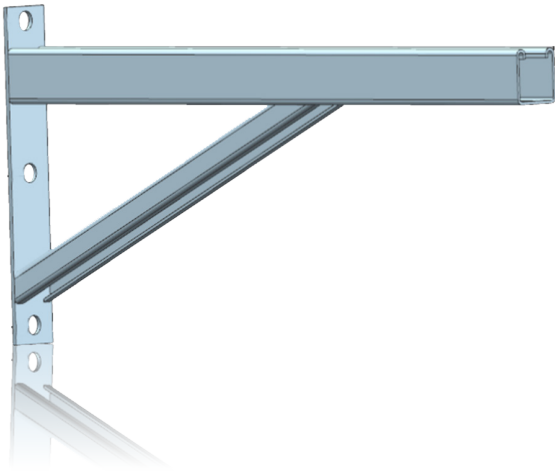

Freddox cantilever brackets offer value, convenience, and confidence when installing Refrigeration and Air Conditioning condensing units. Freddox cantilever brackets are designed and manufactured to meet the stringent requirements of the HVAC&R industry.

Available in a range of lengths to provide a solution for condensing unit installations.

Freddox cantilever brackets come with all fixings and fasteners required for installation and are fully galvanised after fabrication to provide heavy duty protection in most conditions.



# TECHNICAL DATA

PROPERTY	SPECIFICATION
Material	Mild Steel
Finish	H.D.GALV
Standards	Hot Dipped Galvanised to AS/NZS 4680:2006 Manufactured from Material to meet AS1594:2002

## Dimensions (mm)

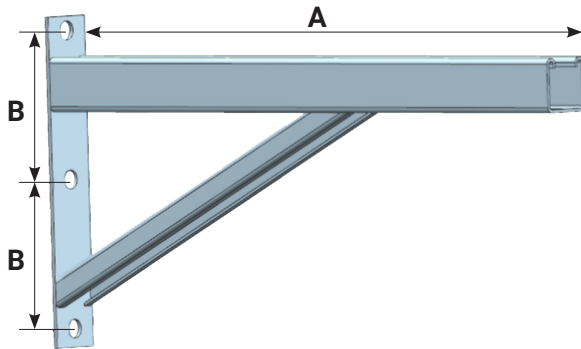

ITEM NUMBER	A (mm)	B (mm)	HOLE DIAMETER (mm)	UDL (kg)	MID POINT (kg)	END POINT (kg)
CANTILEVER-500	500	126	14	365	315	185
CANTILEVER-650	650			315	275	165
CANTILEVER-800	800			300	260	155

Note: Standard brackets includes 6 x 12mm dyna bolts. All brackets come with 4 x rubber anti vibration foot mounts and 2 x end caps.

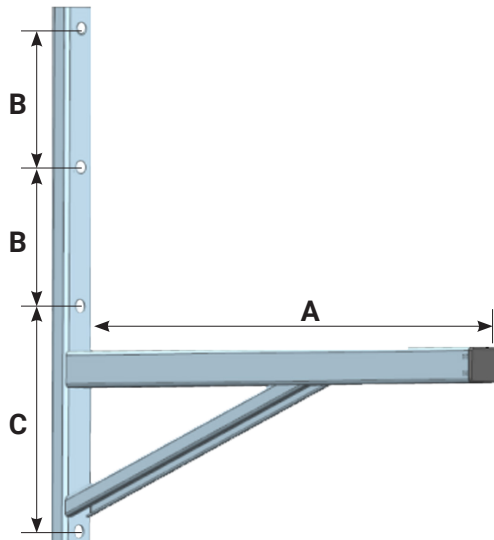

ITEM NUMBER	A (mm)	B (mm)	C (mm)	HOLE DIAMETER (mm)	UDL (kg)	MID POINT (kg)	END POINT (kg)
CANTILEVER-500SP	500	155	245	14	385	325	200
CANTILEVER-650SP	650				325	295	190
CANTILEVER-800SP	800				315	280	170

Note: Heavy duty brackets include 8 x dyna bolts. All brackets come with 4 x rubber anti vibration foot mounts and 2 x end caps.

FREDDOXCANTILEVERBRACKET\_0224