

# INT69<sup>®</sup> Motor protector

INT69<sup>®</sup>



INT69

## Application

Motor protection based on PTC sensors is one of the most effective and reliable protective measures against thermal overload in electrical machines. The protection unit is composed of the INT69 motor protector and the PTC sensors. Due to its compact construction, the INT69 is suitable for installation in electrical devices or in the terminal boxes of electrical machines.

## Functional description

At the measuring circuit input of the INT69, it is possible to connect up to nine DIN 44081, DIN 44082 conform PTC sensors. Sensors with different nominal response temperatures may be used. Thus it is possible to monitor several measuring points with only one INT69 motor protector.

If the temperature in one of the monitored parts or sections reaches the nominal response temperature of the respective PTC sensor, the sensor becomes highly resistive and the motor protector switches off.

The device switches itself on again after cooling back down.

The relay's switching output is a potential-free changeover contact.

This circuit works in accordance with the closed-circuit principle, i.e. even in the event of a sensor or cable break, the relay returns to its rest position and switches off.

The sensor, relay and supply current circuits are galvanically isolated from each other.



The mounting, maintenance and operation are to be carried out by an electrician. The valid European and national standards for connecting electrical equipment and cooling installations have to be observed. Connected sensors and connection lines that extend from the terminal box have to feature at least a basic insulation.

See back side for further specifications

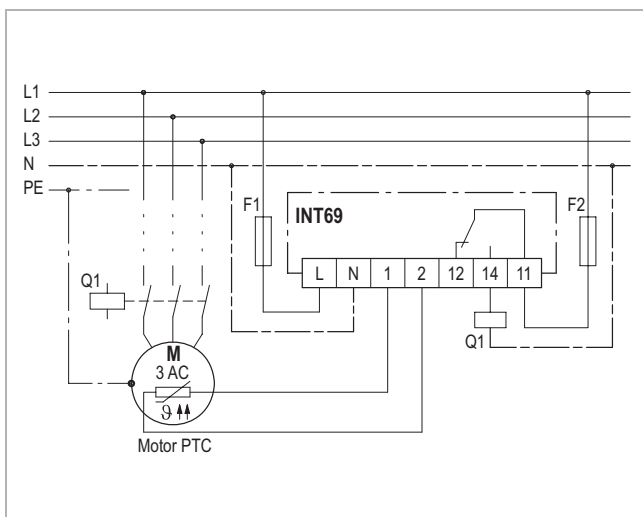

Wiring diagram

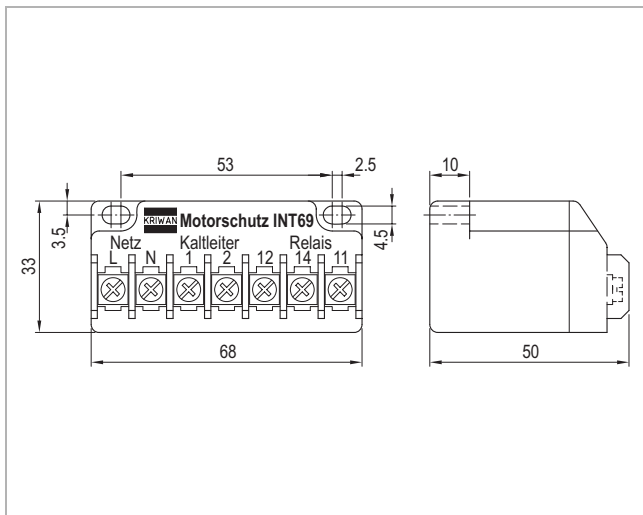

Dimensions in mm

Technical changes reserved



**INT69®**

# INT69® Motor protector

## Technical specifications

Supply voltage	
- 22 A 460	AC 50/60Hz 115/120V-230/240V ±10% 3VA
- 31 A 460	AC 50/60Hz 24V ±10% 3VA
Permitted ambient temperature	-30...+70°C
Temperature measuring circuits	
- Type	1-9 PTC sensors acc. to DIN 44081, DIN 44082 in series
- $R_{25, total}$	<1.8k $\Omega$
- $R_{trip}$	4.5k $\Omega$ ±20%
- $R_{reset}$	2.75k $\Omega$ ±20%
- Max. length connection line	30m
Relay	
- Contact (22 A 460)	AC 240V 2.5A C300 at least AC/DC 24V 20mA
- Contact (31 A 460)	AC 240V 2.5A C300 at least AC/DC 100mV 0.5mA
- Mechanical service life	Approx. 1 million switching cycles
Protection class acc. to EN 60529	IP20
Connection type	Screw type terminal
Housing material	PA glass-fibre-reinforced
Mounting	Screw mounted
Dimensions	Refer to dimensions in mm
Weight	Approx. 200g
Check base	EN 61000-6-2, EN 61000-6-3 EN 61010-1 Overvoltage category II Pollution level 2
Approval	UL File No. E75899 cURus

## Order data

INT69 Motor protector (AC 115/120V-230/240V)	<b>22 A 460</b>
INT69 Motor protector (AC 24V)	<b>31 A 460</b>
Accessories and application information	see <a href="http://www.kriwan.com">www.kriwan.com</a>