

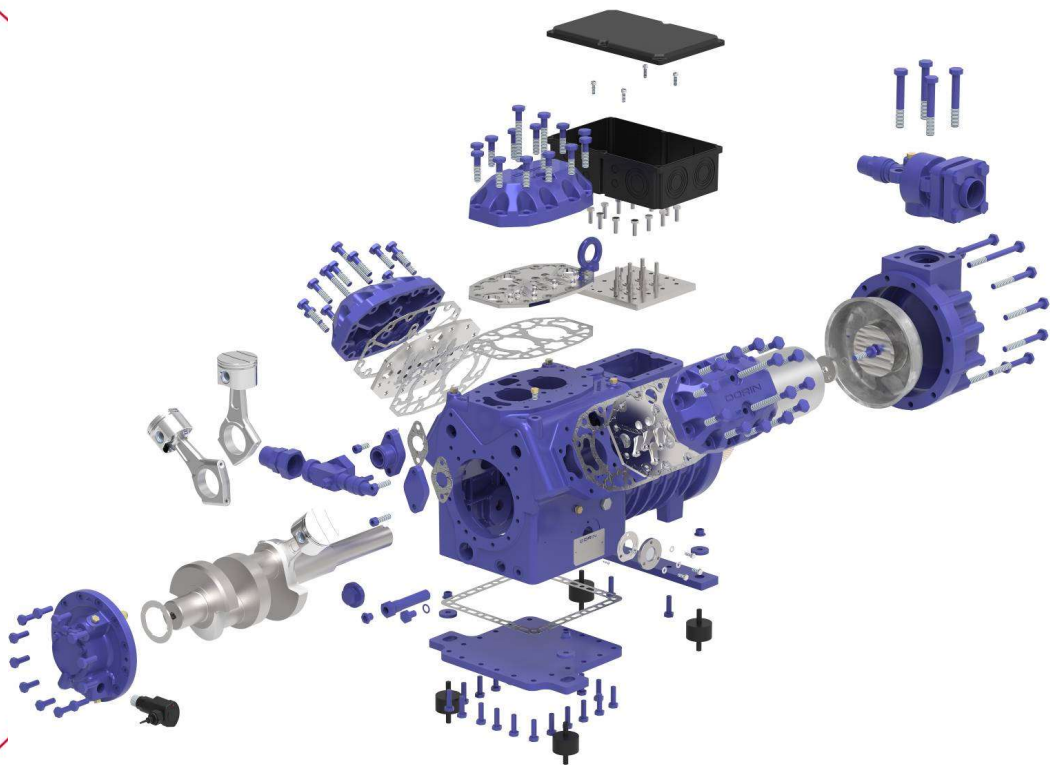

OFFICINE MARIO DORIN SINCE 1918
DORIN[®]
INNOVATION

COPPIA DI SERRAGGIO TIGHTENING TORQUE



BOLLETTINO TECNICO
TECHNICAL BULLETIN

INDICE

GENERALITA'.....PAG 3
PASSANTI ELETTRICI.....PAG 4
TABELLE COPPIE DI SERRAGGIO.....PAG6

INDEX

GENERALS.....PAG 3
ELECTRICAL PINS.....PAG 4
TIGHTENING TORQUE CHART.....PAG 6

GENERALITÀ

Il presente bollettino tecnico descrive la corretta coppia di serraggio da applicare alla viteria installata sui compressori prodotti da Officine Mario Dorin appartenenti alle seguenti gamme:

Serie H**Serie HI****Serie TH****Serie HEX****Serie HEP****Serie 2S-H****Serie CD****Serie CDS****Serie CD2S**

Per un corretto funzionamento del compressore si raccomanda di eseguire il serraggio della viteria secondo le coppie di serraggio riportate nelle pagine sottostanti.

Il compressore è atto ad essere inserito nell'elenco macchine definito dalla Direttiva Macchine 2006/42/CE; il compressore è conforme alla Direttiva Bassa Tensione 2014/35/UE.

Per maggiori informazioni sulle norme applicate controllare le dichiarazioni di incorporazione pubblicate sul nostro sito internet www.dorin.com o contattare il nostro ufficio tecnico-commerciale.

I compressori semiermetici sono esclusi dalla direttiva per gli apparecchi in pressione 2017/68/UE.

Le normative nazionali e locali che riguardano aspetti non coperti dalle norme sopra citate devono essere comunque applicate.

Il rispetto di tali regole deve essere di volta in volta assicurato.

OFFICINE MARIO DORIN S.p.A. fa uso dei più avanzati metodi per garantire la sicurezza e la conformità del macchinario fornito, sia esso nuovo o revisionato.

Pertanto qualsiasi operazione di smontaggio o modifica, che vada ad essere fatta sul compressore e/o gruppo, può pregiudicare la iniziale conformità del prodotto alle norme e direttive applicabili

Le OFFICINE MARIO DORIN S.p.A. non possono riconoscere o garantire la conformità dei propri prodotti alle attuali norme e direttive cogenti qualora gli stessi NON venissero revisionati dalla stessa casa costruttrice. Di conseguenza si informa che, qualora necessario, il compressore dovrà essere mantenuto e riparato esclusivamente da OFFICINE DORIN S.p.A.

Infatti OFFICINE MARIO DORIN S.p.A. assicura la rispondenza alle norme cogenti di ogni proprio prodotto internamente revisionato tramite collaudi appositamente predisposti.

OFFICINE MARIO DORIN S.p.A. declina ogni tipo di responsabilità qualora si verificassero danni a persone o cose derivanti da qualsiasi malfunzionamento di ogni proprio prodotto qualora quest'ultimo NON sia stato revisionato dalla stessa casa costruttrice.

GENERALS

This bulletin describes the tightening torque recommended on the screws installed on the following compressor ranges produced by Officine Mario Dorin:

H range**HI range****TH range****HEX range****HEP range****2S-H range****CD range****CDS range****CD2S range**

For correct compressor operation, we recommend to tighten the screws and the bolts at tightening torques indicated on following pages.

The compressor is included in the machine list defined by Machines Directive 2006/42/CE; the compressor compliant to the Low Voltage Directive 2014/35/UE.

For more information about applied normative, download the declaration of incorporation from our web site www.dorin.com or contact our technical-commercial office.

Semi-hermetic compressors are excluded from the scope of the directive for devices under pressure 2014/68/UE.

All the national and local regulations concerning any aspects which do not fall within above-mentioned directive must be applied.

The observance of such regulations shall be guaranteed from time to time.

OFFICINE MARIO DORIN uses the most advanced studies in order to guaranty the safety and the conformity of the products, both in case it is a new one or an overhauled one.

Any disassembly action or modification made on any DORIN product can affect product compliance to the aforesaid directives.

DORIN will not recognize/guarantee product conformity to the aforesaid directives whenever the products are NOT overhauled from DORIN itself. Therefore, any DORIN product shall be repaired from DORIN only since DORIN is the only able to guarantee overhauled product conformity to existing directives thanks to specific check controls.

In fact, OFFICINE MARIO DORIN S.p.A. ensures the compliance to aforesaid normative of any overhauled compressor by dedicated quality and safety tests.

Therefore, OFFICINE MARIO DORIN S.p.A. declines any type of responsibility in case damages of any nature occurs to things or persons due to product malfunctioning in case the product have NOT been overhauled from DORIN itself.

PASSANTI ELETTRICI

Per il serraggio dei capocorda e dei ponticelli sui passanti di collegamento riferirsi ai seguenti valori raccomandati:

M5 2,8 Nm

M6 6 Nm

M8 12 Nm

M10 25 Nm

ed alla figura successiva, che viene sempre allegata al kit di prima installazione dei compressori. Si raccomanda di eseguire scrupolosamente le indicazioni ivi riportate in fase di collegamento elettrico del compressore.

ELECTRICAL PINS

In order to tighten the nut related to bridges and cable on the electrical pin kindly refer to following values:

M5 2,8 Nm

M6 6 Nm

M8 12 Nm

M10 25 Nm

and to following pictures, which is always included in first installation kit supplied with the compressor. We recommend to stricly follow the instruction shown into the picture for correct compressor electrical connection.

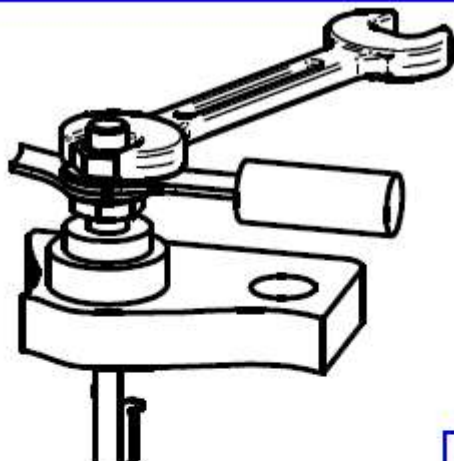
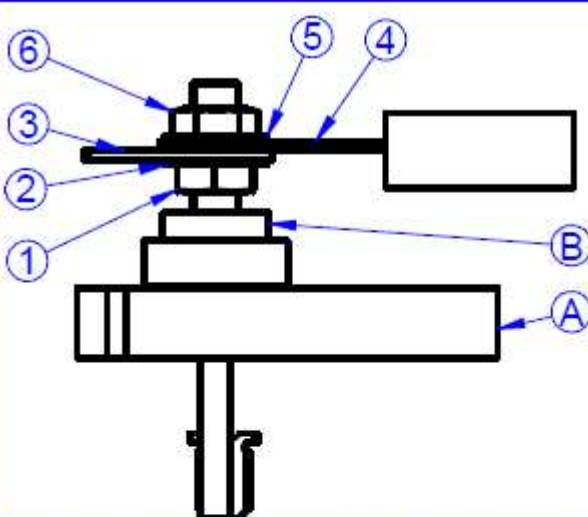
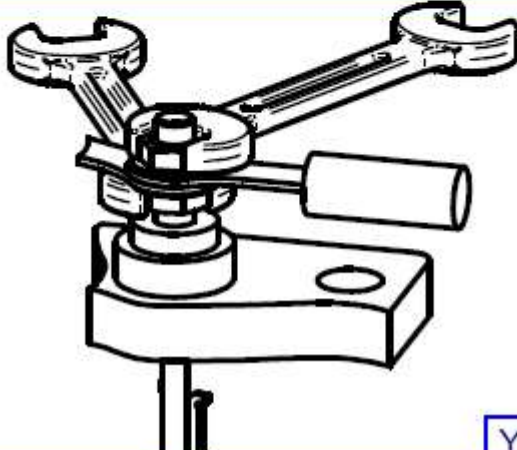
					
	<table border="1"> <tr> <td data-bbox="782 638 1085 873"> A piastra attacchi elettrici B isolamento passanti 1 dado 2 rondella 3 ponticello 4 cavo 5 rondella 6 dado </td> <td data-bbox="1133 638 1476 873"> A electrical connection plate B electrical insulation 1 nut 2 washer 3 bridge 4 cable 5 washer 6 nut </td> </tr> <tr> <td data-bbox="782 907 1197 985"> Massima Coppia di serraggio Maximum Torque </td> <td data-bbox="1244 873 1476 1019"> M5 = 2,8 Nm M6 = 6 Nm M8 = 12 Nm M10 = 25 Nm </td> </tr> </table>	A piastra attacchi elettrici B isolamento passanti 1 dado 2 rondella 3 ponticello 4 cavo 5 rondella 6 dado	A electrical connection plate B electrical insulation 1 nut 2 washer 3 bridge 4 cable 5 washer 6 nut	Massima Coppia di serraggio Maximum Torque	M5 = 2,8 Nm M6 = 6 Nm M8 = 12 Nm M10 = 25 Nm
A piastra attacchi elettrici B isolamento passanti 1 dado 2 rondella 3 ponticello 4 cavo 5 rondella 6 dado	A electrical connection plate B electrical insulation 1 nut 2 washer 3 bridge 4 cable 5 washer 6 nut				
Massima Coppia di serraggio Maximum Torque	M5 = 2,8 Nm M6 = 6 Nm M8 = 12 Nm M10 = 25 Nm				
NO	data 17-12-2020 1LTG042 04				

					
	<table border="1"> <tr> <td data-bbox="782 1612 1149 1848"> A plaque connecteur électriques B isolation électrique 1 écrou 2 rondelle 3 barrette 4 câble 5 rondelle 6 écrou </td> <td data-bbox="1173 1612 1476 1848"> A Elektrical platte B KabelKlemmSchraube 1 die Mutter 2 Unterlegsscheibe 3 der Schaltdraht 4 das Speisekabel 5 Unterlegsscheibe 6 die Mutter </td> </tr> <tr> <td data-bbox="782 1870 1117 1948"> Maximal Torque Maximale Drehmoment </td> <td data-bbox="1244 1848 1476 1993"> M5 = 2,8 Nm M6 = 6 Nm M8 = 12 Nm M10 = 25 Nm </td> </tr> </table>	A plaque connecteur électriques B isolation électrique 1 écrou 2 rondelle 3 barrette 4 câble 5 rondelle 6 écrou	A Elektrical platte B KabelKlemmSchraube 1 die Mutter 2 Unterlegsscheibe 3 der Schaltdraht 4 das Speisekabel 5 Unterlegsscheibe 6 die Mutter	Maximal Torque Maximale Drehmoment	M5 = 2,8 Nm M6 = 6 Nm M8 = 12 Nm M10 = 25 Nm
A plaque connecteur électriques B isolation électrique 1 écrou 2 rondelle 3 barrette 4 câble 5 rondelle 6 écrou	A Elektrical platte B KabelKlemmSchraube 1 die Mutter 2 Unterlegsscheibe 3 der Schaltdraht 4 das Speisekabel 5 Unterlegsscheibe 6 die Mutter				
Maximal Torque Maximale Drehmoment	M5 = 2,8 Nm M6 = 6 Nm M8 = 12 Nm M10 = 25 Nm				
NO	data 17-12-2020 n° 1LTG042 04				

TABELLE COPPIE DI SERRAGGIO

NB: le coppie di serraggio indicate nelle tabelle seguenti si riferiscono alle viti originariamente installate sui compressori prodotti da OFFICINE MARIO DORIN. In caso sia necessario sostituire le viti originali si raccomanda di utilizzare viti di PARI CLASSE DI RESISTENZA.

Per il serraggio delle viti è fortemente raccomandato l'uso della chiave dinamometrica.

TIGHTENING TORQUE CHART

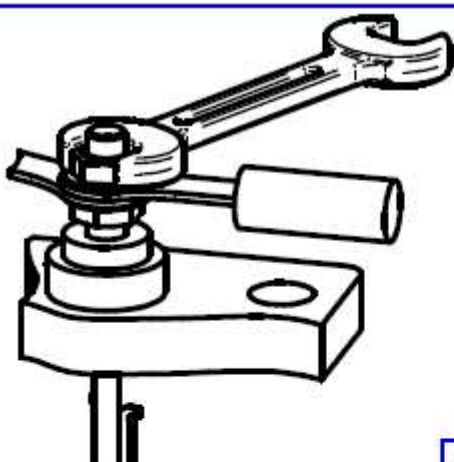
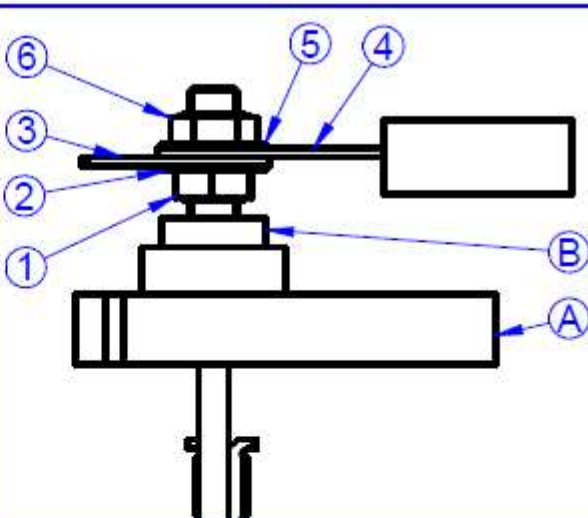
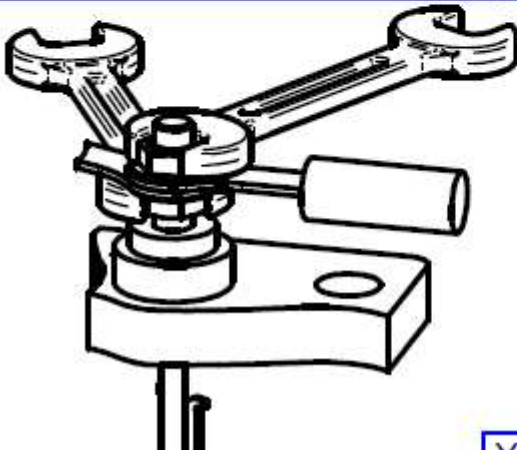
NB: tightening torques indicated in following table are related to screws originally installed on compressors produced by OFFICINE MARIO DORIN.

In case of replacement, replace original screws with new screws of the same CLASS OF RESISTANCE.

In order to correctly tighten the screws, the dynamometric wrench is strongly recommended.

TIPO COMPRESSORE COMPRESSOR MODEL	TESTA HEAD		COPERTURA CILINDRI CYLINDER COVER		MOZZO POMPA PUMP HUB		COPERTURA MOTORE MOTOR COVER		COLLETTORE SCARICO DISCHARGE MANIFOLE		BIELLA CONNECTING ROD		RUBINETTO ASPIRAZIONE SUCTION SERVICE VALVE		RUBINETTO COMPRESSIONE DISCHARGE SERVICE VALVE		GHIERA SPIA OIL SIGHT GLASS RING	
	Ø	Nm	Ø	Nm	Ø	Nm	Ø	Nm	Ø	Nm	Ø	Nm	Ø	Nm	Ø	Nm	Ø	Nm
H11/HEX11	M8	40	M8	40	-	40	M8	40	-	-	M8	40	M8	40	11*1/8	80	11*1/8	80
	10.9		10.9				10.9				12.9		12.9		UNEF		UNEF	
H2/HEX2	M10	80	M8	40	-	40	M8	40	-	-	M8	40	M8	40	11*1/8	80	11*1/8	80
	10.9		10.9				10.9				12.9		12.9		UNEF		UNEF	
H33/HEX33	M10	80	M10	80	-	80	M10	80	-	-	M10	80	M10	80	11*1/8	80	11*1/8	80
	10.9		10.9				10.9				12.9		12.9		UNEF		UNEF	
H35/HEX35	M10	80	M10	80	-	80	M10	80	-	-	M10	80	M10	80	11*1/8	80	11*1/8	80
	10.9		10.9				10.9				12.9		12.9		UNEF		UNEF	
H41/HEX41	M10	80	M10	80	-	80	M10	80	-	-	M10	80	M10	80	M6	16	M6	16
	10.9		10.9				10.9				12.9		12.9		10.9		10.9	
H5/HEX5	M12	120	-	-	M10	80	M12	120	-	-	M8	25	M10	80	M6	16	M6	16
	10.9				10.9		10.9			12.9		12.9		10.9	10.9	10.9	10.9	10.9
H55	M10	80	-	-	M10	80	M12	120	M12	120	M7	16	M12	120	M6	16	M6	16
	10.9				10.9		10.9		12.9		8.8		12.9		10.9		10.9	
H6/HEX6	M12	120	-	-	M10	80	M12	120	-	-	M8	25	M12	120	M6	16	M6	16
	10.9				10.9		10.9			12.9		12.9		10.9	10.9	10.9	10.9	10.9
H7/HEX7	M12	120	-	-	M10	80	M12	120	-	-	M8	25	M12	120	M6	16	M6	16
	10.9				10.9		10.9			12.9		12.9		10.9	10.9	10.9	10.9	10.9

TIPO COMPRESSORE COMPRESSOR MODEL	VALVOLA DI SICUREZZA SAFETY VALVE		DISCO OLIO OIL DISK		FONDO BOTTOM		SCATOLA ATTACCHI ELETRICI ELECTRICAL BOX		SERAGGIO ROTORE ROTOR SCREW		PIASTRA ATTACCHI ELETRICI ELECTRICAL PLATE		TAPPO SCARICO OLIO OIL DRAIN PLUG		TAPPO CARICO OLIO OIL CHARGE PLUG	
	Ø	Nm	Ø	Nm	Ø	Nm	Ø	Nm	Ø	Nm	Ø	Nm	Ø	Nm	Ø	Nm
H11/HEX11			M8 10.9	19	-	-	M6 8.8	6	M10 10.9	40	M8 10.9	40	-	-	M12 8.8	50
H2/HEX2			M6 12.9	19	-	-	M6 8.8	6	M10 10.9	40	M8 10.9	40	-	-	M12 8.8	50
H33/HEX33			M6 12.9	19	-	-	M6 8.8	6	M10 10.9	40	M8 10.9	40	-	-	M12 8.8	50
H35/HEX35			M8 10.9	19	-	-	M6 8.8	6	M10 10.9	40	M8 10.9	40	M12 8.8	80	M12 8.8	50
H41/HEX41			M8 10.9	19	-	-	M6 8.8	6	M10 10.9	40	M8 10.9	40	M12 8.8	80	M12 8.8	50
H5/HEX5		80	-	-	M10 10.9	80	M6 8.8	6	M12 10.9	80	M8 10.9	40	M12 8.8	80	M12 8.8	50
H55		80	-	-	M10 10.9	80	M6 8.8	6	M12 10.9	80	M8 10.9	40	M12 8.8	80	M12 8.8	50
H6/HEX6		80	-	-	M10 10.9	80	M6 8.8	6	M12 10.9	80	M8 10.9	40	M12 8.8	80	M12 8.8	50
H7/HEX7		80	-	-	M10 10.9	80	M6 8.8	6	M12 10.9	80	M8 10.9	40	M12 8.8	80	M12 8.8	50

TIPO COMPRESSORE COMPRESSOR TYPE	TESTA HEAD		COPERCHIO CILINDRI CYLINDER COVER		COPERCHIO MOTORE MOTOR COVER		COPERCHIO POMPA PUMP HUB		COLLETORE SCARICO DISCHARGE MANIFOLD		BIELLA CONNECTING ROD		RUBINETTO ASPIRAZIONE SUCTION SERVICE VALVE		RUBINETTO COMPRESSIONE DISCHARGE SERVICE VALVE		GHIERA SPIA OIL SIGHT GLASS RING	
	Ø	Nm	Ø	Nm	Ø	Nm	Ø	Nm	Ø	Nm	Ø	Nm	Ø	Nm	Ø	Nm	Ø	Nm
CDS11	M8	40	M8	40	M8	40							M8	28	M8	28	1"1/8	80
	10.9		10.9		10.9		8.8		8.8		18							
											UNE F							
CDS35	M10	80	M10	80	M10	80							M10	54	M10	54	1"1/8	80
	10.9		10.9		10.9		8.8		8.8		18							
											UNE F							
CDS41	M10	80	M10	80	M10	80							M10	54	M10	54	M6 12.9	16
	10.9		10.9		10.9		8.8		8.8									
CD200	M10	80	M10	80	M10	80							M10	54	M10	54	M6 12.9	16
	10.9		10.9		10.9		8.8		8.8									
CD4	M10	80	M10	80	M10	80							M10	54	M10	54	1"1/8	80
	10.9		10.9		10.9		8.8		8.8									
CD400	M12	140	M12	140	M12	140	M12	140	M12	140	M8	25	M12	94	M12	94	M6	16
	12.9		12.9		12.9		10.9		8.8		12.9							
CD600		-		-		140		140		140	M8	25	M12	94	M12	94	M6	16
							10.9		8.8		12.9							

TIPO COMPRESSORE COMPRESSOR TYPE	DISCO OLIO OIL DISK		VALVOLA DI SICUREZZA* PRESSURE RELIEF VALVE*		SCATOLA ATTACCHI ELETTRICI ELECTRICAL BOX		SERAGGIO ROTORE ROTOR SCREW		PIASTRA ATTACCHI ELETTRICI ELECTRICAL PLATE		TAPPO SCARICO OLIO OIL DISCHARGE PLUG		TAPPO CARICO OLIO OIL CHARGE		FILTRO ASPIRAZIONE SUCTION FILTER	
	Ø	Nm	Ø	Nm	Ø	Nm	Ø	Nm	Ø	Nm	Ø	Nm	Ø	Nm	Ø	Nm
CDS11	M8	19	M6	6	M10	40	M8	40	M12	80	M12	50	M12	50		
	10.9		8.8		10.9		10.9		10.9		8.8		8.8			
CDS35	M8	19	M6	6	M10	40	M8	40	M12	80	M12	50	M12	50		
	10.9		8.8		10.9		10.9		10.9		8.8		8.8			
CDS41	M8	19	M6	6	M12	40	M8	40	M12	80	M12	50	M12	50	M6	11
	10.9		8.8		10.9		10.9		10.9		8.8		8.8		8.8	
CD200	M6	19	M6	6	M10	40	M8	40	M8	40	M12	50	M12	50	M6	11
	12.9		8.8		10.9		12.9		12.9		8.8		8.8		8.8	
CD4	M6	19	M6	6	M10	40	M8	40	M8	40	M12	50	M12	50		
	12.9		8.8		10.9		12.9		12.9		8.8		8.8			
CD400	M8	19	M6	6	M12	70	M10	80	M10	80	M12	80	M12	50	M6	11
	10.9		8.8		10.9		12.9		12.9		8.8		8.8		8.8	
CD600	-	-	M6	6	M16	70	M12	140	M12	40	M12	90	M12	50		
			8.8		10.9		10.9		12.9		8.8		8.8			

***ATTENZIONE: LE VALVOLE DI SICUREZZA DI ALTA PRESSIONE INSTALLATE SUI COLLETTORI DI SCARICO DEI COMPRESSORI DELLA GAMME CD400 E CD600 SONO DOTATE DI FILETTATURA SINISTRORSA**

***WARNING: HIGH PRESSURE RELIEF VALVES INSTALLED ON CD400 AND CD600 DISCHARGE MANIFOLD ARE EQUIPPED WITH LEFT HAND THREAD.**



OFFICINE MARIO DORIN SINCE 1918

DORIN[®]
INNOVATION

OFFICINE MARIO DORIN S.p.A.

Via Aretina 388, 50061 Compiobbi - Florence, Italy
Tel. +39 055 62321 1 - Fax +39 055 62321 380

dorin@dorin.com
www.dorin.com