

Note this is NEW v2 Model instruction!

INSTALLATION & PROGRAMMING

Phasefale's TACmv2 new model with Data logging & Real time Clock!

INDEX

1. Installation
2. Programming
 - 2a. AA1 (advanced) Prog.
 - 2b. AA2 (clock) Prog.
 - 2c. Lod (USB+default) Prog.
- Changing Software
- Default Profiles
- Save settings to a USB
- Read settings from a USB
- 2d. A Programming Example
3. Cooling and Heating
4. Alarm
5. Defrost [Real Time Defrosts]
6. Temperature Logging
7. Firmware upgrades
8. Enclosure Mounting
9. Alphabetical Table of Indications
10. TACm Wiring Diagram

General Overview and Introduction

Phasefale's new TACm is extremely simple to set up and operate and now has many new features including, real time clock for defrosts and a USB port. Temperature is logged to a memory stick and settings can be read and written to a memory stick. The temperature is shown on the LED display. If cooling or heating operations are occurring a point is displayed at the end of the temperature display. Flashing of the temperature indicates an alarm situation. During defrost, **dF** is displayed. The programmed settings may be viewed by pressing the M button for 2 seconds. All settings are held in memory even during power loss.

1. INSTALLATION

Enclosure Installation

Please refer to the mounting instructions Section 8.

Real Time Clock (RTC) - battery activation

The RTC battery has a plastic insulator (right hand side of PCB) to save the battery during storage. **Remove** the insulator before commissioning to activate RTC time keeping. Temperature Sensor (M Probe) Installation

The temperature sensor is an NTC thermistor of extreme accuracy (0.2°C), and it has a non linear resistance temperature characteristic (see chart below). It is ideally mounted in a position where refrigerated air is circulating.

At least 150mm of the sensor cable must be in the refrigerated space to ensure accurate temperature sensing.

If the sensor cable is open or short circuit, the TACm will display **Er** to indicate the fault. If a defrost terminate probe is used it should be mounted centrally in the evaporator coil.

The sensor cable is double insulated and therefore does not need to be enclosed in a conduit. There is no polarity to the sensor connection and it may be extended up to 100 metres by joining an extra cable (use double insulated cable) but the join must be well insulated and away from any dirt or moisture.

Dirt or moisture at the join will reduce the resistance of the

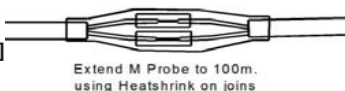
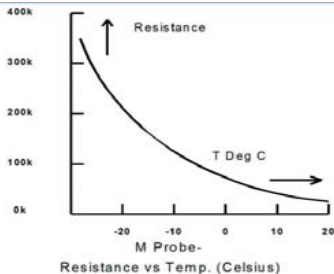

probe and result in a higher temperature reading than normal.

Electrical Installation

Refer also to the electrical wiring diagram for connection details.

The Active supply to the unit should be fused with a maximum rating of 10A. The control and light outputs are rated at 10A resistive.



Motors larger than 1 HP MUST be switched via a relay or contactor

The dialler output provides alarm contacts that open on alarm or power loss. The contacts can be connected to Phasefale's AD3 telephone dialler to provide a remote alarm using existing phone lines.

If an AD3 is connected, the +12 and GND terminals can be used to supply 12V DC to the dialler. The correct polarity is indicated on the wiring diagram. We recommend a battery backup is fitted, connect the AD3 to the battery.

If a battery back-up (TACm/PSB30) unit is to be used to supply 12V DC to the AD3, it may also be used to supply back-up power to the TACm by connecting L and G from the TACm/PSB30 to +12 and GND on the TACm. The TACm/PSB30 is supplied with the battery + lead disconnected. Reconnect once mains power is connected.

If the mdPCB option for heater and fan outputs is to be fitted, follow the instructions supplied with it. The optional toggle defrost, synchronizing time, terminate defrost, distress, clear memory and acknowledge inputs are extra low voltage inputs and require voltage free contacts. Closing the contacts momentarily will initiate the function. Refer to the wiring diagram for correct wiring of these inputs.

The optional Alarm Isolate input requires voltage free contacts and is active while the contacts remain closed.

Installation Self Test **M and ^**

Press **M** and **>** together for 5 seconds. The TACm automatically cycles its outputs in the following sequence:

Display	Action	secs.
CO/CF	Cooling On & Off	10/4
LO/LF	Light On & Off	4/4
DO/DF	Dialler On & Off	4/4
BO/BF	Buzzer On & Off	4/4
HO/HF	Heater On & Off	4/4
FO/FF	Fan On & Off	4/4

2. PROGRAMMING

The basic programming steps are:

- “Unlock” the TACm’s memory for programming
- Select the setting to be adjusted.
- Alter the setting to your desired value.
- Store the changed value.
- Return to normal operation.

a) To unlock the TACm and alter the settings, press **M** and **>** together for 5 seconds. UL will be displayed to indicate that the system is unlocked.

b) After the TACm is unlocked press **M** until the setting you wish to alter is displayed. The settings are displayed sequentially as in the table below:

UL Basic Menu Table

Setting	Meaning, adjustable range
SP	Control Setpoint °C (-80~ +150°C) CUTIN
dl	Differential Temp °C 0.1~5°C, Ec:economy
AH	High Alarm Temp. °C (-100~ +150°C)
AL	Low Alarm Temp. °C (-100~+150°C)
At	Alarm Time Delay (0~240 minutes)
nd	Number of defrosts per 24hr (0~12)
dd	Defrost duration (1~240minutes)

c) After the setting to be adjusted is displayed, you can increase or decrease the setting by pressing **^** or **v** until the numerical value required is displayed.

d) To store the changed value, press the **M** button. The new value is now stored indefinitely and will remain during power loss.

e) If no button is pressed for 60 seconds the TACm will once again lock itself and further alterations will be disallowed until unlocked again. This will also occur if the **>** key is pressed during the programming operation.

Remember! store each altered value using **M**

2a. ADVANCED [AA¹menu] PROGRAMMING OPTIONS

A further series of functions and commands can be accessed during the Unlocking stage by simply pressing the **M** and **>** keys for a total of 10 seconds, at which time the symbol **AA¹** is displayed. Program items that can be accessed in the advanced menu are indicated in the table in the next column and are explained under their appropriate function headings. The current software version for the TACm is v41 you can see the current software version at the end of the **AA¹** menu.

2b. Real Time Clock – RTC [AA² menu] PROGRAMMING OPTIONS

By holding down **M** and **>** buttons for a total of 15 seconds you can access the Real Time Clock Menu. To set the time* in minutes simply use the up **^** and down **v** arrow to select the value and press **M** to save the value into memory and then you can set the hours repeat this process for the day, the month and the year. * *ensure insulator is removed.*

2c. Load Defaults [LOd menu] PROGRAMMING OPTIONS

To load defaults **M** and **>** buttons for 20 seconds. There are currently 2 sets of load defaults built into the TACm

software although provision is made to add more in future.

AA¹ - Advanced Menu Table

Setting	Dflt	Meaning, adjustable range
AA	10	Alarm Acknowledge (0-240) mins
LS	4	Limit Start time (0-99) mins
tr	5	Defrost terminate [using Mprobe] or range value [using pot.] (8~15°C)
Co/He	Co	Cooling or Heating
dt	0	Heater drain time (0-12) mins
Ft	0	Fan delay/pump down time (0-4.0 m)
dE/dg	dE	Electric or Hot Gas Defrost
tE/rA	tE	S2 input function terminate or range via external potentiometer (0-100k)
Sd/Hd	Sd	Show or Hide dF during defrost
St1	02.0	1st Defrost time- hrs:min (24 hr clk)
St2	08.0	2nd Defrost time- hrs:min (24 hr clk)
St3.	14.0	3rd Defrost time- hrs:min (24 hr clk)
St4	20.0	4th Defrost time- hrs:min (24 hr clk)
St5	-	5tht Defrost time- hrs:min (24 hr clk)
...	-	depending on nd setting 0-12 def=4
St12	-	12th defrost time
doA	oFF	Door alarm (oFF,noA, 1,2...60 min.)
Fod	oFF	FanOff [with door open] (oFF,1,2...30 min)
CA	0.0	Calibration Offset (-9.9~+9.9°C)

AA² - Clock Settings Menu Table

Setting	Meaning, adjustable range
°C/°F	Celsius or Fahrenheit Temperature range
t1n	Minutes (0-59)
t1h	Hours (0-23)
dtD	Day (1-31)
dtN	Month (1-12)
dtY	Year (10-20)

Lod-Load & USB Menu Table

Setting	Meaning, adjustable range
Out	Save Settings TO setting.txt on USB memory stick
Usb	load Settings FROM setting.txt on USB memory stick
no	do not load defaults
dF1	load DF1 cool room defaults
dF2	load DF2 Freezer defaults
dFr	*special function “r”
dFv	*special function “v”
	* contact Phasefale for details

Default Profiles

The default profiles for the cool room and freezer room make the programming for these jobs easier. Load the default profile that is compatible with the job. Finish by fine tuning the individual attributes to match your jobs needs. Contact Phasefale if you have a set of parameters you would like added to the TACm for regular use.

Setting	dF1 - cool room	dF2 - Freezer Room
SP	4	-18
dl	1	3
AH	10	-10
AL	1	-23
At	90	90
nd	4	4
dd	30	25

Save Settings to USB

Settings can be written to a file on the USB stick. To do this go to the LOD menu as in Load Defaults and select the OUT option and press M. The settings are written to a file called SETTING.TXT which can be edited with a plain text editor. The setting values are written as integers as stored in the processor, for example 1C will be written to the file as value 10 because the internal resolution of temperatures is 0.1C.

Read Settings from USB

To read the SETTING.TXT file into the TACm access the LOD menu select the USB option and press M. The settings will be read from the USB stick and stored in the processor.

2d. A PROGRAMMING EXAMPLE

A small fruit room needs to be controlled at 1.0°C. We want a high alarm at 9.0°C and a low alarm at 2.0°C to prevent the fruit from freezing. Being a small room, we will set the alarm time to 60 minutes. As we are energy conscious, we will use the economy mode of operation. We want two 45 minute defrosts per day.

Step 1 Use the auto-setup to load suitable settings:

- Unlock the TACm using **M** and **>** keys. Display reads **UL**, then...
- Display shows **SP** eg. 5.0.
- Decrease the CUTIN setpoint by pressing **v** until 1.0 is displayed.
- Store the new setpoint with **M**.

• **dl** (for differential) then **Ec** (Economy mode*) is displayed.

• Press **v** and **AU** (Automatic mode*) is displayed.

• Store the automatic setting with **M** key.

* There are three programming options in differential **dl** :

Ec Economy mode a method to reduce energy usage whilst using the internal limit start timer to protect the compressor.

AU Auto setup Default settings (for all the programmable values) based on your setpoint are loaded into the TACm's memory.

0.5 to 5.0 Differential Temperature in °C The specific temperature required for the control. (See Cooling and Heating Operations)

Step 2 The TACm has stored those values, but we now "fine tune" the settings for our application:

- Unlock the TACm: **M** and **>**
- Display **UL**.
- **SP** then **1.0** is displayed, press **M**
- **dl** then **EC** is displayed, press **M**.
- **AH** then **14** is displayed, decrease the high alarm to **9.0** using **v** Store the new high alarm setting with **M**.
- **AL** then **4.0** is displayed, increase the low alarm setting to 2.0 using **^**
- Store the new low setting using **M**
- **At** then **90** is displayed, decrease the alarm time delay to **60** using **v**, then store with **M**.

• **nd** then **1** is displayed. We want 2 defrosts so press **v** then **M** to store.

• **dd** then **30** is displayed, set the defrost duration to **45** and store with **M**

Step 3 Check our Settings

Press **M** for 2 seconds, and our stored values are automatically displayed.

The TACm is now ready for operation.

3. COOLING AND HEATING OPERATIONS

Heating and cooling control is between the setpoint **SP** (CUT IN) and the setpoint minus the differential **dl**

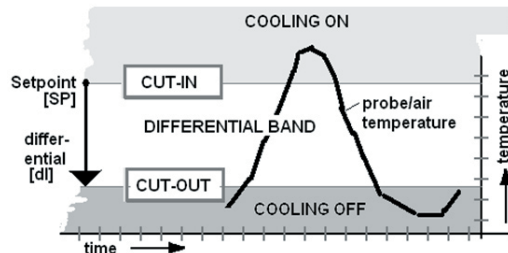

(cut out). For example: **SP** = 10°C, **dl** = 1.0°C: control between 9.0°C and 10°C. Another example: **SP** = 10°C, **dl** = 3.0°C: control between 10°C and 13°C.

The Heating and Cooling options **HE** and **Co** [**AA1** menu] select whether the C1/C2 output controls heaters or coolers. In heating mode there is no limit start timer or defrost function and programming options that relate to defrosts will be skipped. If Cooling is selected, a limit start timer protects against short cycling the compressor. The timer will prevent the cooling output turning on for a period starting the previous time the cooling output turned on. Once this period has elapsed the output is free to turn on as required. *A bleed resistor may be required for low load devices-see wiring drawing.Part TACmv9/RKIT.*



LS is the limit start delay which is the delay to stop unit switching on and off too often this is the anti short cycle timer for C1/C2. C1/C2 comes on when cooling is required, as shown in this diagram;

AA is the alarm acknowledge period the unit will not go into alarm again for this period of time once an alarm has been acknowledged.

tE/rA The terminate/range temperature function [**AA** menu] sets a temperature terminated defrost **tE** if a probe is connected (See Defrost), or it sets the range offset **rA** as described below:

An external trimpot of 100k Ohm value may be used to modify the control temperature up or down by 5, 10, 15

or 20°C as set by the tr setting. The programmed value **SP** then becomes the “midpoint” of the setpoint range. 0kOhm gives the minimum, 100kOhm gives the maximum and 50kOhm leaves the setpoint unchanged.

If no trimpot is connected, the setpoint remains unaltered. The high and low alarm temperatures **AH**, **AL** will be shifted in conjunction with the setpoint **SP**. Note that **SP**, **AH** and **AL** will reflect the altered setpoints when viewed by pressing **M** from normal operations. By using fixed resistors, specific temperature setpoints can be set up using a rotary switch or time clock.

4. ALARM

The Alarm function has a high temperature (in °C) setpoint, **AH**, a low temperature (in °C), **AL**, and a time delay, **At**. If either setpoint is exceeded for longer than the time delay an alarm will occur. If cooling mode is selected the **low alarm** will occur in **1/4 of the time delay At**. The optional distress alarm will initiate an alarm immediately if connected, as will a power failure if the internal battery backup option is used.

An Alarm is indicated by the temperature display flashing accompanied by the sounding of a buzzer, a flashing alarm light and/or a dial signal if these accessories are connected.

An alarm may be acknowledged by pressing **>** momentarily or via an external switch. The light will then be steady on and the buzzer and dialler off for the period set by **AA** [**AA1** menu]. The alarm will reoccur after this period of time unless the temperature returns to normal.

An Alarm Memory is shown by the display flashing but no other alarm indications. This indicates that an alarm has occurred but that the temperature has since returned to normal. It may be cleared by pressing the **□** button.

Door Alarm & Fan off Function [doA, Fod]

Connect a switch across S5 and GND- close/shorted is door close and open circuit= door open. It can be programmed as a monitor only (noA, or alarm 1-60 minutes.) The door status is monitored on the memory stick. Access from AA menu after defrosts. Fan OFF (Fod) occurs for a maximum time after the door opens from oFF (not used) to 1,2,...30 minutes.

HOT GAS If a hot gas defrost is used [dg in advanced menu], the light output cannot be used as an alarm light, the buzzer and dialler outputs still operate as normal during alarm.

5. DEFROST

The defrost duration **dd** is the time in minutes in which the refrigeration is switched off and the heaters are on. Defrosts are spaced at nominated times during the day and the number per day is set by nd.

.Press **^** to find out when the next defrost will occur, **td** is displayed, followed by the number of hours until the next defrost. Similarly, pressing **v** displays **Fd** followed by the number of hours since the last defrost occurred. The

decimal place represents 10 minutes, ie 2.4 is 2 hours and 40 minutes.

To initiate a Toggle Defrost, hold the **>** button for 1 second and either **dF** or **Co** will be displayed, to indicate whether the refrigeration is presently in defrost or cooling mode. Press the **^** button followed by **M** to initiate a defrost or press the **v** button followed by **M** to terminate a defrost. This function can also be accomplished with an external toggle defrost switch (which will alternate the status between defrost and cooling when closed) or via the terminate defrost input (which will terminate a defrost and initiate a drain period).

Further defrost functions can be accessed via [**AA**¹ menu]. The **Sd** (Show defrost) function alternates the display between **dF** and the temperature during defrosts, also the **dFd** defrost drain time and the **dFf** defrost fan time are also shown whilst in operation. whilst **Hd** (Hide defrost) causes the display to show only dF during defrost.

Also accessible [**AA**¹ menu], **St** refers to the Start Time of the first defrost. Defrosts will then occur at periods evenly spaced during the day as set by **nd** automatically by the TACm, but can be changed manually via **St1**, **St2**, etc.. So, groups of TACm's may be set to stage defrosts between them by selecting different start times for each unit, and synchronizing the time via the clock setting.

The Heater Drain Time **dt** [**AA**¹ menu] sets the period in minutes from the end of the defrost period **dd** until the cooling output is allowed to operate.

The **Ft** Fan Delay Time sets the period in minutes from the end of the drain time when cooling comes on to the time when the fans are allowed to operate. The decimal place The **dE/dg** (Electric/hot Gas defrost) [**AA**¹ menu] allows the unit to control Electric (Liquid,Heater and Fan) or Hot Gas (Liquid,Suction,Hot Gas and Fan) defrosts.

A Hot Gas defrost uses the Light output as the Suction solenoid control and the **Ft** setting as a pump down time. The Hot Gas output sequence is as follows..

Output	C	L	H	F	Time
Representing Liquid, Suction, Heater, Fan					
Cooling	on/off	on	off	on	
P/Dwn	off	on	off	on	Ft
Defrost	off	off	on	off	dd
Drain	off	off	off	off	dt
Fan	on/off	on	off	on	Ft
Cooling	on/off	on	off	on	

Real Time defrosts

One of the best new features of the new TACmv2 is the ability to program real time defrosts. Once you have programmed the real time clock into the controller using the Load Defaults Menu you can enter up to 12 real time defrosts. In the **UL** menu select the number of defrost

you want each 24 hours using the **nd** setting. The real time defrosts can be programmed by unlocking the **AA¹** menu and entering the time offsets for defrosts in the settings **St1-St12**.

Be sure to set the time in **AA²** so defrost times are correct, also battery insulator is removed!

A second **M** Probe may be used as a temperature termination sensor for the defrost. It is used between the GND & S2 outputs. The **tE/rA** setting should be set to **tE** and the defrost terminate temperature set by **tr** at 5, 10, 15 or 20° C.

6. TEMPERATURE LOGS USING MEMORY STICK

The TACm will automatically start logging temperature as soon as you plug a USB memory stick into the USB port. The sensor temperature and time will be logged once per minute to a file called **LOG.TXT**. Events such as alarms and programming will be appended with the current time to a file called **EVENTLOG.TXT**. For data logging applications it is important that the time and date is set correctly to ensure records are correct. Removing the USB memory is OK (no logs are stored while it is removed) and TACm will resume logging when the USB stick is re-inserted.

The RTC must be set correctly for logging- by removing the insulator AND set the correct time and date.



The USB plug provided can be left as is when logging is not required and no memory stick fitted. When logging is employed, cut 3 sides of the plug to allow a flap which raises for the memory stick as shown in the photo below.

7. FIRMWARE UPGRADES

Make a backup of settings first: firmware updates over-rite all programmed settings!

It is possible to upgrade the firmware to units in the field with a USB memory stick. Load **tacmv2_xx.hex*** (* Version 41 & higher; if this does not work, rename file to **tacmv2.hex** & retry) file onto a USB memory stick and

then plug your memory stick into the USB port. Power down the TACm and power back up again while holding all 4 keys down and with the USB in the USB port. After 5 seconds the display will toggle between the bottom two segments, then chase, then **tAc** will appear on the display before going into normal mode of operation. The new firmware will then be automatically loaded into the processor. Recycle power before re-programming.

For Technical assistance please contact :

PHASEFALE CONTROLS PTY LTD

83 Taunton Drive Cheltenham VIC. 3192, AUSTRALIA

Tel +613 95845590 www.phasefale.com.au sales2@phasefale.com.au

8.TACmv2: Enclosure installation/ Cable Routing

1

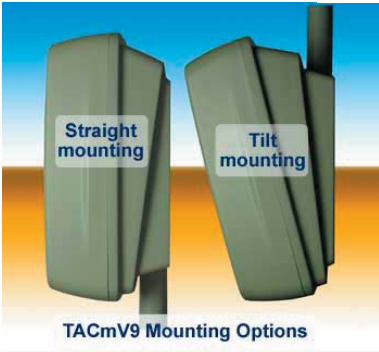

Decide if you want straight (left picture) or tilt mounting. The wall mount conduit entry points are at the bottom for straight mount and at the top for tilt (approx 15 degrees) mounting.

2

Mount the wall mount base using the 4 off 6mm mounting holes, centers are 90mm high x 72mm wide. (Fixings not included). For conduit entry, the cables for the TACmv can enter through the 2 x 19mm conduit entry points placed 30mm apart. Use a knife as shown to open out the holes. Alternatively, the cables can come through the rear of the mounting surface, simply drill a hole in the wall mount base.

For maximum safety, bring LV mains cables (e.g. 240 V AC supply, compressor/evaporator control, fan, heater and alarm light) in through a different conduit than the Extra Low voltage cables (e.g. Sensor cable, alarm isolate, defrost terminate, alarm buzzer and security etc.)



4

3

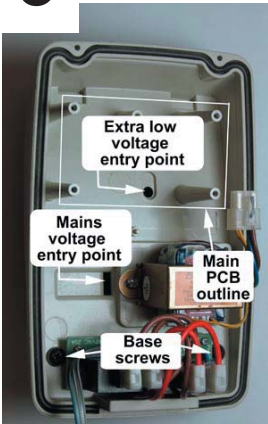

Before fitting the enclosure base over the wall mount base, feed the ELV cabling through the opening under the circuit board and up to the top of the board. The hole can be enlarged as required with a sharp knife. For maximum environmental protection, keep the hole as small as possible and later it can be silicone sealed. Similarly feed the LV mains cables through the rectangular slot, enlarging as required. For maximum safety, ensure LV and ELV cables are segregated. Locate the enclosure base over the wall mount base with the top 2 lugs and bottom screws provided

For an electric defrost system, the optional board is fitted at the bottom of the enclosure base using the 3 screws supplied. When fitting the Quick connect cable connectors, ensure they face upwards and are fully seated to prevent fouling the enclosure when it is fitted later



5

After all electrical connections have been made, with the ELV cables along the top of the main PCB and LV connections across the bottom, the enclosure cover can be fitted in the following sequence:

- ensure the circular rubber gasket is snug in the channel around the base.
- tilt the cover and locate it under the lug across the bottom of the enclosure base.
- swing the cover against the base and secure with the 2 supplied screws, for a complete seal tightening them so the gap between the base and cover is even around the whole perimeter.

9. Alphabetical List of Display Indications

AA1	Advanced Menu entry (~5secs)		Fd	from last defrost (hours)	
AA2	Clock Settings menu entry (~8secs)		FF	Fan OFF (o/p test)	
AA	Alarm Ack./Limit Start	10	FO	Fan ON (o/p test)	
AC	AC Mains Failure		Fod	Fan Off delay	0
AH	High Alarm temp. °C	13	Ft	Fan delay time mins	1
AL	Low Alarm temp °C	-5	Hd	Hide defrost temp °C	Sd
At	Alarm time delay mins	90	HE	Heating mode	Co
AU	Automatic setup		HF	Heater OFF (o/p test)	
bO	Buzzer On (o/p test)		H0	Heater ON (o/p test)	
bF	Buzzer Off (o/p test)		LF	Light OFF (o/p test)	
CA	Calibrate (AA1)	0	LS	Limit Start Time mins	4
Co	Cooling mode (AA1)	Co	Lod	Transfer (USB) menu entry (~10secs)	
CO	Cooling ON (o/p test)		LO	Light OFF (o/p test)	
CF	Cooling OFF (o/p test)		nd	number of defrosts	4
dd	defrost duration mins	30	no	exits the Load Defaults menu	
dE	Electric defrost	dE	noA	Door monitor (not alarmed)	
dF	Defrost or Dialler OFF		oC	Units in Celcius	°C
dg	Gas defrost	dE	oF	Units in Fahrenheit	
dl	Differential °C	Ec	Out	Save settings to USB: "setting.txt"	
dO	Dialler ON (o/p test)		PL	Power Loss	
doA	Door Alarm	oFF	rA	Range (via pot.)	tE
dro	Door is Open (displays w Temp)		Sd	Show temp during defrost	Sd
dt	Heater drain time mins	1	SP	Setpoint temperature	0.0
dF1	Cool Room Default		td	time to next defrost hourst	
dF2	Freezer Default		tE	temperature terminate	tE
dFf	Defrost Fan Time		t1n	Real time clock minutes	30
dFd	Defrost Drain Time		t1h	Real time clock hours	0
dtd	Real time clock days	1	tr	defrost termination/range°C	5
dtn	Real time clock months	1	UL	programming unlocked (~2 secs)	
dty	Real time clock years	20	USB	Read Settings from USB: "setting.txt"	
Ec	Economy mode	Ec	41	Software Version (displays after CAL)	
Er	Probe Error (open or short circuit)			Blue Entires are the default settings	

Note: Apart from S1/gnd all ELV connections are optional: use only as required

EXTRA LOW VOLTAGE WIRING TOP EDGE OF PCB

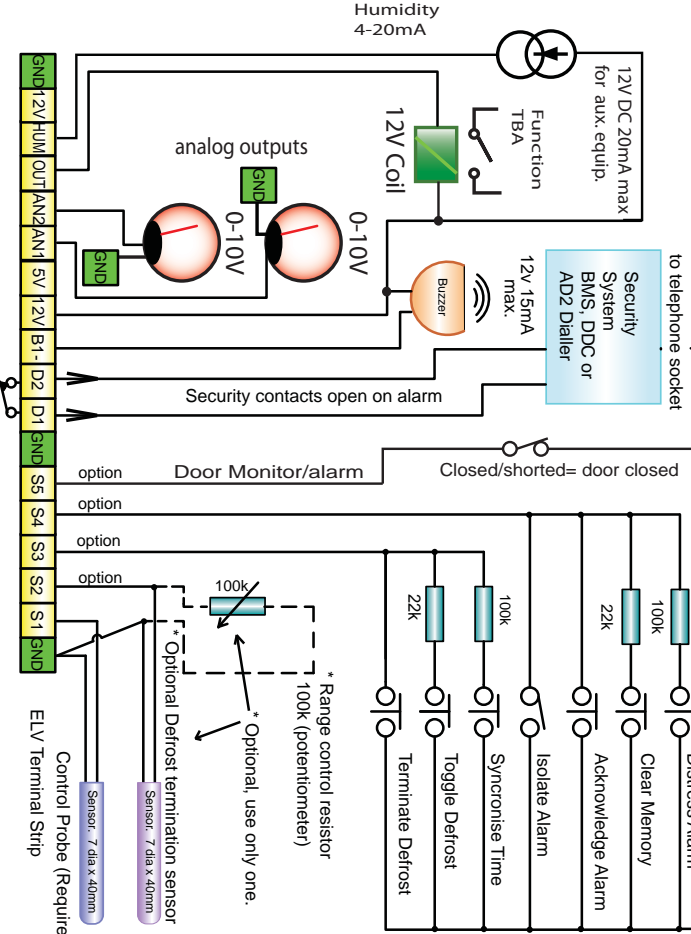

Note : These connections are to be voltage free

FAN HEATER OPTION BOARD IF FITTED

