

UNEK6210Z

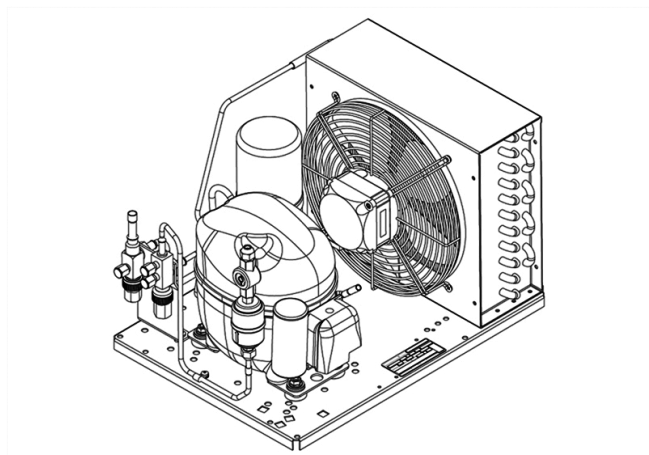

ENGINEERING CODE
558BAL812AA



REFRIGERANT
R-134a



POWER SUPPLY
220-240 V 50 Hz



APPLICATION
HBP



MOTOR TYPE
CSIR



STANDARD
ASHRAE



COOLING CAPACITY
1102 W



EFFICIENCY
2 W/W

CE

ECODESIGN COMPLIANT

DATA

GENERAL DATA

Model UNEK6210Z

ACCESSORIES

Dryer	FILTER DRYER 1/4" SAE	2730019
Sightglass	SIGHT GLASS 1/4" SAE	2464249
Discharge valve	SOLDER 1/4"	2110086
Suction valve	SOLDER 3/8"	2110060

CONDENSING COMPONENTS

Compressor	NEK6210Z	M/HBP
Condenser	3R11T	2451206
Refrigerant	R-134a	
Expansion Device	C-V	
Fan Blade Diameter	254	
Fankit	16W 254/28/5B	1996579

MECHANICAL DATA

Air Flow	595 m ³ /h
Height	296 mm
Receiver	1.1 L
Shaft Power	16
Weight	20 Kg
Width	340 mm
Length	474 mm

PERFORMANCE

TESTED CONDITIONS

Tested Refrigerant	R-134a
Tested Application	HBP
Tested Standard	ASHRAE

RATED POINTS

Ambient Temperature °C	Evaporating Temperature °C	Cooling Capacity W	Efficiency W/W	Consumo de Potencia W
32	7.2	1102	2	550

Test Condition: Subcooling 3 K, Return Gas 32 °C.

PERFORMANCE CURVE

Ambient Temperature 25°C

Evaporating Temperature °C	Cooling Capacity W	Efficiency W/W	Consumo de Potencia W
-15	544	1.61	339
-5	822	1.98	416
0	975	2.11	461
5	1138	2.23	511
10	1309	2.32	565

Test Condition: Subcooling 3 K, Return Gas 32 °C.

PERFORMANCE CURVE

Ambient Temperature 32°C

Evaporating Temperature °C	Cooling Capacity W	Efficiency W/W	Consumo de Potencia W
-15	495	1.42	349
-5	745	1.74	429
0	885	1.86	475
5	1033	1.96	526
10	1191	2.05	582

Test Condition: Subcooling 3 K, Return Gas 32 °C.

PERFORMANCE CURVE

Ambient Temperature 43°C

Evaporating Temperature °C	Cooling Capacity W	Efficiency W/W	Consumo de Potencia W
-15	382	1.04	366
-5	612	1.35	452
0	741	1.48	502
5	880	1.58	556

Test Condition: Subcooling 3 K, Return Gas 32 °C.

ENVELOPE

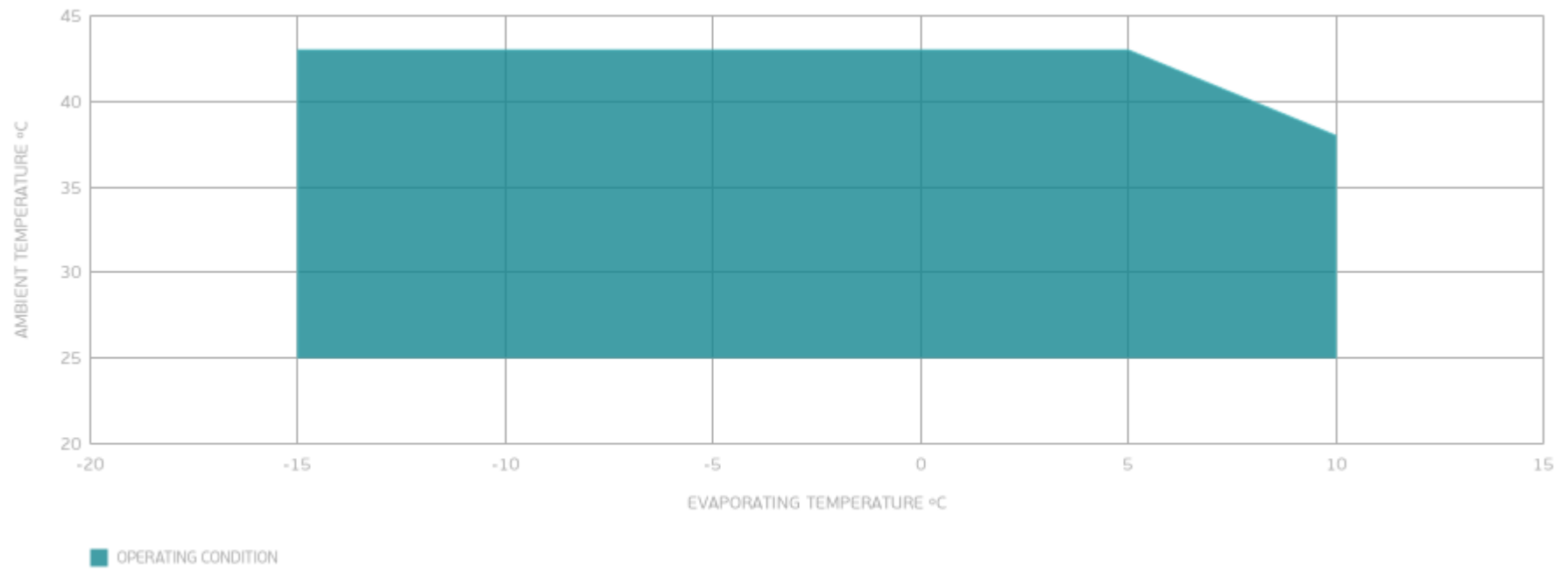

EXTERNAL DIMENSIONS

