

EMBRACO **CONDENSING UNITS**

BUILT FOR AUSTRALIAN HARSH CONDITIONS

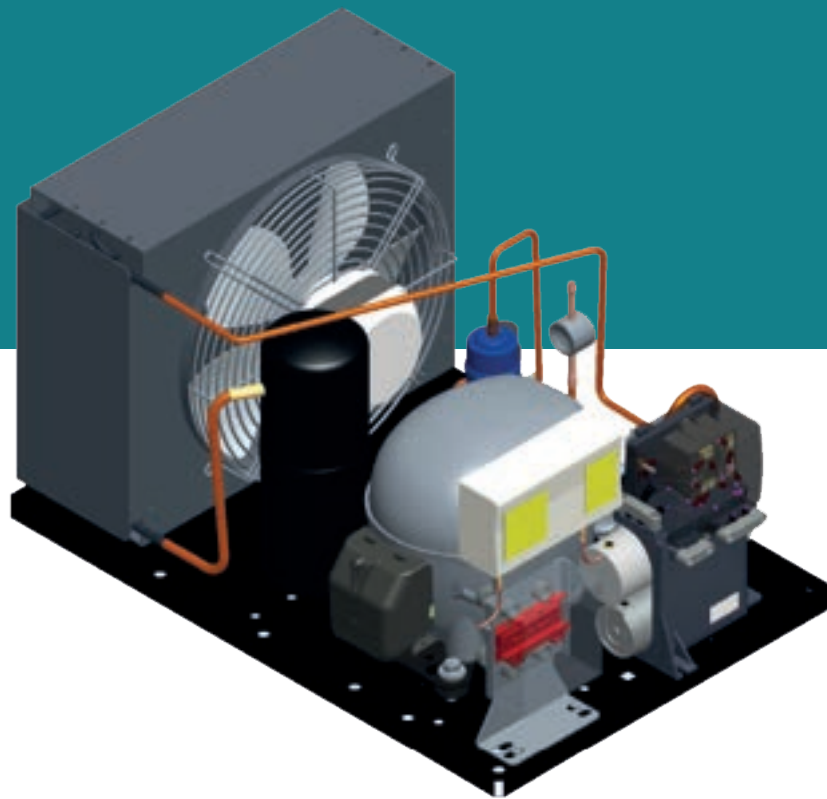

**Strong and complete
that the market needs**

embraco
Nidec

About

Developed for harsh Australian conditions, Embraco's new complete condensing units are a robust and reliable line up, rated up to 43°C ambient temperature.

Delivering the high performance the market needs.



Addresses your needs

- Ease of installation
- Designed to work up to 43°C ambient
- Complete capacity range up to 1.5Hp
- Additional features to improve usability

More Features More Complete

Now available with

- Oversized condenser and liquid receiver for high ambient condition
- High quality Embraco compressor
- Robust component brands

Designed around your application

Reach Ins; Undercounters
Prep Tables; Freezers; Cold Rooms

**And more food service,
food retail and hospitality
refrigeration applications.**



Condensing Units

Versions & Features

Embraco offers a **complete range of Condensing Units** along with a **wide variety of components** customized condensing units.

Check the components and features available

Plus	Embraco hermetic compressor
	Large Embraco condenser
	Factory wired single phase fan motors
	Liquid receiver
	HP/LP control
	Sight glass
	Filter dryer

Nomenclature Australia							
U	NEU	6215	G	-	K	A	07
Unit application	Compressors/CDU Family	Compressor Designation	Refrigerant		Voltage Supply	Condenser type	Accessories configuration
U Sub Tropical unit approved for 43°C ambient	EM EM FF FFU NEU NEU	Same nomenclature for compressor model naming	Z R134a G R404A U R290		D 220V/60Hz/1PH E 115 - 127V/60Hz/1PH K 220V/50Hz/1PH B 220V/50-60Hz/1PH S 400V 50Hz/ 440V 60Hz 3PH F 380V/60Hz/3PH H 220V/60Hz/3PH	A Air cooled Finned tube H Air cooled Helical tube W Water cooled plate heat exchanger	*00 Configuration 0 *01 Configuration 1 *02 Configuration 2 *03 Configuration 3 *04 Configuration 4 *05 Configuration 5
US Super tropical unit approved for 46°C ambient	NT NT/NTU NJ NJ						

Accessories configuration	
Code	Description
*00	compressor + base plate + condenser + fan
*01	00 + Rotolock Valves
*02	01 + Liquid Receiver
*03	02 + Electrical box
*04	03 + Filter drier
*05	04 + Sight glass
*06	05 + Fan cover / guard
*07	06 + Pressure switch
*08	07 + Oil Separator
*18	08 + Housing

Condensing Units

Performance Data

R-404A Medium Back Pressure

Product Name	Ambient Temperature (°C)	Cooling Capacity (W)						
		Evaporating Temperature (°C)						
		-20	-15	-10	-5	0	5	10
UNEU6214GK	25	751	915	1084	1259	1439	1625	1814
	32	685	831	983	1142	1306	1476	1652
	43	542	659	783	914	1053	1197	-
UNEU6215GK	25	909	1111	1327	1554	1794	2046	2309
	32	829	1010	1203	1410	1629	1860	2102
	43	694	830	980	1143	1318	1506	-
UNT6222GK	25	1091	1333	1606	1901	2214	2537	2864
	32	990	1212	1461	1731	2015	2307	2601
	43	774	973	1194	1431	1679	1930	-
UNTU6232GK	25	1566	1904	2280	2695	3146	3634	4156
	32	1450	1760	2096	2458	2845	3255	3688
	43	1088	1366	1651	1942	2238	2538	-
UNTU6240GK	25	1943	2420	2884	3334	3769	4185	4581
	32	1779	2196	2609	3015	3413	3801	4178
	43	1462	1857	2259	2668	3081	3497	-

R-404A Low Back Pressure

Product Name	Ambient Temperature (°C)	Cooling Capacity (W)						
		Evaporating Temperature (°C)						
		-40	-35	-30	-25	-20	-15	-10
UNT2212GK	25	808	1061	1329	1617	1926	2260	2621
	32	629	883	1154	1446	1762	2104	2475
	43	509	704	920	1159	1426	1721	-

Condensing Units

Dimensional Data

Product Name	Connections (in)		Dimensions (mm)			Weight (kg)
	Suction	Liquid	Length	Width	Height	
UNEU6214GK	3/8	1/4	465	340	300	22.2
	3/8	1/4	465	340	300	22.2
UNEU6215GK	3/8	3/8	470	395	348	28.5
	3/8	3/8	470	395	348	28.5
UNT6222GK	1/2	3/8	493	395	345	33.2
	1/2	3/8	493	395	345	33.2
UNTU6232GK	5/8	1/2	600	440	372	46.1
	5/8	1/2	600	440	372	46.1
UNTU6240GK	5/8	1/2	600	440	377	51.8
	5/8	1/2	600	440	377	51.8
	5/8	1/2	600	440	377	51.8
UNT2212GK	5/8	3/8	600	440	345	43.3
	5/8	3/8	600	440	345	43.3
	5/8	3/8	600	440	345	43.3

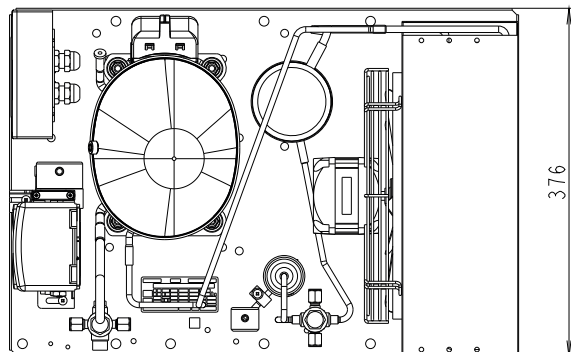
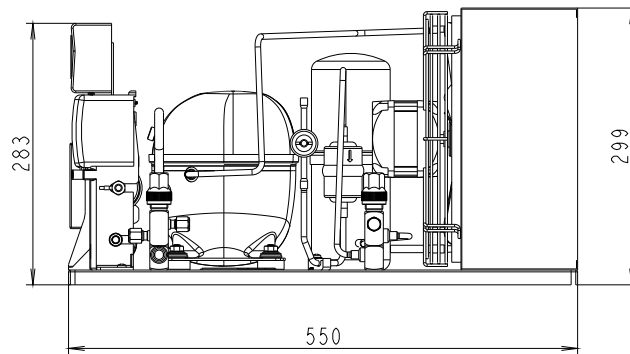

Condensing Units

General Data

R-404A Medium Back Pressure

Product Name	HP	Compressor Model	Displacement (cc)
UNEU6214GK	1/2	NEU6214GK	9,99
UNEU6215GK	3/4	NEU6215GK	12,11
UNT6222GK	1	NT6222GK	17,39
UNTU6232GK	1 1/4	NTU6232GK	20,44
UNTU6240GK	1 1/2	NTU6240GK	27,8
UNT2212GK	1 1/2	NT2212GK	27,8

R-404A Low Back Pressure

Product Name	HP	Compressor Model	Displacement (cc)
UNT2212GK	1 1/2	NJ2212GK	34.38
			34.38
			34.38

Motor Type	Voltage	LRA (A)	Receiver Vol. (L)	Airflow (L/s)
CSIR	220-240 V 50 Hz 1 ph	19.3	1.1	165
CSIR	220-240 V 50 Hz 1 ph	19.3	1.1	165
CSCR	220-240 V 50 Hz 1 ph	21.5	2.3	178
CSCR	220-240 V 50 Hz 1 ph	21.5	2.3	178
CSCR	220-240 V 50 Hz 1 ph	30	2.3	178
CSCR	220-240 V 50 Hz 1 ph	30	2.3	178
CSCR	220-240 V 50 Hz 1 ph	43	3.9	403
CSCR	220-240 V 50 Hz 1 ph	43	3.9	403
CSCR	230 V 50 Hz 1 ph	43	3.9	361
CSCR	230 V 50 Hz 1 ph	43	3.9	361
CSCR	230 V 50 Hz 1 ph	43	3.9	361

Motor Type	Voltage	LRA (A)	Receiver Vol. (L)	Airflow (L/s)
CSCR	220-240 V 50 Hz 1 ph	36	2.3	222
CSCR	220-240 V 50 Hz 1 ph	36	2.3	222
CSCR	220-240 V 50 Hz 1 ph	36	2.3	222

embraco
Nidec

www.embraco.com