

Model

Designation	NL11MF	220-240V/50Hz 1~	Sales code:	105G6156
-------------	---------------	-------------------------	-------------	-----------------

Compressor design

Oil type	Polyolester	Refrigerant(s)	R134a
Oil viscosity	32cST	Displacement	11,15cm ³ / 0,68cu.in
Oil quantity	298cm ³ / 10,1fl.oz	Compressors on pallet	80
Refr. charge - tech. limit	600g / 21,2oz		
Free gas volume comp.	2360cm ³ / 79,8fl.oz		
Weight	10,5kg / 23,1lbs		
Motor protection	1# internal		
Winding resistance main	6,1Ω (at 25°C)		
Winding resistance aux	17,5Ω (at 25°C)		
Max. winding temp.	125°C / 257°F		
Max. discharge temp.	130°C / 266°F		



General - Configurations with NL11MF

	Conf. 1	Conf. 2
Motorconfiguration	CSIR	RSIR
Power supply (nominal)	220-240V/50Hz	220-240V/50Hz
Number of phases	1	1
Voltage range	187-254V	187-254V
Approvals	VDE, CCC, EAC	VDE, CCC, EAC
Starting torque	HST	LST
Note	- / -	

Applications with NL11MF

	Conf. 1	Conf. 2
Refrigerant	R134a	R134a
Application	MBP+HBP	MBP+HBP
System cooling	fan 3m/s	fan 3m/s
Hot gas defrost	OK	OK
Long interval pull down	OK	OK

Electrical data - Configurations with NL11MF

	Conf. 1	Conf. 2
Starting device type	relay	PTC
Run capacitor	-/-	-/-
Start capacitor	125μF	-/-
LRA (locked rotor amps / 4s)	16,6A	13A
RLA (rated load amps / 1s)	2,8A	2,8A
Cut in current	17A	17A

Model

Designation

NL11MF

220-240V/50Hz 1~

Sales code:

105G6156

Compressor dimensions

Housing	A Height	203mm / 7,99in
	B Height	197mm / 7,76in
	C Length shell	205mm / 8,07in
	D Length w. cover	254mm / 10in
	E Width	166mm / 6,54in

Connectors		Suction	Discharge	Process
		X	Y	Z
Diameter	[mm]	øi 8,11-8,29	øi 6,11-6,29	øi 6,11-6,29
	(i:inside, o:outside) [in]	øi 0,32-0,33	øi 0,24-0,25	øi 0,24-0,25
Material		copper	copper	copper
Horizontal angle	±2°	0°	0°	0°
Vertical angle	±2°	15°	35°	155°
Position l/h/w	[mm]	126/76/78	133/103/54	-107/94/72
	[in]	4,9/3/3,1	5,2/4/2,1	-4,2/3,7/2,8
Straight tube l.	[mm]	12	12	12
	[in]	0,5	0,5	0,5

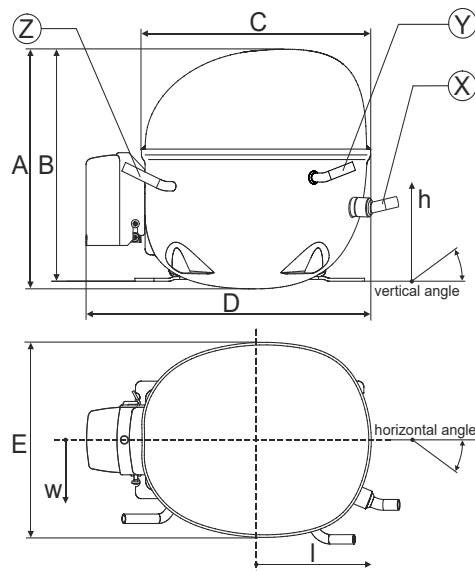

Compressor fixation

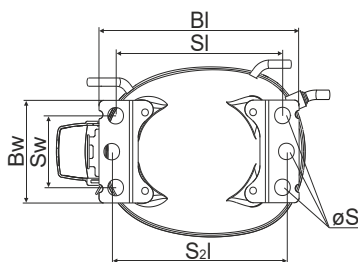

Baseplate	[mm]	[inch]
BI	204	8.03
BW	100	3.94
Small holes		
SI	170	6.7
SW	70	2.76
S1	178	7
øS	ø 16	ø 0.63

Bolt joint

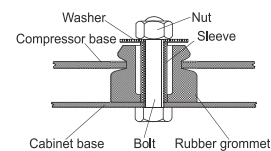

Snap-on

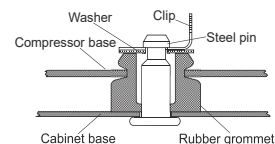

Mounting accessories

	one comp.	multi pack
Bolt joint M6 ø16mm	118-1917	118-1918
Bolt joint ø1/4" ø16mm	118-1946	
Bolt joint ø1/4" ø19mm	118-1949	
Snap-on ø7,3 ø16mm	118-1947	118-1919

Model

Designation	NL11MF	220-240V/50Hz	Conf. 1	Sales code:	105G6156
-------------	---------------	----------------------	----------------	-------------	-----------------

Configuration

Motorconfiguration	CSIR
Power supply (nominal)	220-240V/50Hz 1~
Refrigerant	R134a
Application	MBP+HBP
Voltage range	187-254V
Starting torque	HST
Approvals	VDE CCC EAC

Electrical accessories / wiring diagram

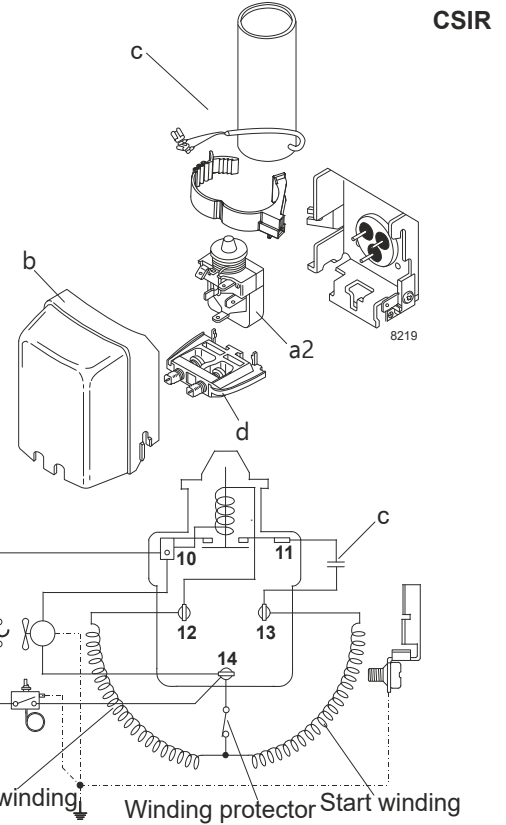

Ambient temperatures / system cooling

Ambient temperature min.:	10°C / 50°F
Ambient temperature max.:	43°C / 110°F

System cooling (n/a: outside limits)			
T ambient	LBP	MBP	HBP
32°C / 90°F	n/a	fan 3m/s	fan 3m/s
38°C / 100°F	n/a	fan 3m/s	fan 3m/s
43°C / 110°F	n/a	fan 3m/s	fan 3m/s

Operation pressure range

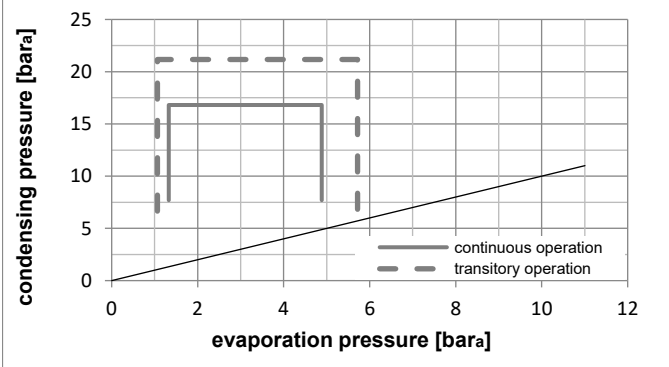
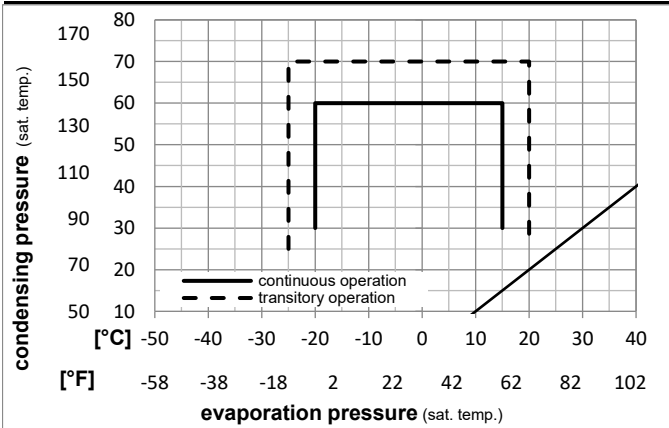

Components

a2	relay	117U6022
c	start capacitor	117U5018
b	plastic cover	103N2011
d	cord relief	103N1010

Model

Designation **NL11MF** **220-240V/50Hz** Conf. 1 Sales code: **105G6156**

Optimization + standard conditions

R134a, 220V/50Hz, CSIR, fan 3m/s, VDE, CCC, EAC

	Evaporating pressure (saturation temperature)				Condensing pressure (saturation temperature)			COP	EER	Power consumption			ASHRAE MBP					
	pe	pc	RGT	Tliq	W	[Btu/h]	[kcal/h]			P1	I	Ref. mass flow						
	[°C]	[°F]	[°C]	[°F]	[W]	[Btu/h]	[kcal/h]	[W/W]	[Btu/Wh]	[kcal/Wh]	[W]	[A]	[kg/h]					
	-7	20	54	130	35	95	46	115	626,5	2140	539,2	1,61	5,51	1,39	388,4	2,46	13,67	ASHRAE MBP
	-10	14	55	131	32	90	55	131	485,0	1656	417,4	1,35	4,60	1,16	360,0	2,37	11,73	cecomaf MBP
	-10	14	45	113	20	68	45	113	546,1	1865	470,0	1,59	5,44	1,37	342,8	2,31	12,78	EN12900 MBP
	-7	20	49	120	18	65	49	120	594,7	2031	511,8	1,58	5,40	1,36	376,3	2,42	14,69	ARI540 MBP
	-10	14	45	113	32	90	45	113	566,6	1935	487,6	1,65	5,64	1,42	342,8	2,31	12,40	opt
	-25	-13	45	113	32	90	45	113	264,5	903	227,6	1,14	3,90	0,98	231,4	2,07	5,73	opt

Performance tables

R134a, 220V/50Hz, CSIR, fan 3m/s, VDE, CCC, EAC

	pe		Cooling capacity			COP	EER	P1	I	m	
	[°C]	[°F]	[W]	[Btu/h]	[kcal/h]	[W/W]	[Btu/Wh]	[kcal/Wh]	[W]	[A]	[kg/h]
[°C / °F]	-20	-4	347,6	1187	299,2	1,30	4,44	1,12	267,5	2,13	7,55
cond. pressure	-15	5	447,5	1528	385,1	1,47	5,01	1,26	304,8	2,21	9,75
pc= 45/113	-10	14	566,6	1935	487,6	1,65	5,64	1,42	342,8	2,31	12,40
return gas temp.	-5	23	707,6	2417	609,0	1,86	6,34	1,60	381,2	2,42	15,56
RGT= 32/90	0	32	873,3	2982	751,6	2,08	7,11	1,79	419,5	2,55	19,31
liquid temp	5	41	1066,2	3641	917,6	2,33	7,96	2,01	457,3	2,70	23,74
Tliq= 45/113	15	59	1544,2	5274	1328,9	2,91	9,95	2,51	529,8	3,03	34,98
[°C / °F]	-20	-4	292,0	997	251,3	1,06	3,63	0,92	274,5	2,14	7,00
cond. pressure	-15	5	380,1	1298	327,1	1,20	4,10	1,03	316,5	2,25	9,15
pc= 55/131	-10	14	485,0	1656	417,4	1,35	4,60	1,16	360,0	2,37	11,73
return gas temp	-5	23	609,3	2081	524,4	1,51	5,15	1,30	404,5	2,51	14,81
RGT= 32/90	0	32	755,7	2581	650,4	1,68	5,74	1,45	449,5	2,67	18,49
liquid temp	5	41	926,8	3165	797,6	1,87	6,40	1,61	494,6	2,84	22,84
Tliq= 55/131	15	59	1353,8	4623	1165,1	2,32	7,92	2,00	583,7	3,23	34,00

Model

Designation	NL11MF	220-240V/50Hz	Conf. 2	Sales code:	105G6156
-------------	---------------	----------------------	----------------	-------------	-----------------

Configuration

Motorconfiguration	RSIR
Power supply (nominal)	220-240V/50Hz 1~
Refrigerant	R134a
Application	MBP+HBP
Voltage range	187-254V
Starting torque	LST
Approvals	VDE
	CCC
	EAC

Electrical accessories / wiring diagram

RSIR

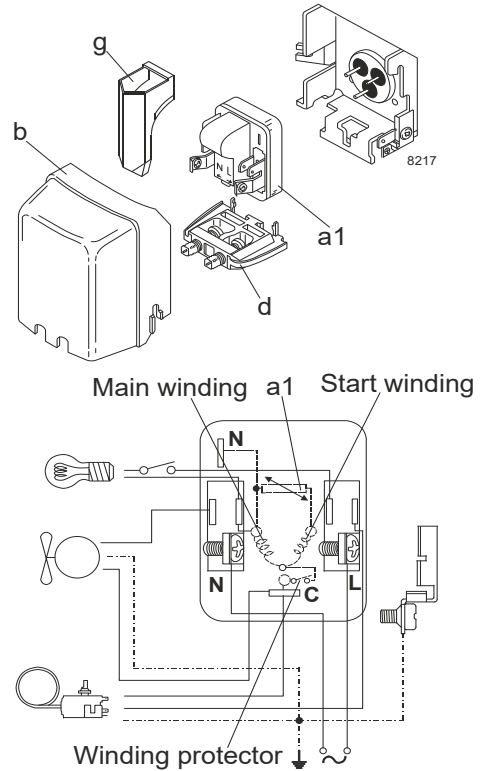

Ambient temperatures / system cooling

Ambient temperature min.:	10°C / 50°F
Ambient temperature max.:	43°C / 110°F

System cooling (n/a: outside limits)			
T ambient	LBP	MBP	HBP
32°C / 90°F	n/a	fan 3m/s	fan 3m/s
38°C / 100°F	n/a	fan 3m/s	fan 3m/s
43°C / 110°F	n/a	fan 3m/s	fan 3m/s

Operation pressure range

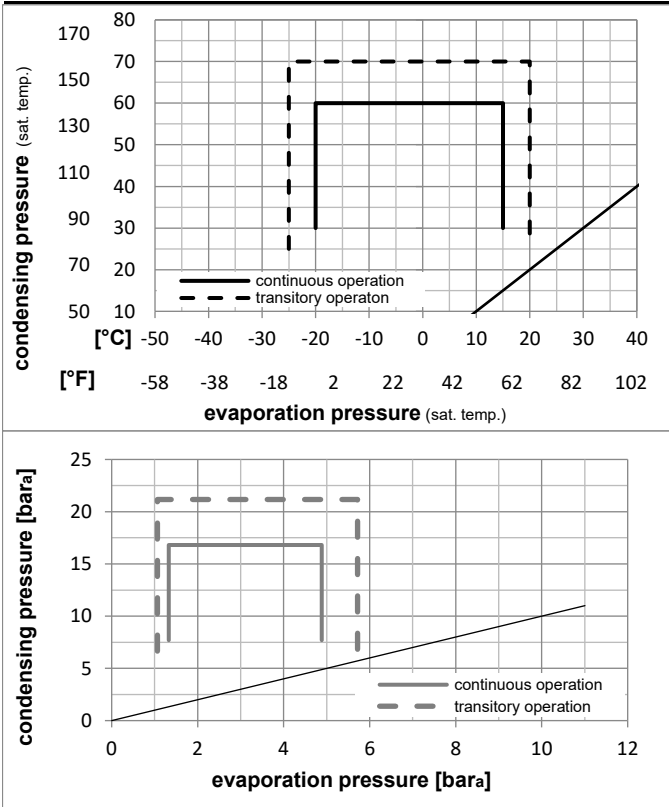

Components

a1	PTC starter (220V, 250hm, 4.8mm)	103N0018
b	plastic cover	103N2011
d	cord relief	103N1010
g	protection screen for PTC	103N0476

Alternative components

a1	PTC starter (220V, 250hm, 6.3mm)	103N0011
b	plastic cover	103N2011
d	cord relief	103N1010
g	protection screen for PTC	103N0476

Model

Designation **NL11MF** **220-240V/50Hz** Conf. 2 Sales code: **105G6156**

Optimization + standard conditions

R134a, 220V/50Hz, RSIR, fan 3m/s, VDE, CCC, EAC

	Evaporating pressure (saturation temperature)				Cooling capacity			COP	EER	Power consumption			ASHRAE MBP	
	pe	pc	RGT	Tliq	[W]	[Btu/h]	[kcal/h]			P1	I	m		
[°C]	-7	54	35	46	626,5	2140	539,2	1,61	5,51	1,39	388,4	2,46	13,67	
[°F]	20	130	95	115										
[°C]	-10	55	32	55	485,0	1656	417,4	1,35	4,60	1,16	360,0	2,37	11,73	cecomaf MBP
[°F]	14	131	90	131										
[°C]	-10	45	20	45	546,1	1865	470,0	1,59	5,44	1,37	342,8	2,31	12,78	EN12900 MBP
[°F]	14	113	68	113										
[°C]	-7	49	18	49	594,7	2031	511,8	1,58	5,40	1,36	376,3	2,42	14,69	ARI540 MBP
[°F]	20	120	65	120										
[°C]	-10	45	32	45	566,6	1935	487,6	1,65	5,64	1,42	342,8	2,31	12,40	opt
[°F]	14	113	90	113										
[°C]	-25	45	32	45	264,5	903	227,6	1,14	3,90	0,98	231,4	2,07	5,73	opt
[°F]	-13	113	90	113										

Performance tables

R134a, 220V/50Hz, RSIR, fan 3m/s, VDE, CCC, EAC

	pe		Cooling capacity			COP	EER	P1	I	m	
	[°C]	[°F]	[W]	[Btu/h]	[kcal/h]						
[°C / °F]	-20	-4	347,6	1187	299,2	1,30	4,44	1,12	267,5	2,13	7,55
cond. pressure	-15	5	447,5	1528	385,1	1,47	5,01	1,26	304,8	2,21	9,75
pc= 45/113	-10	14	566,6	1935	487,6	1,65	5,64	1,42	342,8	2,31	12,40
return gas temp.	-5	23	707,6	2417	609,0	1,86	6,34	1,60	381,2	2,42	15,56
RGT= 32/90	0	32	873,3	2982	751,6	2,08	7,11	1,79	419,5	2,55	19,31
liquid temp	5	41	1066,2	3641	917,6	2,33	7,96	2,01	457,3	2,70	23,74
Tliq= 45/113	15	59	1544,2	5274	1328,9	2,91	9,95	2,51	529,8	3,03	34,98
[°C / °F]	-20	-4	292,0	997	251,3	1,06	3,63	0,92	274,5	2,14	7,00
cond. pressure	-15	5	380,1	1298	327,1	1,20	4,10	1,03	316,5	2,25	9,15
pc= 55/131	-10	14	485,0	1656	417,4	1,35	4,60	1,16	360,0	2,37	11,73
return gas temp	-5	23	609,3	2081	524,4	1,51	5,15	1,30	404,5	2,51	14,81
RGT= 32/90	0	32	755,7	2581	650,4	1,68	5,74	1,45	449,5	2,67	18,49
liquid temp	5	41	926,8	3165	797,6	1,87	6,40	1,61	494,6	2,84	22,84
Tliq= 55/131	15	59	1353,8	4623	1165,1	2,32	7,92	2,00	583,7	3,23	34,00