

STAINLESS STEEL WALL BRACKET



Freddox supplies a wide range of high quality brackets to satisfy various applications for air conditioning outdoor units. Stainless Steel models are suitable for coastal environments.

Features

- Stronger with a more stable structure than most brackets.
- The wall brackets' frame steel sheet is reinforced by precisely stamped profile.
- Delicately designed key structures provides high stability under load.
- Weather-proof with selected SUS304 stainless steel (Including all fixing accessories).
- Adjustable brackets suitable for various installation dimensions and applications.
- Mounting accessories included.

TECHNICAL DATA

PROPERTY	SPECIFICATION
Material	SUS304
Accessories	Anti-vibration assembly, fixing bolts and nuts, expansion bolts with anti-rust treatment

Dimensions (mm)

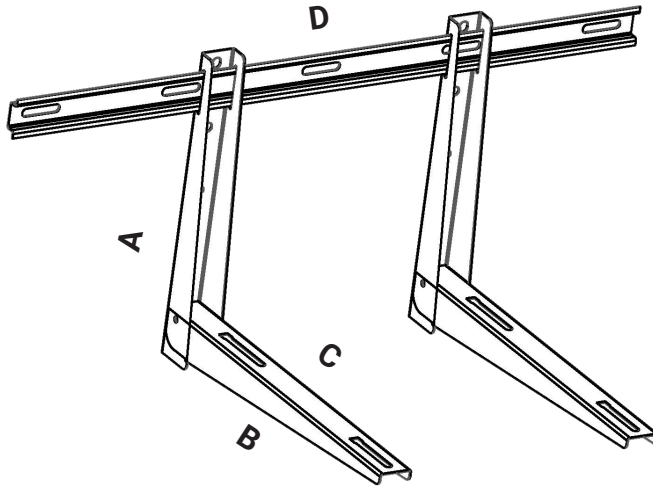

ITEM NO.	A (mm)	B (mm)	C (mm)	D (mm)	STATIC LOAD CAPACITY (kg)
L450STSTK-2	350	450	310	N/A	120
L450ADJBARSTK-2	350	450	310	700	120
L550STSTK-2	450	550	390	N/A	150
L550ADJBARSTK-2	450	550	390	1000	150

FREDDOXSSWALLBRACKET_1222