

POWDER COATED WALL BRACKET

Freddox supplies a wide range of high quality brackets to satisfy various applications for air conditioning outdoor units.

Features

- Stronger with a more stable structure than most brackets.
- The wall brackets' frame steel sheet is reinforced by precisely stamped profile.
- Delicately designed key structures provides high stability under load.
- Weather-proof with special surface treatment (high anti-rust performance).
- Powder coated over electro-galvanized cold rolled steel ideal for outdoor use.
- All steel fixing accessories are specially treated with industrial level anti-rust coating.
- Pre-assembled for easy installation.
- Adjustable brackets suitable for various installation dimensions and applications.
- Mounting accessories included.



TECHNICAL DATA

PROPERTY	SPECIFICATION
Material	Electro-galvanised cold rolled steel
Surface Treatment	Epoxy Resin
Colour	RAL 9002
Accessories	Anti-vibration assembly, fixing bolts and nuts, expansion bolts with anti-rust treatment

Dimensions (mm)

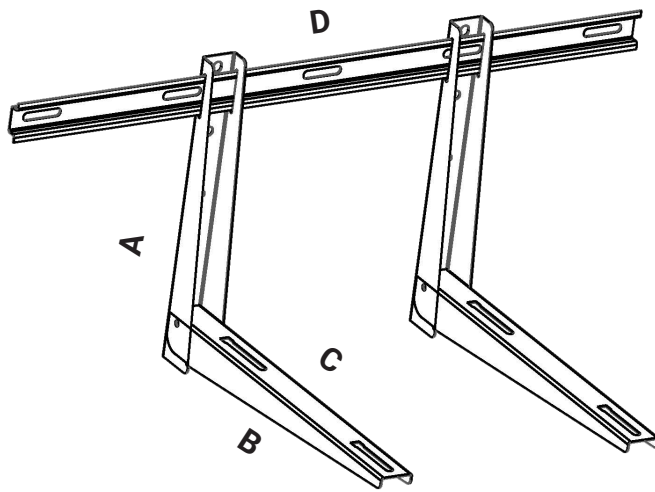

ITEM NO.	A (mm)	B (mm)	C (mm)	D (mm)	STATIC LOAD CAPACITY (kg)
L450K-2	350	450	310	N/A	120
L450ADJBARK-2	350	450	310	700	120
L550K-2	450	550	390	N/A	150
L550ADJBARK-2	450	550	390	1000	150

FREDDOXPCWALLBRACKET_1222