

BLACKMAX®

CPS®

# Premium Tube Bender

BTB300 (IMPERIAL) & BTB300M (METRIC)



## OWNER'S MANUAL (English)

For more information or updates, visit [www.cpsproducts.com](http://www.cpsproducts.com)  
FOR USE BY QUALIFIED PERSONNEL ONLY

# OVERVIEW

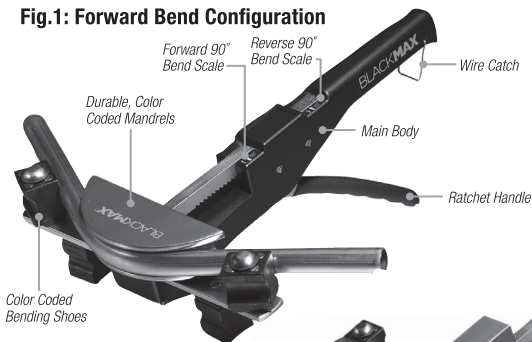
The **BLACKMAX** BTB300 (Imperial) and BTB300M (Metric) are “ratchet crossbow” style tube benders that are ideal for easily bending **soft copper and aluminum tube** up to 90 degrees in both “**FORWARD**” and “**REVERSE**” configurations.

## KEY FEATURES

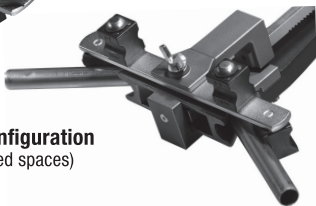
- Seven quick change color coded mandrels for bending for soft copper and aluminum tube
- Make forward or reverse bends, up to 90 degrees
- Graduated forward and reverse 90 degree scale
- Compact, professional, patented design
- Strong molded plastic carrying case

## LAYOUT

**Fig.1: Forward Bend Configuration**



**Fig.2: Reverse Bend Configuration**  
(For making bends in confined spaces)



# GENERAL SAFETY INSTRUCTIONS

- For bending soft copper and aluminum tube only
- NOT for bending steel conduit
- Do not immerse in water or any other liquids
- Do not bend tubing that is under pressure, or that contains gases or liquids
- Always use personal safety equipment (safety glasses, gloves etc.)
- Keep bender dry and lubricate ratchet mechanism as needed
- Do not disassemble this tool or modify it in any way
- For use by qualified personnel only

## SPECIFICATIONS

Mandrels	Solid, color coded aluminum pieces
Ratchet Handle Assembly	Solid, cast and machined aluminum (with quick release steel handle)
Forward & Reverse Bender Attachments	Solid, cast and machined aluminum pieces
Shoe Arms	Chrome plated steel arms with molded, color coded shoes
Storage Case	Molded plastic
Kit Weight	8.4 lb (3.8 kg)
Packaging	Color retail box

## INSTRUCTIONS (FORWARD BENDS)

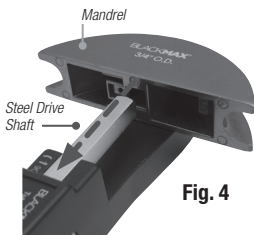
Swing **WIRE CATCH** away from **QUICK RELEASE HANDLE** (Fig. 3).



**Fig. 3**

# INSTRUCTIONS (FORWARD 90° BENDS)

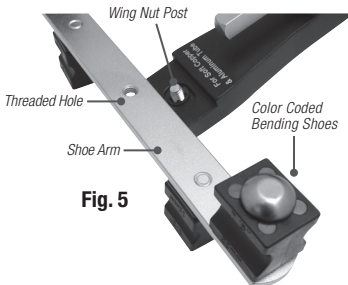
Select **MANDREL** from storage case and attach **END** of **STEEL DRIVE SHAFT** (Fig. 4)



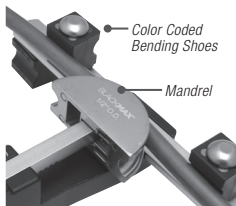
**Fig. 4**

From storage case, select either the 1/4"-3/8" (6-10mm) **SHOE ARM** or 1/2"-7/8" (12-22mm) **SHOE ARM** to match aluminum bender (previously installed).

Attach **SHOE ARM** to **END** of handle assembly using the **WING NUT POST** (Fig. 5). Bending **SHOES** are color coded. Ensure the appropriate size (color) faces **UP** to match the color/size of the bender (Fig 5).

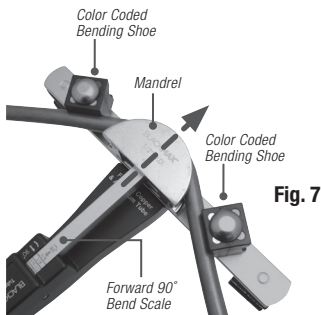


**Fig. 5**



**Fig. 6**

Place soft copper or aluminum tube between end of **MANDREL** and **SHOES** (Fig 6).



**Fig. 7**

# INSTRUCTIONS (FORWARD 90° BENDS)

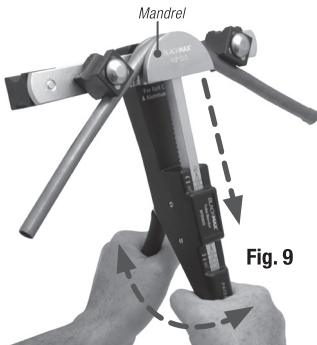
Squeeze **RATCHET HANDLE** until tube is bent to desired angle (Fig 7).

7. To make 90° **FORWARD** Bends -  
Align tube diameter on **DRIVE SHAFT** with **FORWARD MARK** on **HANDLE** (See Fig. 8).  
Check accuracy of bent tube with a square.



**Fig. 8**

8. To remove bent tube, **PULL RATCHET HANDLE** handle away from the **MAIN BODY** of the tool (Fig. 9).
9. Push tube and mandrel toward handle (Fig. 9) then pull tube out of bender

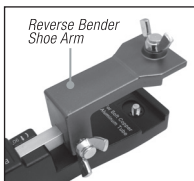


**Fig. 9**

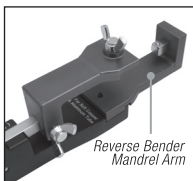
# INSTRUCTIONS (REVERSE 90° BENDS)

In some situations (space constraints), it may be more convenient to use the Reverse Mandrel attachments.

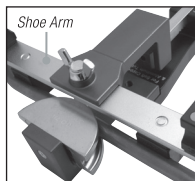
1. Attach **REVERSE MANDREL SHOE ARM** (Fig. 10) and **REVERSE MANDREL** arm (Fig. 11) as shown.
2. Attach aluminum **MANDREL** then small or large **SHOE ARM** to match aluminum bender (Fig. 12).
3. Insert soft copper or aluminum tube and bend to desired angle.



**Fig. 10**



**Fig. 11**



**Fig. 12**

4. To make 90° REVERSE Bends  
- Align tube diameter mark on **DRIVE SHAFT** with **REVERSE MARK** on **HANDLE** (Fig. 13).  
Check accuracy of bent tube with a square.

## REVERSE 90° Bends



**Fig. 13**

## APPENDIX A (REPLACEMENT PARTS)

### BTB300 Tube Bender Kit (Imperial)

Part Number	Description	Mandrel Color
BTBX14	1/4" O.D.	Chrome
BTBX516	5/16" O.D.	Copper
BTBX38	3/8" O.D.	Red
BTBX12	1/2" O.D.	Yellow-Orange
BTBX58	5/8" O.D.	Blue
BTBX34	3/4" O.D.	Green
BTBX78	7/8" O.D.	Red-Violet
BTBXH	Ratchet Tool	
BTBXA1	1/4"-3/8" Shoe Arm	
BTBXA2	1/2"-7/8" Shoe Arm	
BTBXR1	Reverse Bender Mandrel Arm	
BTBXR2	Reverse Bender Shoe Arm	

### BTB300M Tube Bender Kit (Metric)

Part Number	Description	Mandrel Color
BTBX6M	6 mm O.D.	Chrome
BTBX8M	8 mm O.D.	Copper
BTBX10M	10 mm O.D.	Red
BTBX12M	12 mm O.D.	Yellow-Orange
BTBX15M	15 mm O.D.	Blue
BTBX16M	16 mm O.D. (Optional for BTB300M)	Green
BTBX18M	18 mm O.D.	Red-Violet
BTBX22M	22 mm O.D.	
BTBXHM	Ratchet Tool, Metric	
BTBXA1	6-10 mm Shoe Arm	
BTBXA2	12 - 22 mm Shoe Arm	
BTBXR1	Reverse Bender Mandrel Arm	
BTBXR2	Reverse Bender Shoe Arm	

"O.D." = Outside Diameter (of tube)

# WARRANTY

---

CPS Products, Inc. guarantees that all products are free of manufacturing and material defects to the original owner for one year from the date of purchase. If the equipment should fail during the guarantee period it will be repaired or replaced (at our option) at no charge. This guarantee does not apply to equipment that has been altered, misused or solely in need of field service maintenance. All repaired equipment will carry an independent 90 day warranty. This repair policy does not include equipment that is determined to be beyond economical repair.

# LOCATIONS

---

## **CPS PRODUCTS, INC.**

### **U.S.A. (Headquarters)**

1010 East 31st Street,  
Hialeah, Florida 33013, USA  
Tel: 305-687-4121, 1-800-277-3808  
Fax: 305-687-3743

E-mail: [info@cpsproducts.com](mailto:info@cpsproducts.com)

Website: [www.cpsproducts.com](http://www.cpsproducts.com)

## **CPS PRODUCTS CANADA LTD.**

1324 Blundell Road  
Mississauga, ON, L4Y 1M5  
Tel: 905.615.8620, Fax: 905.615.9745  
E-mail: [info@cpsproducts.com](mailto:info@cpsproducts.com)  
Website: [www.cpsproducts.com](http://www.cpsproducts.com)

## **CPS PRODUCTS N.V**

Krijgsbaan 241, 2070  
Zwijndrecht, Belgium  
Tel: (323) 281 30 40,  
E-mail: [info@cpsproducts.be](mailto:info@cpsproducts.be)

## **CPS AUSTRALIA PTY. LTD.**

109 Welland Avenue,  
Welland, South Australia 5007  
Tel: +61 8 8340 7055,  
E-mail: [sales@cpsaustralia.com.au](mailto:sales@cpsaustralia.com.au)

For latest update to this owner's manual, go to [www.cpsproducts.com](http://www.cpsproducts.com)