

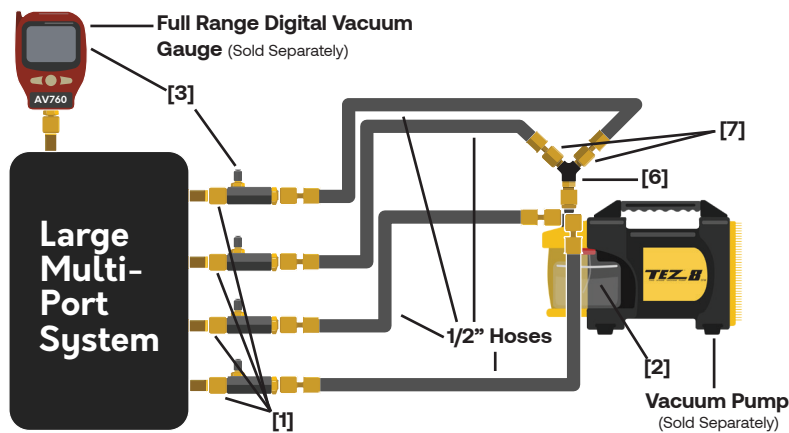

# MegaFlow™ SpeedKit-V

## Quick Start Guide

### How to setup the MegaFlow™ Speed Kit for optimal flow & fast evacuation

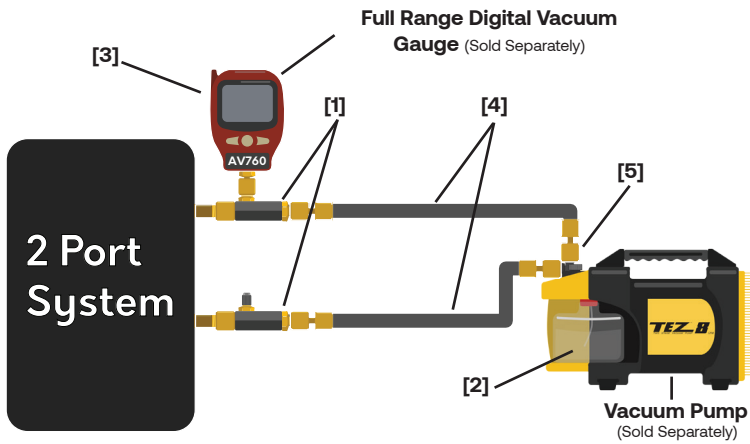

#### Setup Notes - General

- [1] Connect Valve Core Removal Tools to all available ports on the system - Always remove valve cores for full unrestricted flow. (Use Part# MGAVCR for 5/16" port systems)
- [2] Monitor oil condition visually and with a Full Range Digital Vacuum Gauge. Change the oil when the evacuation stalls.
- [3] Connect the vacuum gauge as far from the vacuum pump as possible (on a spare port, or side port of a Valve Core Removal Tool). Vacuum does not equalize like pressure.

#### Setup Notes - 2 Port Systems

- [4] Connect 1/2" hoses for maximum flow.
- [5] It is not necessary to use the Speed-Y on a 2-port system. Connect directly to the Vacuum Pump for best flow.

#### Setup Notes - Multi (3+) Port Systems

- [6] Connect the Appion Speed-Y to the Vacuum Pump for additional connection points.
- [7] Connect additional 1/2" hoses (*sold separately*) to the ports on the Speed-Y

**Note:** Multi-port setups require purchase of additional MegaFlow™ Basics Kits (Part# **MGABAS** (1/4") or **MGABRO** (5/16"))

### Recommended Evacuation Accessories & Products

Product	Description	Part No.
Vacuum Pump	TEZ8 8CFM Vacuum Pump w/ 5 Second Oil Change	TEZ8
Evacuation Hose Kit	MegaFlow™ Basics Kit (Includes Valve Core Removal Tool & 1/2" Vacuum-Rated Hose)	MGABAS (1/4") MGABRO (5/16")
Full Range Vacuum Gauge	AV760 Full Range Wireless Digital Vacuum Gauge	AV760
Vacuum Pump Oil	TEZOM Micron Dry Vacuum Pump Oil	TZM1PK (1 cartridge) TZMGLN (1 Gal.)

### MegaFlow™ Speed Kit Contents

Product	Part No.
(2) MegaFlow™ Valve Core Removal Tools (1/4")	MGAVCT
(2) MegaFlow™ Valve Core Removal Tools (5/16")	MGAVCR
(2) 1/2" Vacuum-Rated Hoses (Black)	MH120006EAK
(2) Appion Speed-Ys 3/8" <b>Universal</b> & 1/2" <b>TEZ8</b>	SPDY38 (3/8") SPDY12 (1/2")
(1) Speed Kit Carry Bag (Backpack)	PK7520

See Reverse for Important Evacuation Tips

# Important Evacuation Tips

- **Remove valve cores before evacuation** - Valve Cores & Core Depressors block up to **90%** of all flow and will limit the flow of any vacuum pump to  $\approx 0.2$  CFM. **[Fig. 1]**
- **Use as many 1/2" vacuum-rated hoses during evacuation as possible**- Larger hoses have greater flow and will result in faster evacuation when used correctly.
- **Connect hoses directly\* to the Vacuum Pump** - Direct connections to the pump have better flow and less chance to leak compared to being connected to a manifold. *\*Except in cases of multi-port systems, see reverse*
- **Monitor condition of the oil during evacuation** - Vacuum pump oil is one of the biggest influences on the speed of an evacuation. Clean oil will allow the system to be evacuated to a much deeper vacuum than contaminated oil. Stalled evacuations are often the result of dirty, contaminated oil. A vacuum pump can only pull a vacuum as deep as the vapor pressure of its sealing oil. As the oil collects contaminants & moisture during evacuation, this vapor pressure rises. Clean oil restores vacuum pump efficiency & can save hours or days on an evacuation. Oil should be changed early & as needed for fast evacuation. **[Fig. 2] This could be multiple times on one job!**
- **Use a Digital Vacuum Gauge to monitor progress** - The only way to verify a complete evacuation is with a digital vacuum gauge. A Full Range gauge is recommended for complete visibility.
- **Connect the Vacuum Gauge to the system as far from the pump as possible** - For a system to be adequately dehydrated a deep vacuum must be achieved throughout the entire system, not just the point where the vacuum pump is connected. Unlike pressure, vacuum will not quickly equalize across all points of the system. For the most accurate reading of vacuum depth throughout the system, connect the vacuum gauge at an access port on the system that is farthest from the Vacuum Pump. **[Fig. 3]** It is possible for one end of the system to be evacuated to 1,000 microns while another end - far from the vacuum pump - can still be at 10,000 microns.
- **Do Not use 1/4" hoses & charging manifolds for evacuation** - A standard 1/4" hose & manifold are not meant for evacuation and will limit the flow of any vacuum pump to  $\approx 1$  CFM (w/ valve core removed). **[Fig. 4]**
- **Do Not run the Vacuum Pump for multiple jobs without changing the oil** - Dirty oil = slow evacuation and can damage the pump. Oil should be changed when needed!
- **Do Not tighten hoses & port caps with tools** - Gaskets can be damaged if overtightened, creating a leak. Hand tight only!

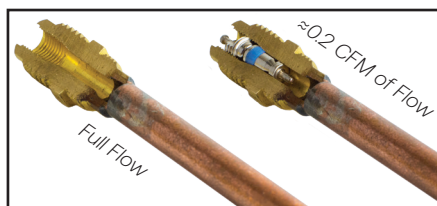

**[Fig. 1]** Access Port Cutaway

6ft, 1/4" hose through valve core	40 Min	$\approx 0.2$ CFM
6ft, 1/4" hose with core removed	19 Min	$\approx 1$ CFM
6ft, 1/2" hose with core removed	3 Min	$\approx 3$ CFM

**[Fig. 4]** Evacuating 10-ton system to 500 Microns

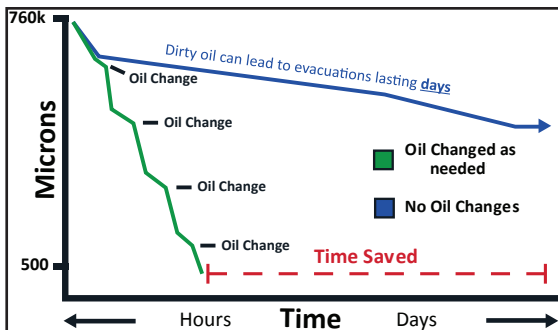

**[Fig. 2]** Time savings of changing vacuum pump oil during a job

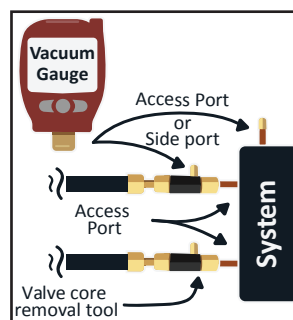

**[Fig. 3]** Correct Vacuum Gauge Placement

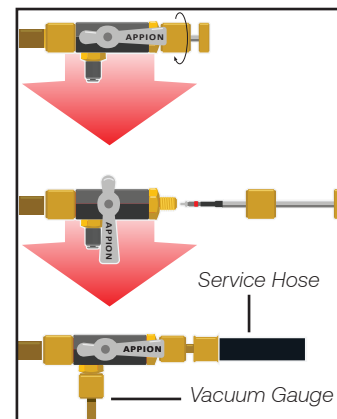

**[Fig. 5]** Valve Core Removal Tool Usage



Sales@AppionTools.com  
 Support@AppionTools.com  
 303-937-1580  
 www.AppionTools.com  
 Appion Inc., Englewood, CO, USA