

Data sheet

# Fan speed controller

## Type Saginomiya RGE



Fan speed controller RGE stabilizes condensing pressure by changing condenser's fan speed.

Widespread usage in refrigeration and air conditioning units which are operated throughout the entire year.

Reliable sensing mechanism using bellows.

Suitable for single phase and 3-phase fan motors.

### Features

- Wide regulating range
- Easy setting and adjusting
- Simple and easy electrical connection
- Multiple fans control
- Minimum speed and cut-off working modes
- Weather-proof enclosure (IP54)

### Approvals

CE in accordance to EMC and LVD directives,  
UL (only selected models)

**Function**

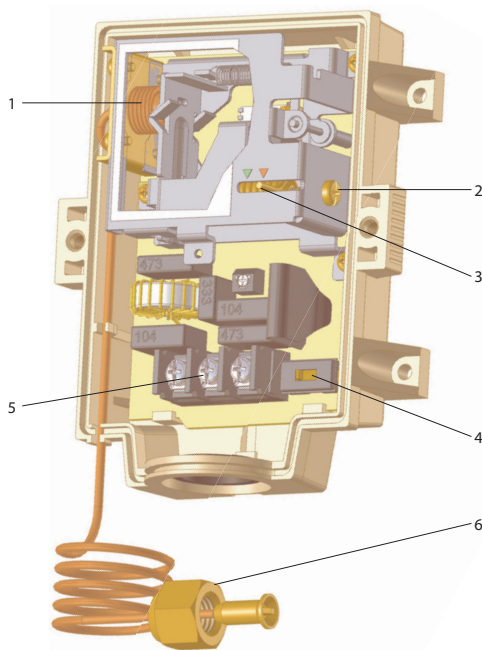

1. Adjusting screw
2. Bellows
3. Range setting pointer (dual marking 11 and 19bar)
4. Change over switch
5. Terminal board
6. 1/4" flare with depression pin (7/16-20 UNF)

**Setting point** is increased by turning the range adjusting screw clockwise. It is decreased by turning the screw counter clockwise. Adjustment should be within the range indicated for the setting pointer.

**Cut off:** Fan motor stops when the pressure decreases below the value P<sub>min</sub>.

**Min. Speed:** Fan motor operates at the Minimum Speed when the pressure decreases below the value P<sub>min</sub>.

F.V.S = Full Voltage Set Point (pressure setting for maximum speed)

E.P.B = Effective Proportional Band

$$P_{min} = (F.V.S - E.P.B)$$

The RGE controls the speed of the condenser fan in refrigeration and air conditioning units that work all year long.

It keeps the condensing pressure at a steady level by changing the speed of the fan according to the required condensing pressure.

**Technical data**

**3A single-phase type**

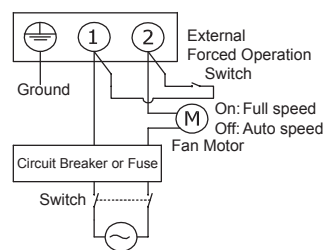

- 2 terminals
- External forced operation switch

**4A, 6A, 8A single-phase type**

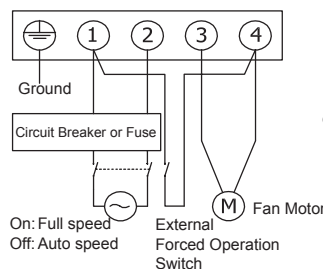

- 4 terminals
- External forced operation switch

**Three-phase type**

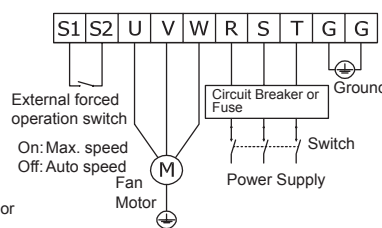

- 8 terminals
- External forced operation switch

**On** - fan is forced to operate at Maximum speed regardless of the pressure.  
**Off** - fan operates according to the RGE function, with speed varying according to pressure.

connecting cables (not supplied) should have current rating higher than the fan motor rating. For example, a 4A switch is recommended for the 3A RGE model.

For single-phase type, if an external forced operation switch is required, then the switch and

For three-phase type, use a forced operation switch with non-voltage contact signal.

**Single-phase type**

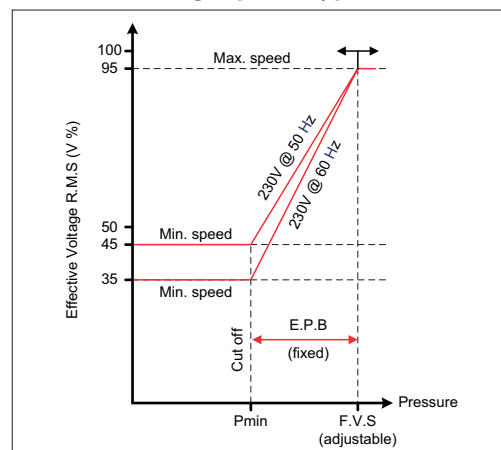

The operating characteristics may vary according to voltage, frequency and fan motor characteristics

**Three-phase type**

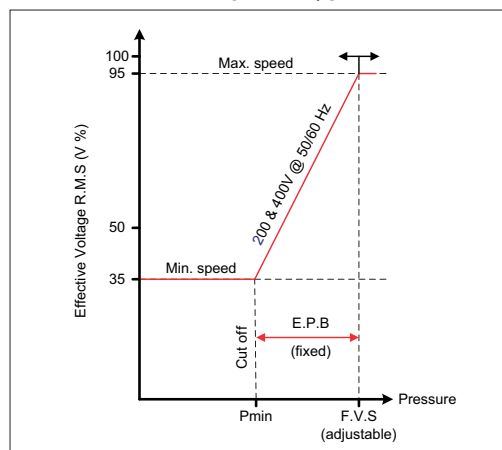

**Application example**

The pressure connection of the RGE can be made either before or after the condenser providing more installation options and flexibility.

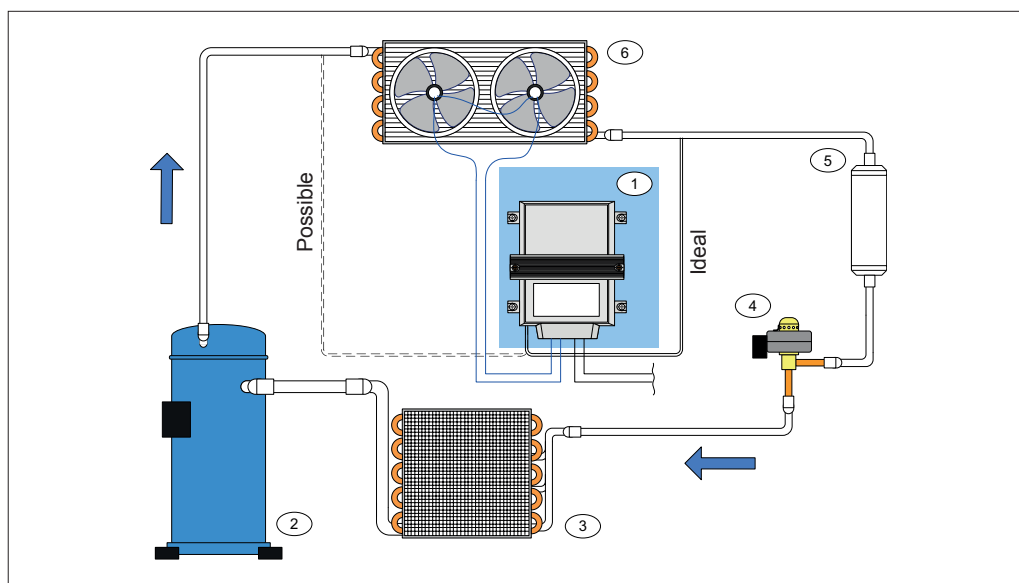

- 1. RGE Fan Speed Controller
- 2. Compressor
- 3. Evaporator
- 4. Expansion valve
- 5. Receiver
- 6. Condenser

Fig. Typical refrigeration system using RGE fan speed controller

**Technical data**

**Single-phase versions 3-8 A**

For R22, R134a, R404A, R407A, R407C, R407F, R410A\*, R448A, R449A, R452A, R513A, R450A

Type	Factory set	Adjusting range	Proportional band	Operational range	Electrical motor rating	Power supply	Ambient temp.	Code no
	[bar]	[bar]	[bar]	[bar]	[A]		[°C]	
RGE-Z1L4-7DS	19	8 – 28	6	2 – 28	0.2 – 3	200 – 240 V 50/60 Hz	-20 – 55	061H3045
RGE-Z1L6-7DS	32	16 – 39	9	7 – 39	0.2 – 3	200 – 240 V 50/60 Hz	-20 – 55	061H3048
RGE-Z1N4-7DS	19	8 – 28	4	4 – 28	0.2 – 4	200 – 240 V 50/60 Hz	-20 – 55	061H3005
RGE-Z1N6-7DS	32	16 – 39	8	8 – 39	0.2 – 4	200 – 240 V 50/60 Hz	-20 – 55	061H3021
RGE-Z1P4-7DS	19	8 – 28	4	4 – 28	0.2 – 6	200 – 240 V 50/60 Hz	-20 – 55	061H3008
RGE-Z1P6-7DS	32	16 – 39	8	8 – 39	0.2 – 6	200 – 240 V 50/60 Hz	-20 – 55	061H3022
RGE-Z1Q4-7DS	19	8 – 28	4	4 – 28	0.2 – 8	200 – 240 V 50/60 Hz	-20 – 55	061H3009
RGE-Z1Q6-7DS	32	16 – 39	8	8 – 39	0.2 – 8	200 – 240 V 50/60 Hz	-20 – 55	061H3023

Single-phase version: cut-off or minimum speed function selectable with changeover switch at approx. 45% of the maximum effective output for 50Hz and 35 % for 60Hz.

\*) for RGE-Z1L6-7DS, RGE-Z1N6-7DS, RGE-Z1P6-7DS, RGE-Z1Q6-7DS

**Three-phase versions 5-7 A**

For R22, R134a, R404A, R407A, R407C, R407F, R410A\*, R448A, R449A, R452A, R513A, R450A

Type	Factory set	Adjusting range	Proportional band	Operational range	Electrical motor rating	Power supply	Ambient temp.	Code no
	[bar]	[bar]	[bar]	[bar]	[A]		[°C]	
RGE-Z3R4-7DS	16	8 – 28	4	8 – 28	0.2 – 5	200 – 240 V 50/60 Hz	-20 – 50	061H3003
RGE-X3R4-7DS	16	8 – 28	4	4 – 28	0.2 – 5	380 – 415 V 50/60 Hz	-15 – 50	061H3006
RGE-X3R6-7DS	32	16 – 39	8	8 – 39	0.2 – 5	380 – 415 V 50/60 Hz	-15 – 50	061H3028
RGE-Z3T4-7DS	16	8 – 28	6	2 – 28	0.2 – 7	200 – 240 V 50/60 Hz	-20 – 50	061H3050

Three-phase version: cut-off or minimum speed function selectable with changeover switch at approx. 35% of the maximum effective output.

\*) for RGE-X3R6-7DS

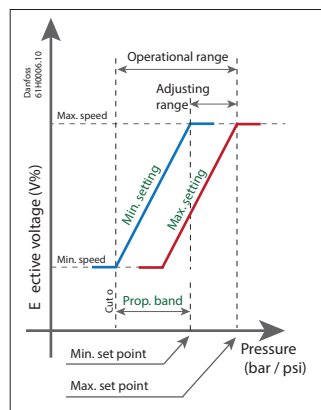

All cased models of RGE are weather-proof (IP54 protection rating) and are suitable for exterior installation.

For all types max. working pressure is 47 bar.

Dimensions

Single-phase versions

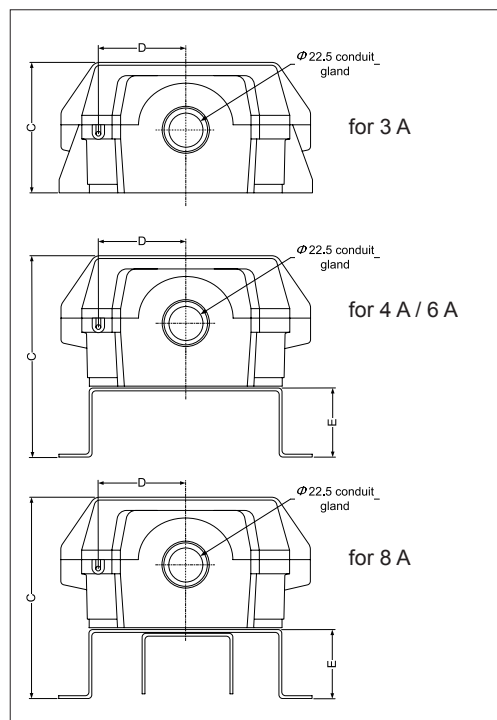
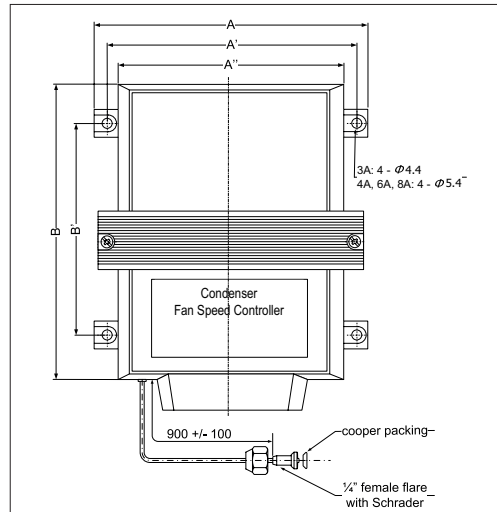

Three-phase versions

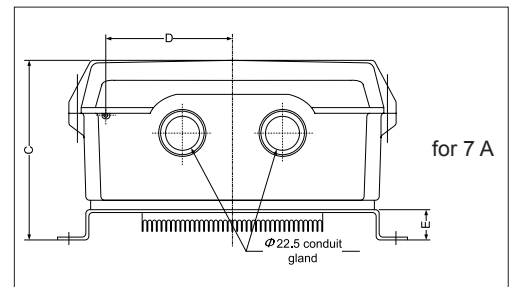
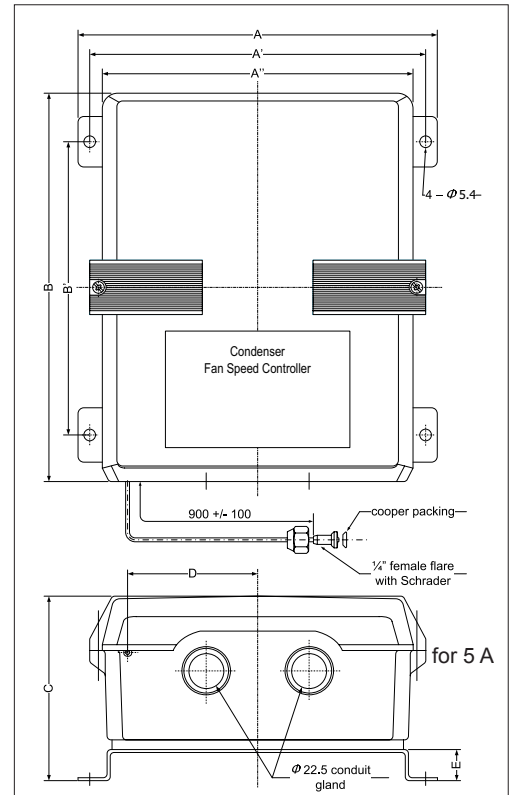

Dimensions	Single-phase version				Three-phase version	
	3 A	4 A	6 A	8 A	5 A	7 A
A	104	105	105	105	185	185
A'	95	95	95	95	175	175
A''	85	85	85	85	160	160
B	125	150	150	150	200	200
B'	75	100	100	100	130	130
C	55	58	76	76	98	98
D	36	36	36	36	67	67
E	-	7	25	25	16	16

Danfoss can accept no responsibility for possible errors in catalogues, brochures and other printed material. Danfoss reserves the right to alter its products without notice. This also applies to products already on order provided that such alterations can be made without subsequent changes being necessary in specifications already agreed. All trademarks in this material are property of the respective companies. Danfoss and the Danfoss logotype are trademarks of Danfoss A/S. All rights reserved.