

# TACm/PSB30: 30 HOUR BATTERY BACKUP SYSTEM

## FEATURES

- 30 hour backup operation for a TACm.
- Indicator LEDs for mains power (Red), 12vdc output (Green) and unit charging output (yellow).
- Load is automatically disconnected when battery is flat to avoid battery damage.
- Protection against short circuit and reverse polarity battery of connections.



## OPERATION

The TACm/PSB30 is a 12V system incorporating a high capacity battery. It is suitable for the following Phasefale products, TACm, TC1, DPM02D, Presscon Network, AD2, Vat Pac, PowerMiser etc. Up to 4 TACm's can be backed up by the one TACm/PSB30.

## STORAGE AND SHIPPING

The TACm/PSB30 is shipped with the battery lead disconnected. Reconnect this before operating the unit. If the TACm/PSB30 is to be disconnected from the mains for more than a few days, disconnect the battery from the unit until it is used again. This will prolong the life of the battery.

## WARNING

Do not operate the TACm/PSB30 with the battery disconnected, damage caused by this will not be covered by warranty.

## INSTALLATION

Ensure the AC input is off before working with the unit.

First connect the standby battery to the leads provided (red=Positive). Press the reset switch to connect the power to the battery. If the unit does not maintain power, the battery voltage is below use and should be replaced. Close up the unit and switch the AC input on.

The unit will supply a constant voltage to the output contacts as specified. In the event of a short circuit to the output, the unit will drop the voltage until the fault is corrected, and immediately reset the voltage thereafter. The same applies when exceeding the current specification.

The standby battery is monitored for low voltage. The battery is disconnected by the unit in the event of it being below 10.8VDC, and reconnected with the presence of the input of AC power.

To test the working unit, switch off the AC Input voltage and observe it runs correctly from the Standby battery. Restore the AC Input after test.

## MAINTENANCE

The battery and circuitry are maintenance free.

The life of the battery will depend on the number of times battery backup is required and the amount of discharge which occurs. The battery should be checked annually by turning off the mains supply and ensuring the equipment continues to operate for a suitable period.

## WIRING DIAGRAM

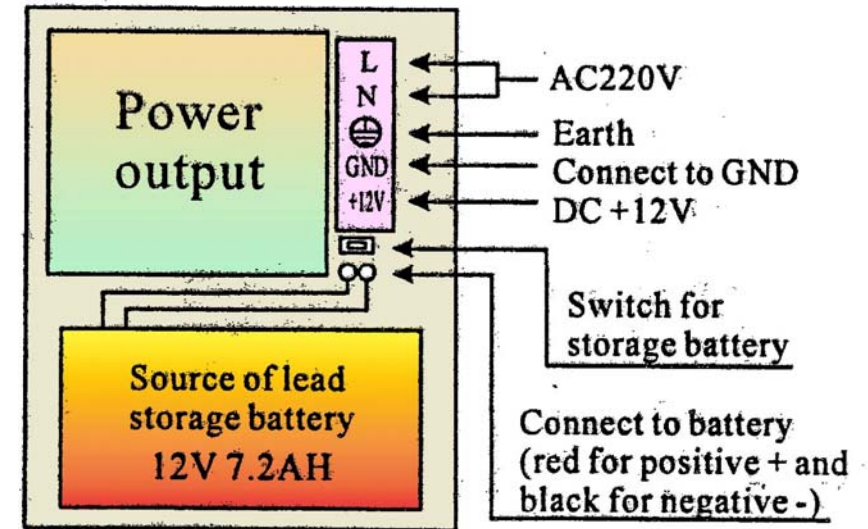

## SPECIFICATIONS

Mains Supply	240 +/- 10% VAC
Battery Capacity	7 Amp Hour
Charging Rate	500 mA
Nominal Output Voltage	12 Volt DC
Battery Charge Voltage *	14.0 Volts
Battery Float Voltage *	13.5 Volts
Battery Low Voltage Cutout *	10.5 Volts
Mains On/Off Relay Contacts	240 VAC 1 Amp Resistive load
Max. Load Current (Battery Charging)	250 mA
Max. Load Current (Mains Off)	2 Amps

\* The above values are temperature compensated and will vary with ambient temperature. All specifications are subject to change without notice.

**Phasefale Pty. Ltd.** ACN 078 932 448  
36 Bulli Street Moorabbin VIC 3189 AUSTRALIA  
Phone +613 9553 0800 Fax +613 9553 3993  
[www.phasefale.com.au](http://www.phasefale.com.au) [sales@phasefale.com.au](mailto:sales@phasefale.com.au)