

NOTICE TECHNIQUE D'INSTALLATION INSTALLATION INSTRUCTIONS INSTALLATIONSNOTIZ MANUAL TECNICO DE INSTALACION

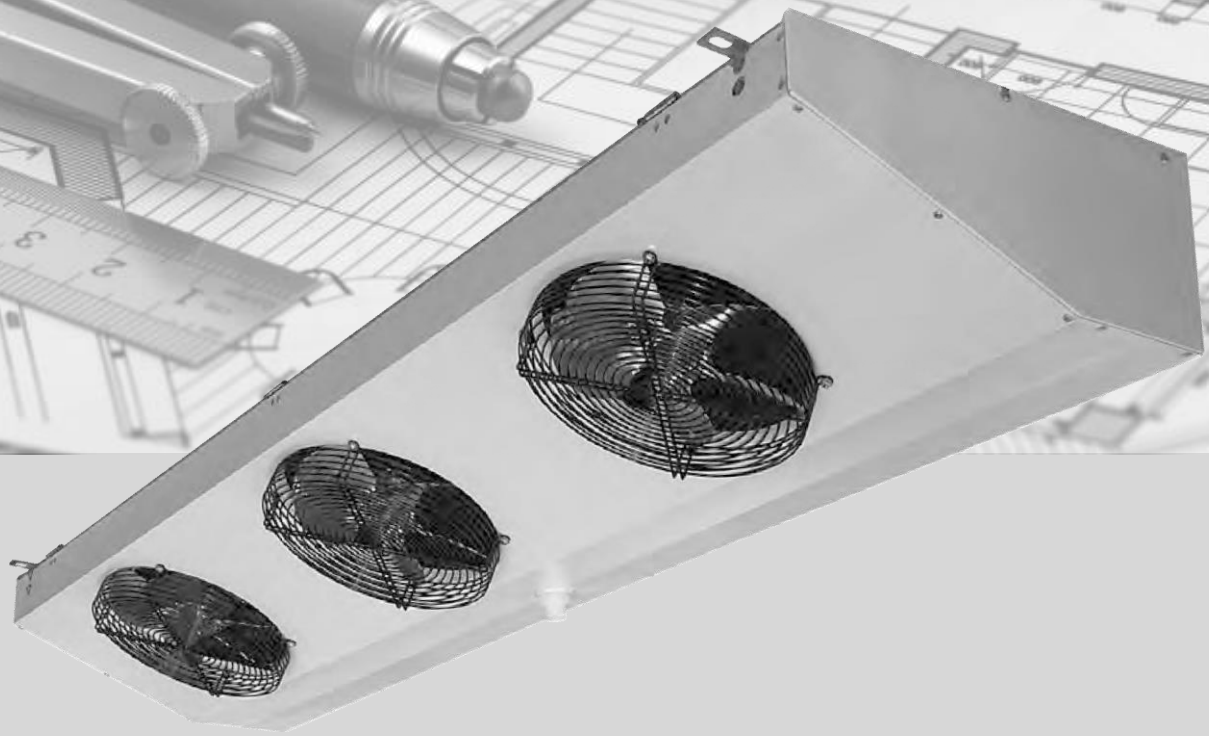

Unit Coolers

MH

N° IN0016300-E
09.2021

**1 . OUVERTURE CARROSSERIE ET MONTAGE TUBE ECOULEMENT
 CASING OPENING AND DRAIN FITTING ASSEMBLY
 GEHÄUSE ÖFFNEN UND INSTALLATION DES ABLAUFROHRS
 ABERTURA DE CARROCIERÍA Y MONTAJE DEL TUBO DE DESAGÜE**

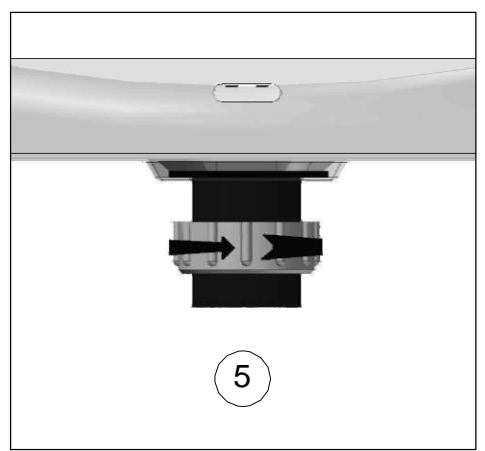
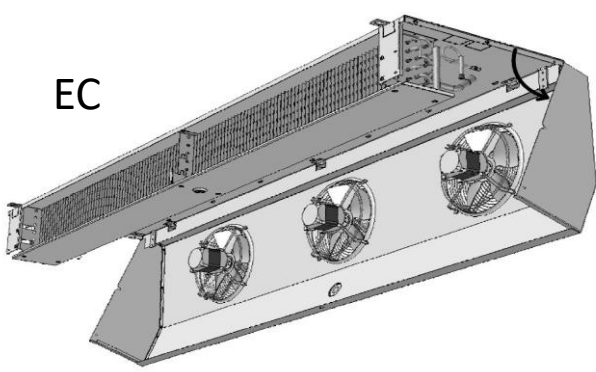
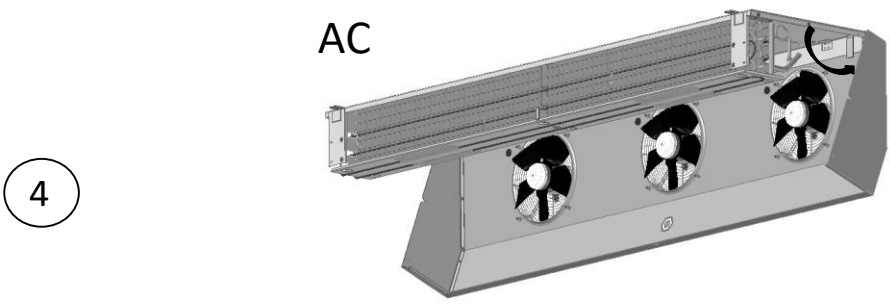
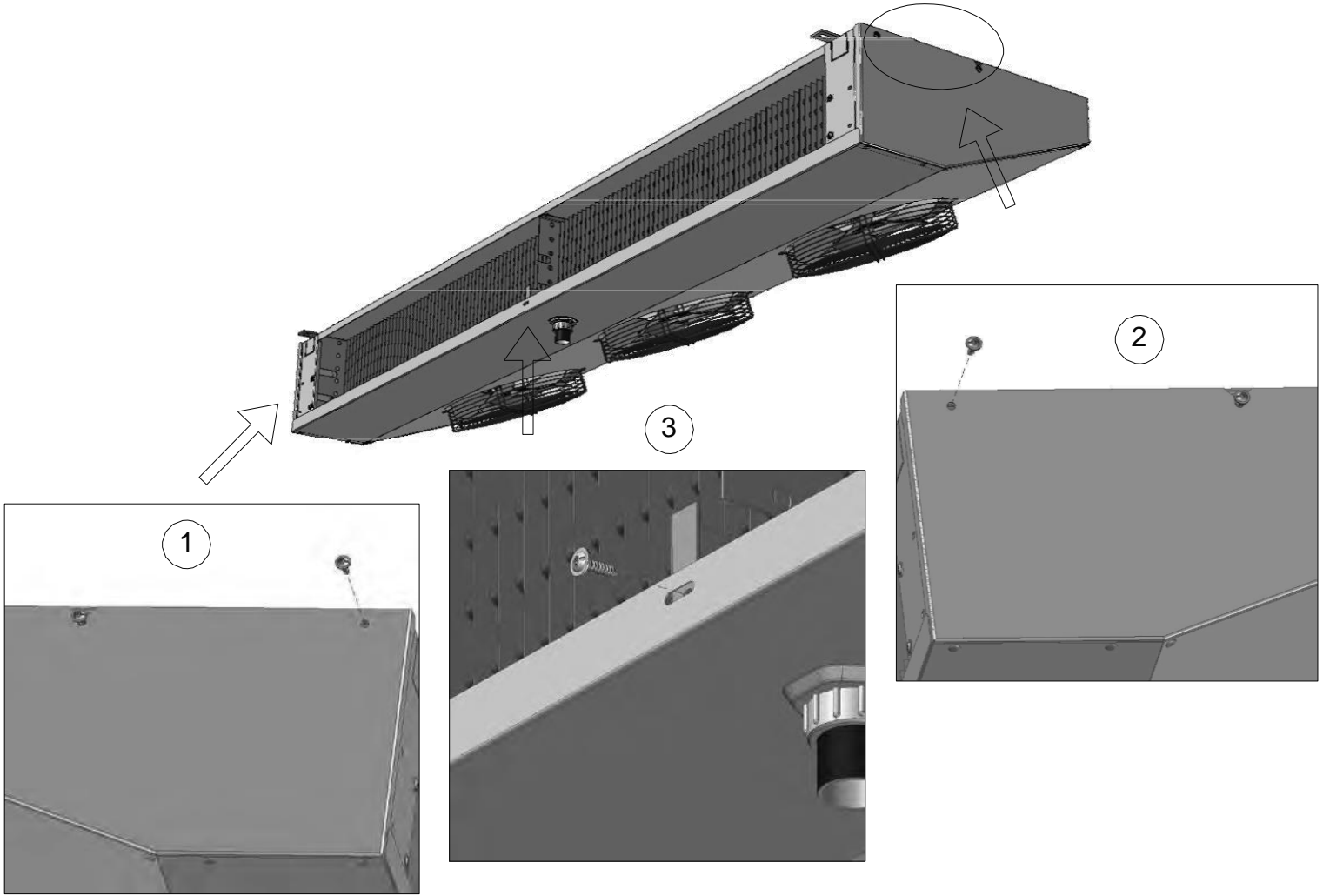
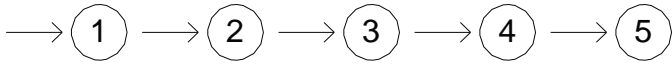

2 . MONTAGE EVAPORATEUR ET CONDUITES
UNIT COOLER FIXING AND PIPING
INSTALLATION DES VERDAMPFERS UND DER LEITUNGEN
MONTAJE EVAPORADOR Y TUBERÍA

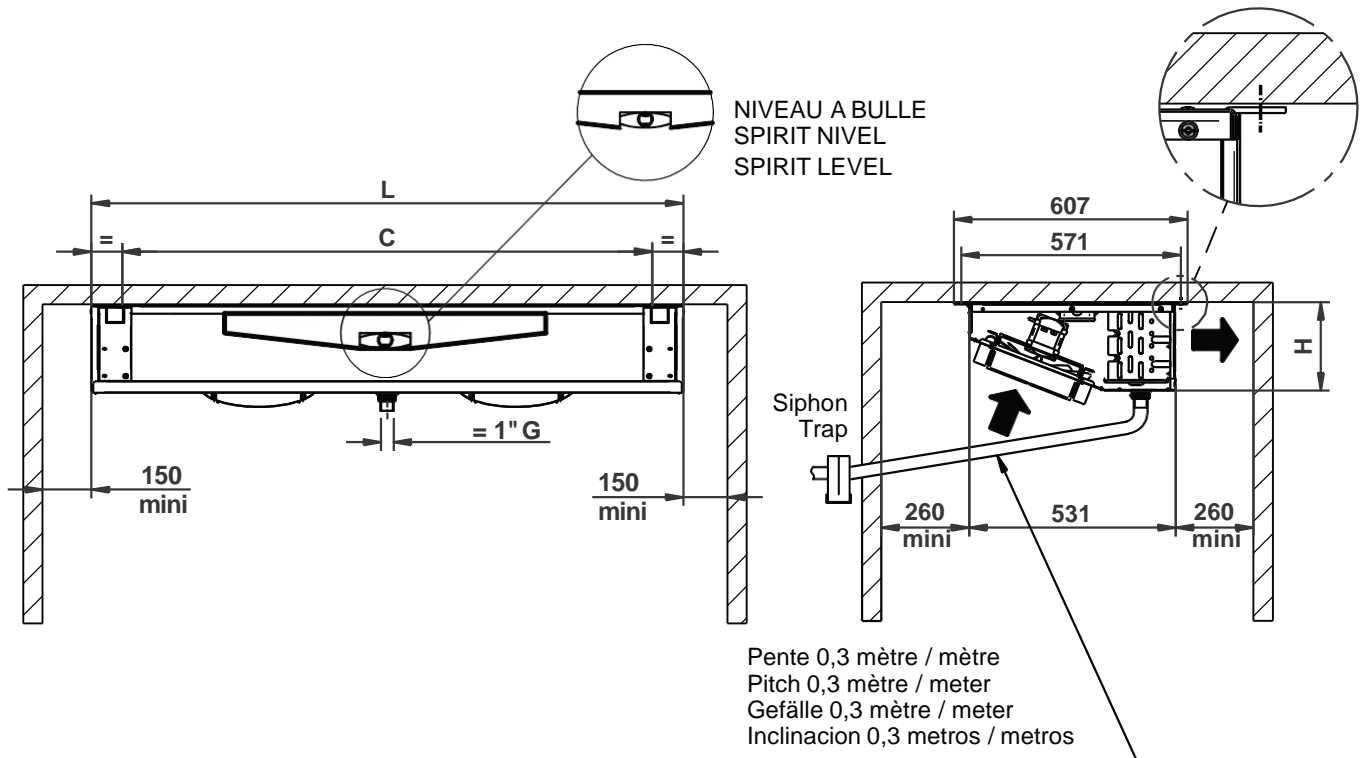

	MH320R MHE320E MH250L MHE250C	MH380R MHE380E MH310L MHE310C	MH460R MHE460E MH370L MHE370C	MH550R MHE550E MH450L MHE450C	MH640R MHE640E MH510L MHE510C	MH770R MHE770E MH630L MHE630C
L	1531	1531	2197	2197	2499	2499
C	1372	1372	2038	2038	2340	2340
H	228	228	228	228	260	260

FIXATION AU PLAFOND - FITTING TO CEILING
DECKENBEFESTIGUNG - FIJACION EN EL TECHO

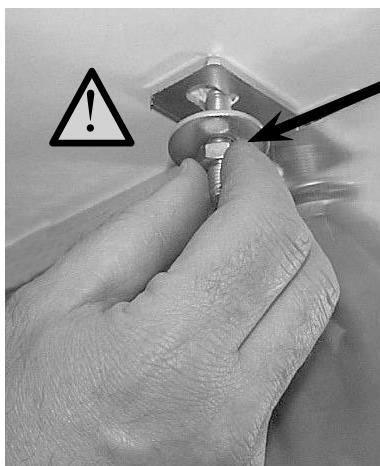

Ø 10

Ecrous de sécurité Safety
nuts Sicherungsmuttern
Tuercas de seguridad



Les supports de fixation doivent être plaqués au plafond
The mounting brackets must be tightened against the ceiling surface Soportes
de montaje estrictamente para techo
Die halterung müssen dicht an der decke

3 . RACCORDEMENTS ELECTRIQUES - Standard ELECTRICAL CONNECTIONS - Standard ELEKTRISCHE ANSCHLÜSSE - Standard CONEXIONES ELECTRICAS - Estándar

		MH320R MH380R MH250L MH310L	MHE320E MHE380E MHE250C MHE310C	MH460R MH550R MH370L MH450L	MHE460E MHE550E MHE370C MHE450C	MH640R MH770R MH510L MH630L	MHE640E MHE770E MHE510C MHE630C
	W	148	148	222	222	296	296
	A 230/1/50Hz	0,68	0,68	1,02	1,02	1,36	1,36
	W		1800		2700		3600
	A 230/1/50Hz		7.8 *		11,7		15,7
	A 400/3/50Hz				3.9 *		5.2 *

Option : RE résistance tube d'écoulement 50 W/m - Optional: RE drain line heater 50 W/m
Option: RE Ablaufheizung 50 W/m - Opción: RE resistencia tubo de desagüe 50 W/m

* Montage usine - Factory mounted - Werkseitig montiert- Montadas en fábrica

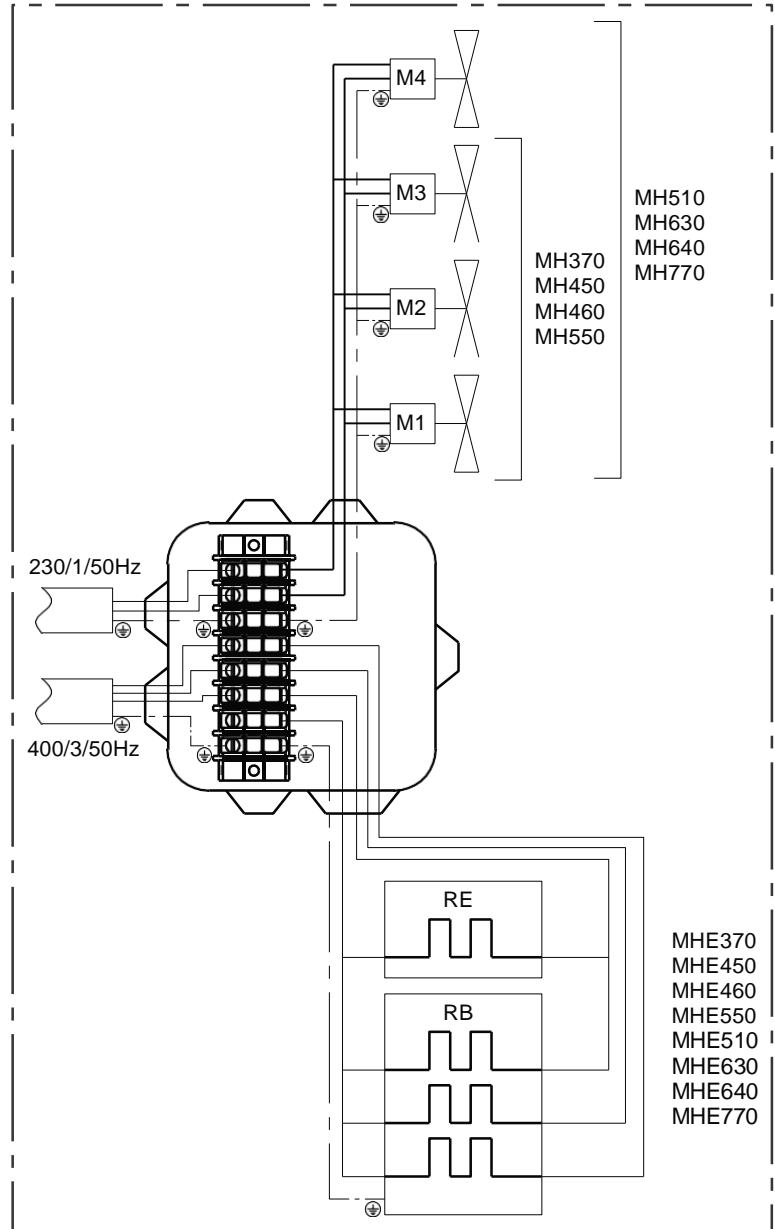
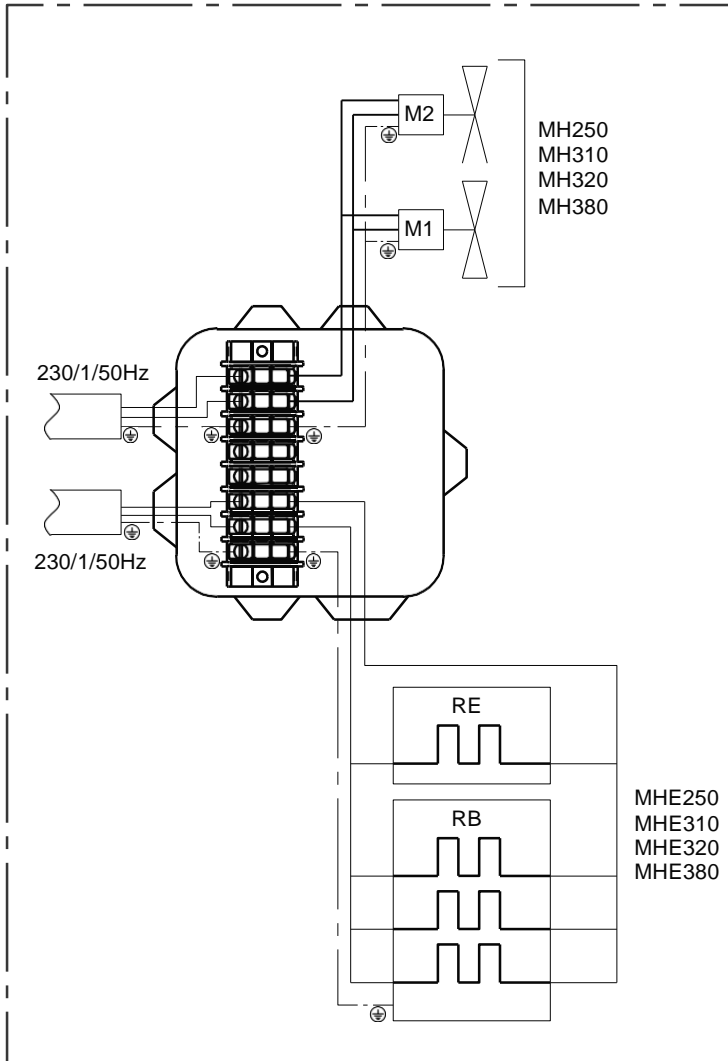

4 . RACCORDEMENTS ELECTRIQUES - Option EC
ELECTRICAL CONNECTIONS - EC option
ELEKTRISCHE ANSCHLÜSSE - EC-Option
CONEXIONES ELECTRICAS - Opción EC

		MH320R MH380R MH250L MH310L	MHE320E MHE380E MHE250C MHE310C	MH460R MH550R MH370L MH450L	MHE460E MHE550E MHE370C MHE450C	MH640R MH770R MH510L MH630L	MHE640E MHE770E MHE510C MHE630C
	W	80	80	120	120	160	160
	A 230/1/50Hz	0,50	0,50	0,75	0,75	1,00	1,00

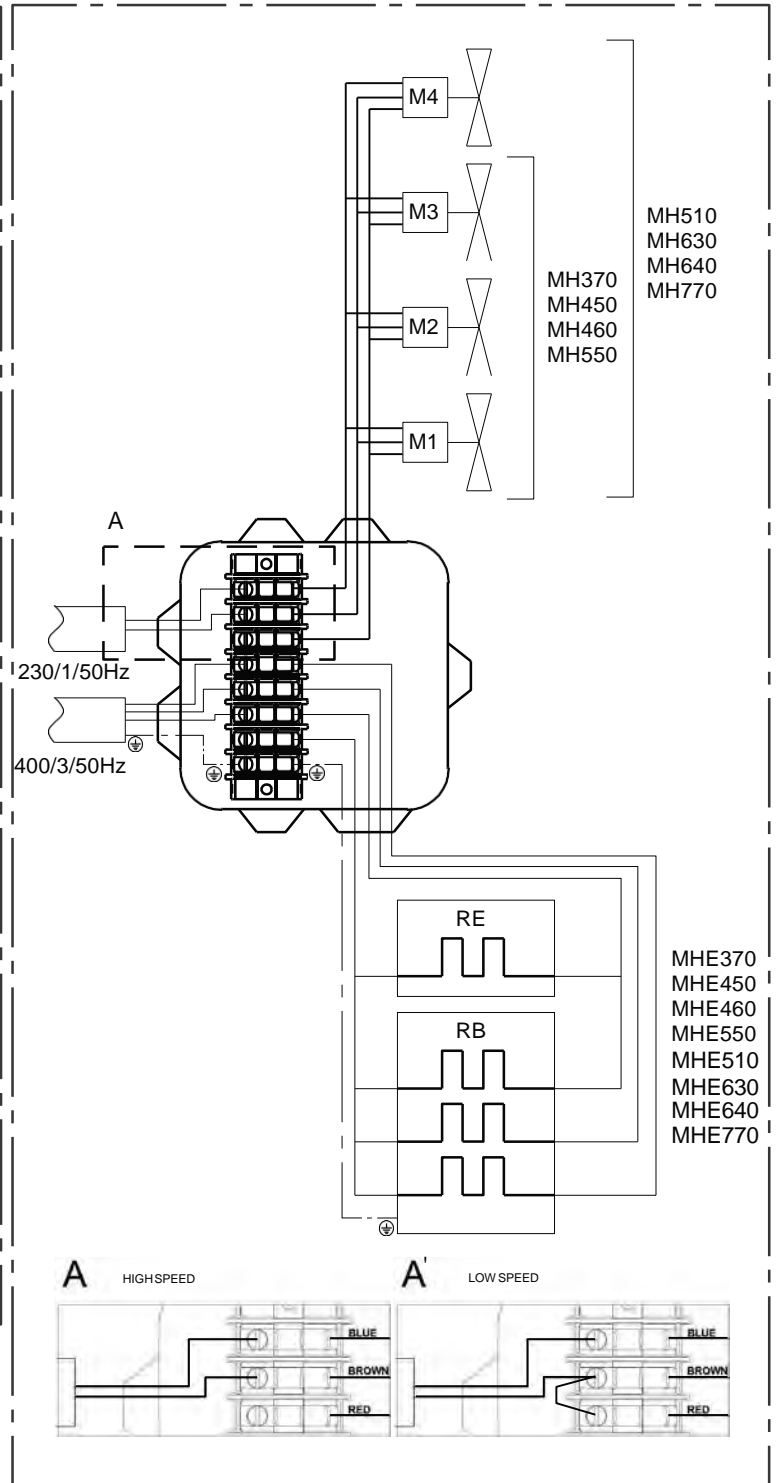
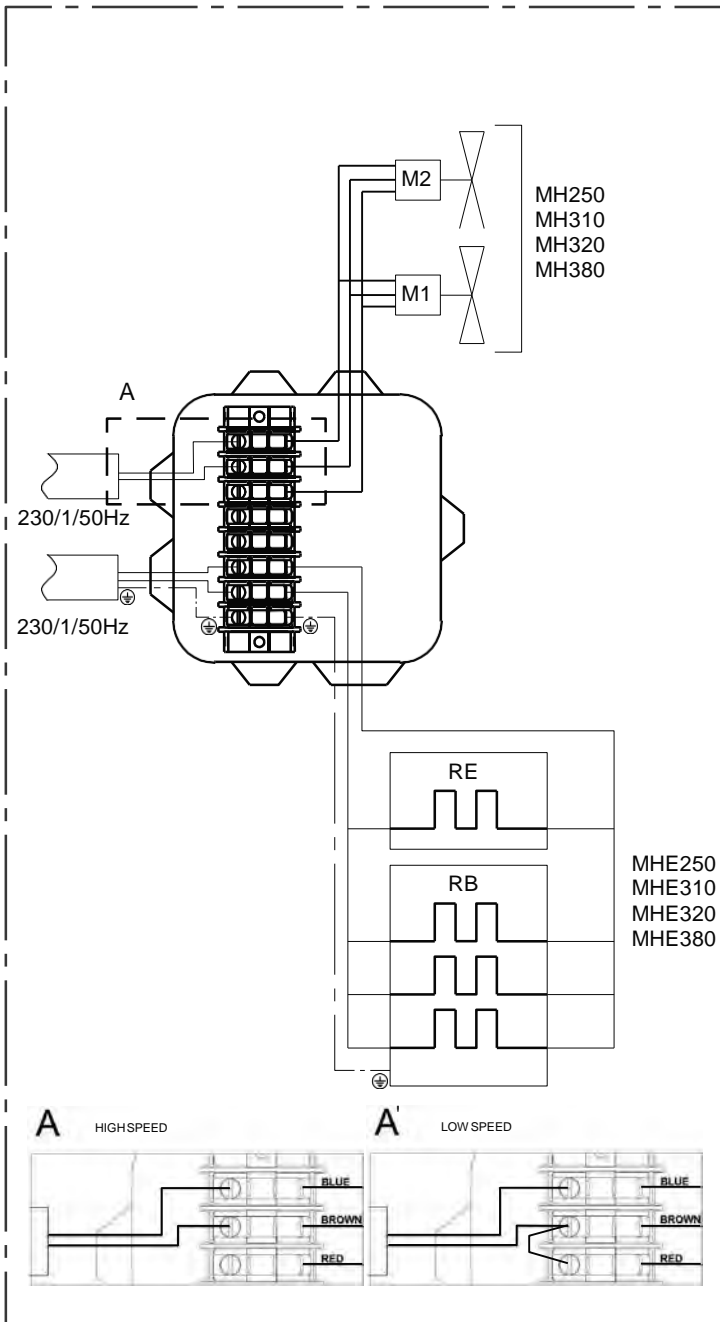

**5 . RACCORDEMENT FRIGORIFIQUE
REFRIGERANT CONNECTION
KÄLTEMITTELANSCHLUSS
CONEXIÓN FRIGORÍFICO**

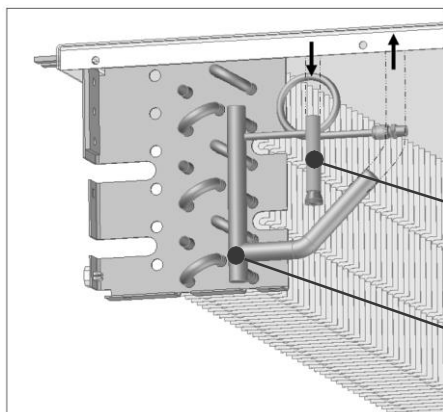

	MH320R MHE320E MH250L MHE250C	MH380R MHE380E MH310L MHE310C	MH460R MHE460E MH370L MHE370C	MH550R MHE550E MH450L MHE450C	MH640R MHE640E MH510L MHE510C	MH770R MHE770E MH630L MHE630C
ENTREE INLET EINTRITT ENTRADA	1/2"	1/2"	1/2"	1/2"	5/8"	5/8"
SORTIE OUTLET AUSTRITT SALIDA	5/8" OD	5/8" OD	3/4" OD	3/4" OD	7/8" OD	7/8" OD

**6 . POSITIONNEMENT SONDE (Pour dégivrage piloté par thermostat)
POSITIONING OF THE HEAT SENSOR (For defrost control by thermostat)
EINBAU DES TEMPERATURFÜHLERS (Abtauststeuerung über Thermostat)
POSICIONAMIENTO DE LA SONDEA (Para desescarche pilotado por termostato)**

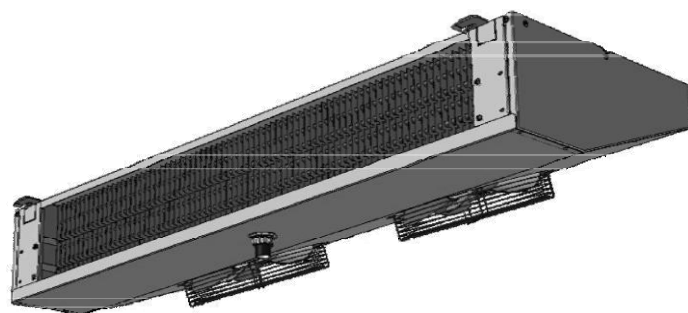
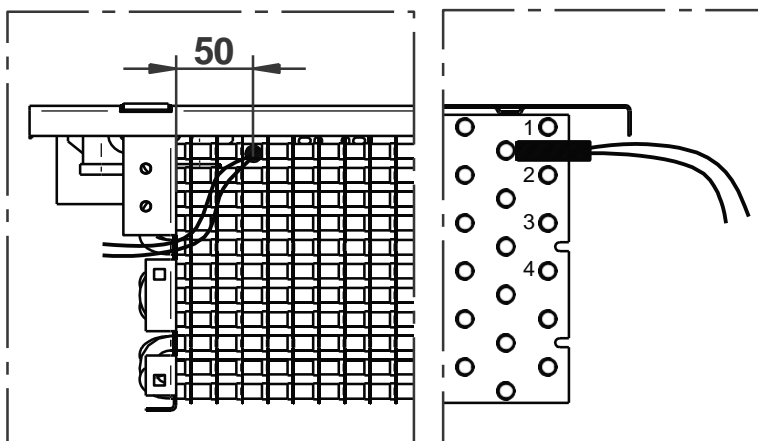

**7 . CHANGEMENT DE RESISTANCE - REPLACEMENT OF DEFROSTHEATER
 AUSWECHSELN DER HEIZSTÄBE - CAMBIO DE RESISTENCIA**

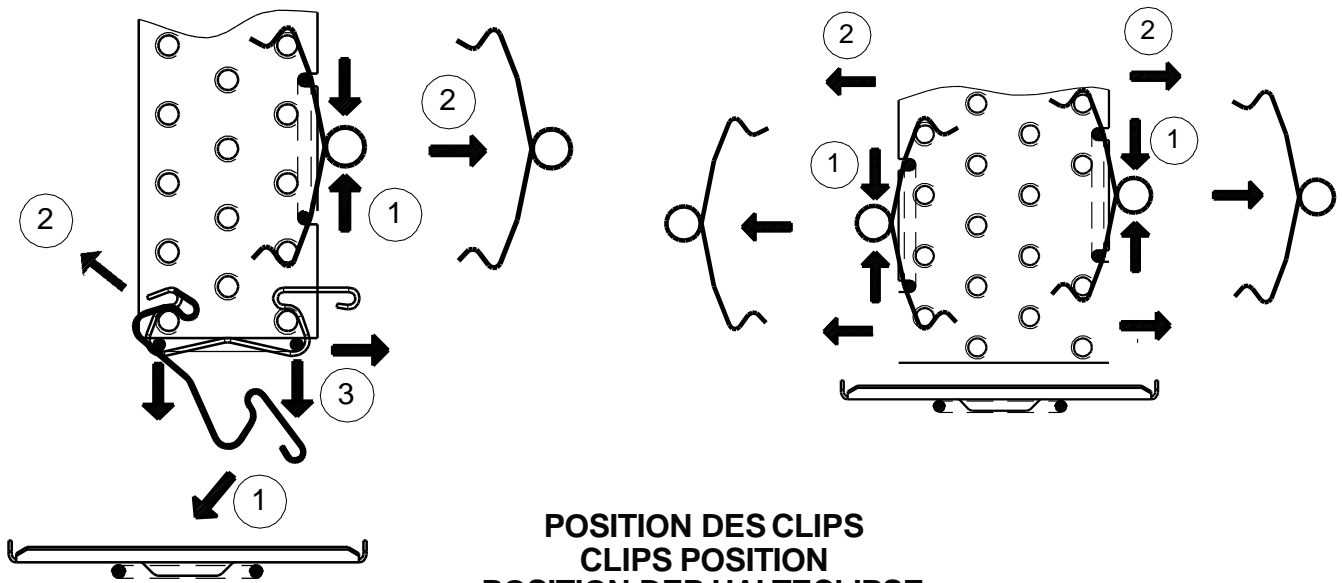
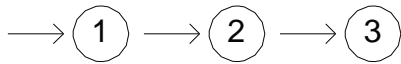

**POSITION DES CLIPS
 CLIPS POSITION
 POSITION DER HALTECLIPSE
 POSICIÓN DE LOS CLIPS**

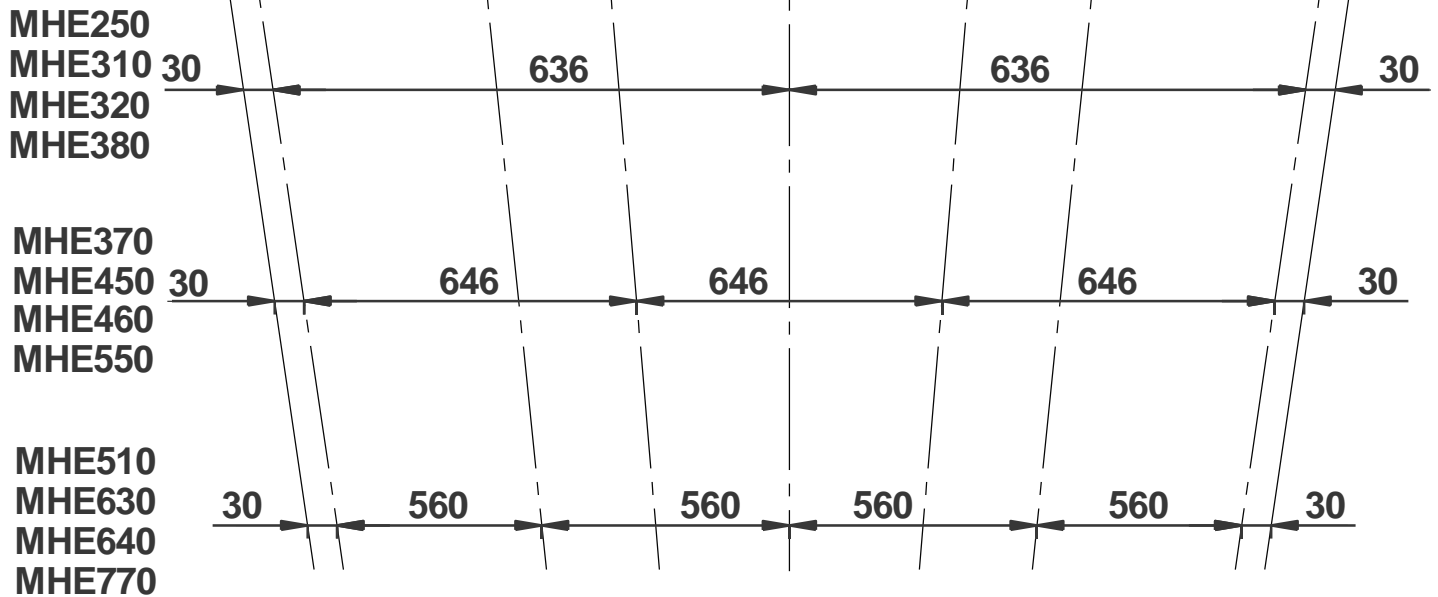
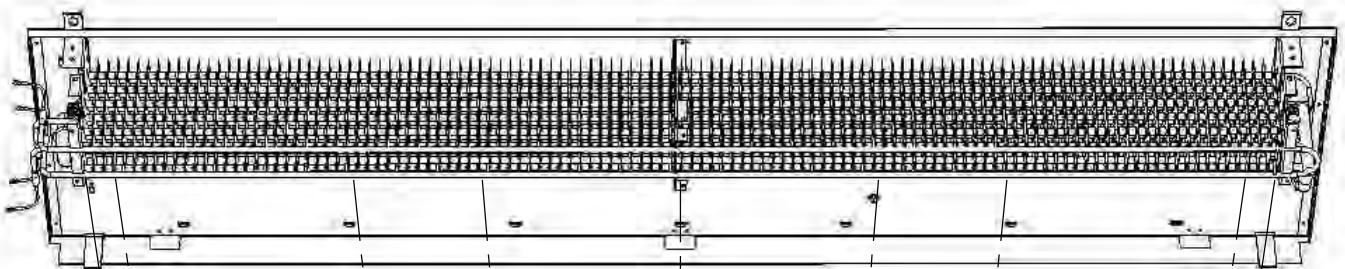

8 . ENTRETIEN MAINTENANCE WARTUNG MANTENIMIENTO

Nettoyer périodiquement à l'aide d'un produit non agressif et rincer à l'eau claire :

- la batterie : protéger les moteurs à l'aide d'un film plastique, pression maximale 3 bars et jet orienté face à la tranche des ailettes.
- les hélices, les grilles et la carrosserie.

Vérifier à la mise en route et périodiquement, le serrage des vis d'assemblage, l'état et le serrage des composants électriques.

DEFAULT DE FONCTIONNEMENT

Le moteur ne tourne pas : avant toute intervention, vérifier l'alimentation électrique. S'assurer que l'hélice tourne librement.

L'appareil vibre : vérifier les hélices et remplacer l'hélice défectueuse, s'assurer de l'absence de glace sur les hélices.

Clean periodically with a non aggressive solution and rinse with clean water:

- coil: protect the motors with a plastic film, maximum 3 bars water pressure and jet facing the fin edges.
- fan blades, fan guards and casing.

At start up and periodically, check for eventual loosen screws, the condition and tightening of the electrical connections.

FAILURES

Motor does not turn: before any intervention, check the electric supply. Make sure that the fan blade is turning freely.

The unit vibrates: check the fan blades and replace the defective one, make sure that fan blades are free of ice.

Folgende Teile regelmäßig mit einem milden Reinigungsmittel reinigen und mit klarem Wasser spülen:

- Batterie: Motoren mit einer Plastikfolie schützen, maximaler Druck des Wasserstrahls, der senkrecht zur Kante der Lamellen gerichtet sein muß: 3 Bar.
- Ventilatorflügel, Schutzgitter und Gehäuse.

Bei der Inbetriebnahme regelmäßig prüfen, ob alle Schrauben gut festgezogen sind. Zustand und Befestigung der elektrischen Komponenten überprüfen.

STÖRUNGEN

Der Motor läuft nicht: vor jeglichem Eingriff Stromversorgung überprüfen. Prüfen, ob sich die Ventilatorflügel leichtgängig drehen.

Das Gerät vibriert: Ventilatorflügel überprüfen und defekten Flügel auswechseln. Sicherstellen, daß die Flügel nicht vereist sind.

Limpie periódicamente con un producto no agresivo y aclarar con agua limpia:

- la batería: presión máxima 3 bares y chorro orientado paralelamente a las aletas.
- las hélices, las rejillas y la carrocería.

Verifique la puesta en marcha y periódicamente, el priete de los tornillos de ensambladura, el estado y la sujeción de los componentes eléctricos.

FALLO DE FUNCIONAMIENTO

El motor no gira: antes de cualquier intervención, verifique la alimentación eléctrica. Cerciórese de que el ventilador gira libremente.

El aparato vibra: comprobar las hélices y sustituir la hélice defectuosa, cerciorarse de que no haya hielo en las hélices.

LENNOX EMEA se réserve le droit d'apporter toute modification sans préavis.

LENNOX EMEA reserves itself the right to make changes at any time without preliminary notice. LENNOX EMEA

Angaben und Abbildungen unverbindlich. Änderungen vorbehalten.

LENNOX EMEA se reserva el derecho de aportar cualquier modificación sin preaviso.

