

# ***GUARDIAN Series Low Profile Evaporator HANDBOOK***

***For Units up to 20 kW***



**THANK YOU** for purchasing refrigeration products from KIRBY. Please read and apply the following procedures carefully in order to fully utilize the equipment you purchased. This instruction booklet is only applicable to the Kirby GUARDIAN range of Low Profile Evaporators.

### IMPORTANT INFORMATION

**REFER TO THE SECTIONS ON “WARNINGS AND SAFEGUARDS”, AND “INSTALLATION INSTRUCTIONS” BEFORE ATTEMPTING TO COMMISSION THIS EVAPORATOR.**

### **CONTENTS**



Warnings and Safeguards.....	2
Purpose.....	2
Standard Design Conditions .....	2



Installation Instructions. ....	3
a) Lifting of unit .....	3
b) Unpacking of Unit .....	3
c) Mounting the Unit.....	3
d) Recommended Placement and Clearance.....	4
e) Drain Spout and Drain Line.....	5
f) Refrigerant Distributor and Nozzle.....	5
g) TX Valve, Sensor Bulb and External Equaliser .....	6
h) Refrigeration Piping .....	6
i) Electrical Connection .....	6
General Commissioning Guide .....	7
Advisory Defrost Guidelines .....	7
a) Defrost Termination Requirements.....	8
b) Control Setting Guidelines .....	9
Routine Maintenance of Unit.....	9
General Decommissioning Guide .....	10
Material Safety Data Sheets – M.S.D.S. ....	10
Important Note .....	10



DIMENSIONAL DRAWING.....	11
--------------------------	----



<i>General Arrangement Drawings</i> .....	15
---	----

# GUARDIAN Series Low Profile Evaporator Handbook



## Warnings and Safeguards

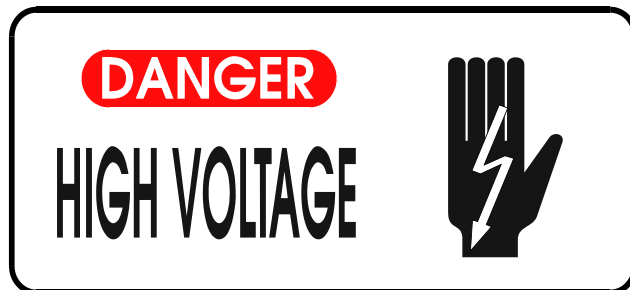

**Under no circumstances should anyone other than a qualified person attempt to gain access to the interior of the unit without first ensuring electric power is disconnected.**

- Personal Protective Equipment such as gloves, eyewear and footwear should be used during any work carried out on this product.
- Installation, commissioning, testing, decommissioning and service maintenance should be performed only by qualified personnel (refrigeration mechanics and/or electricians) who have sufficient knowledge in this type of equipment. It is the purchaser's responsibility to co-ordinate with qualified personnel as required.
- All units are pressurised with dry air or Nitrogen gas. Care must be taken to discharge the pressurised gas carefully prior to installing or commissioning the equipment.
- Avoid contact with sheet-metal edges and the coil fins. They can be sharp and are a potential personal injury hazard.

• Refrigerant can be harmful if it is inhaled and/or makes contact with exposed skin. Refrigerant must be used and recovered responsibly. Extreme care must be taken when handling refrigerant, as personnel injury or death may occur.

- All field wiring must conform to the requirements of the equipment and all applicable National and Local Codes. All power sources must be disconnected before the commencement of any service, maintenance or electrical work.
- Avoid contact refrigerant pipes and heat transfer surfaces when the equipment is operating. Their extreme hot or cold surfaces may result in skin burns.

• **WARNING:** Do not insert any object into operating fans. Ignoring this warning may result in personal injury and/or severe equipment damage and consequences.

- Fans operate continuously even when the refrigeration system has 'cycled off'. The exception is on freezer models where the fans will cycle off during defrost.
- Keep the floor of refrigerated room dry. Slippage due to ice formation on the floor is a potential personal injury hazard.

## Purpose

These low profile evaporator ranges are standard OEM products of Kirby; they comprise both 'medium' and 'low' temperature ranges. They are intended for typical cool room and freezer room applications for the storage of vegetables, fresh meat, general foodstuffs, beverages, etc. They are not intended for environments that may have harmful, corrosive or flammable atmospheres or for the storage of corrosive or flammable chemicals. 'Marine' environments are considered corrosive; please consult Kirby before installing in this environment.

## Standard Design Conditions

**MAXIMUM ALLOWABLE PRESSURE (PS/PSS)**

AS/NZS5149.2 UNIT DATA	
PS (KPag)	PSS (KPag)
3000	Not applicable.

Medium temperature range evaporators (Kirby KMH series) are designed at  $-4^{\circ}\text{C}$  saturation suction temperature (SST) and 6 KTD to suit room temperature from  $-6^{\circ}\text{C}$  to  $+22^{\circ}\text{C}$  (refer to maximum and minimum allowed KTD for specific SST), for use in 'medium duty' commercial cool room applications. For rooms below  $2^{\circ}\text{C}$ , additional defrosting means may be required. R404A, R448A, R507A, R513A and R134a are recommended refrigerants. For other refrigerants, and R134a, please refer to sales data sheet for capacity variations.

Low temperature range evaporators (Kirby KLH series) are designed at  $-24^{\circ}\text{C}$  SST and 6 KTD to suit room temperatures from  $-1^{\circ}\text{C}$  to  $-38^{\circ}\text{C}$  (refer to maximum and minimum allowed KTD for specific SST), for use in 'medium duty' commercial freezer room applications. R404A, R448A and R507A are the recommended refrigerants. For other refrigerants, please refer to sales data sheet for capacity variations. For lower temperatures design variations may be required.

These standard evaporators cannot use Ammonia ( $\text{NH}_3$ ) as refrigerant.

For special design requirements (non standard conditions and/or refrigerants such as Glycol, Hydrocarbons, etc), please inquire with your local representatives and/or KIRBY local branches, or call our national telephone number 13 23 50 for your nearest available information resources.



## Installation Instructions.

This product must be installed and maintained in accordance with the following:

- AS/NZS5149:2016 – Parts 3 & 4 (as applicable)
- AS4041:1998 – Pressure Piping
- Refrigerant Handling Code of Practice, Part 2

Useful information-

- Ozone Protection and Synthetic Greenhouse Gas Management Act 1989 (and amendments) and Regulations 1995
- AIRAH, DA19 – HVAC&R Maintenance
- CIBSE Code M - Commissioning Management

**NOTE- There may be other applicable Codes and Standards that must be considered. It is the responsibility of the Installer and Owner to ensure all requirements are considered and complied with.**

### a) Lifting of unit



As a guide for lifting the weight of the unit is noted on the packaging label next to the model and serial number. Use the appropriate mechanical handling equipment to lift the unit into place.

### b) Unpacking of Unit

When unpacking, check for any damage to packing material or the unit itself, which may affect the unit's performance. **If any such damage is evident, please contact your Kirby branch.**

### c) Mounting the Unit

These evaporators can be mounted with threaded rods or bolts. Use 5/16" bolts and washers or rods for up to 110kg (250 lb), 3/8" for up to 270kg (600 lb).

To comply with HACCP and/or relevant regulations for food safety, the area above the evaporator must be sealed or exposed in such a way to facilitate hand cleaning without the use of tools. So depending on the end user's preference, the evaporators can be installed either,

- Using threaded rod and allow sufficient space between the top of the evaporator and the ceiling for cleaning, or
- Flush mount the evaporator to the ceiling, seal the gap between the top and the ceiling with food benign sealant to prevent accumulation of any foreign matter.

All evaporators shall be mounted professionally and levelled properly so that condensate drains from the evaporator efficiently. Adequate support must be provided to hold the weight of the evaporator plus the weight of the refrigerant and any frost that may accumulate on the coil surface. The use of weight lifting equipment is highly recommended whenever possible.

#### d) Recommended Placement and Clearance

Some general rules for evaporator placement shall be followed:

- The air pattern shall cover the entire room or effective area.
- Do **NOT** locate evaporators over doors.
- Locate aisles, racks, etc so as not to hinder the discharge or return airflow of the evaporator.
- Locate relative to compressors for minimum pipe runs.
- Locate condensate drains for minimum pipe runs.

Minimum clearance shall be guaranteed:

- S1 - Allow 350mm or more between the wall and air on side of the coil, for airflow.
- S2 – Allow 400mm or more between the wall and each side of front access panel (refrigeration and electrical access panels), for service convenience.

#### Where one side of wall mounting is satisfactory.

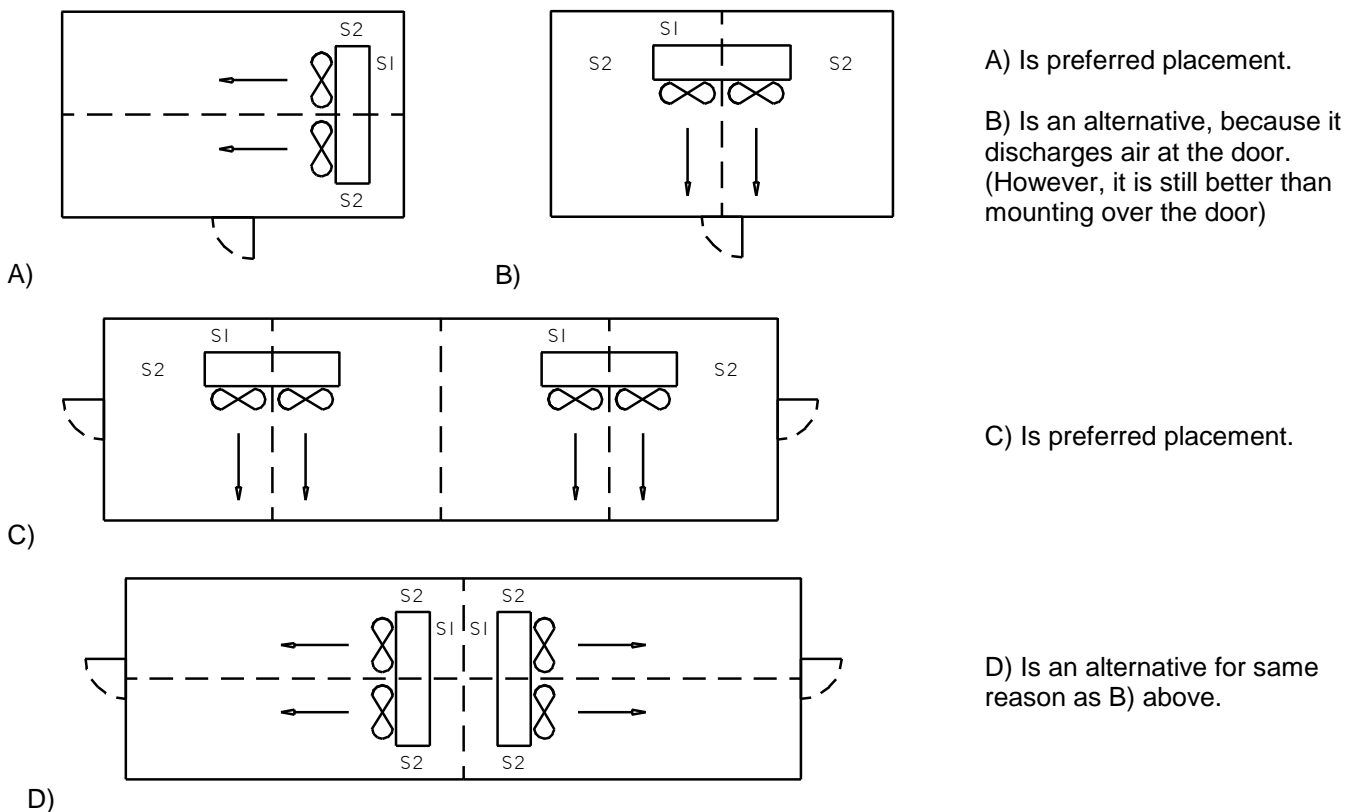

**Where one side of wall mounting will not accommodate all required units or air throw distance must be considered.**

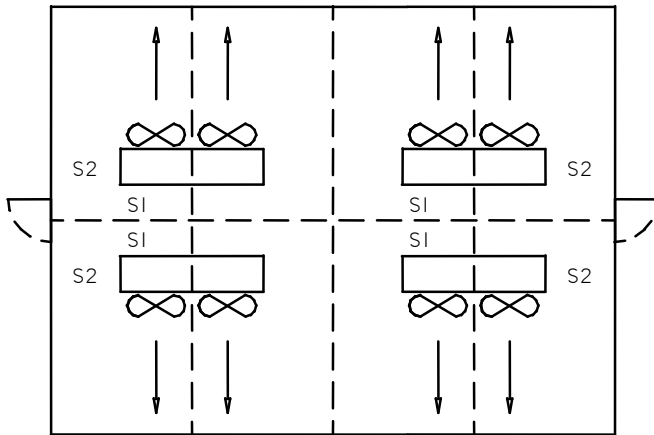

Preferred Placement

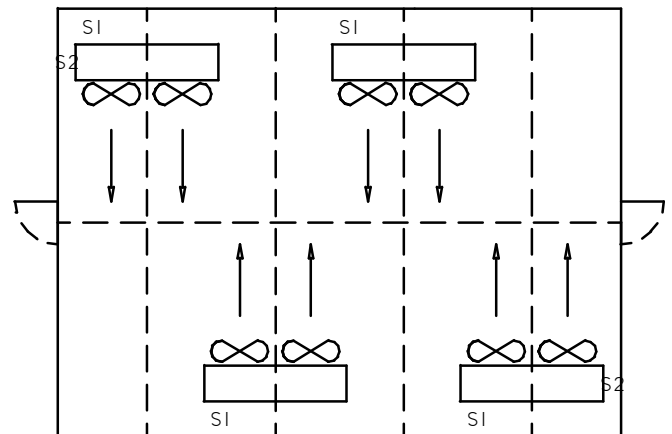

Second Choice due to possible airflow collision and defrost difficulties

### e) Drain Spout and Drain Line

Loosely shipped with the purchased unit, there is a 32mm BSP O.D. drain spout (*the spout assembly is cable tied to a fan guard. If it is not present please notify your local Kirby branch.*) It comprises of a tube, a seal and a nut (three parts). Reassemble these 3 parts in the hexagon drain hole in the tray in such a way to have the tube and the seal at the inside of the tray, and the nut at the outside of the tray (shown as below). The seal is seated in-between the tray and the tube. Position the tube to match the hexagon drain hole properly. Hand tighten the nut to ensure no condensate water leaks. Over tightening or use of tools to tighten the nut may result in damage of the nut thus causing condensate water leakage.

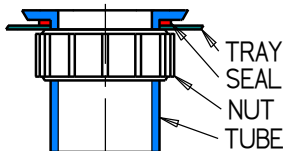

Hand tighten the nut and test with water to ensure no water leaks

Ensure that the installation complies with HACCP and/or relevant regulations for food safety, and the end user's preferences when choosing copper, stainless steel or PVC material for condensate drain lines. For low temperature applications, proper insulation and heating cable shall be provided to prevent the drainpipe from freezing. Provide a minimum 150mm per meter pitch to condensate drain lines for proper drainage. Drain lines should be at least as large as the evaporator drain connection. All condensate drain lines must be trapped to prevent outdoor air and odours entering the refrigerated room, and must never be connected directly to the sewer system. All traps must be located in a warm ambient to prevent water from freezing. It is recommended that the drain line be kept to a minimum length within the refrigerated room.

### f) Refrigerant Distributor and Nozzle

To obtain the best performance of the evaporator, the distributor body shall be mounted vertically to ensure refrigerant liquid being distributed evenly to all the circuits.

For each unit through the whole range of guardian series evaporators, there is only one nozzle supplied and fitted in the distributor corresponding to the unit's designed refrigeration capacity. Through coil circuiting design, we have selected a nozzle that has an optimised capacity between R507A/R404A for each model in the range. For application on R134a, R407F/R448A/R449A/R513A or selections outside the nominated application range refer to your local Kirby representative as nozzle selection may have to be changed.

## g) TX Valve, Sensor Bulb and External Equaliser

Refer to the sales data sheet regarding selection of TX valves or EEV for each unit. For best performance, the TX valve or EEV should be installed as close to the distributor as possible. Follow TX valve or EEV manufacturer's recommendations/guidelines to select expansion valve for different applications.

Locate the expansion valve sensor bulb on the horizontal section of suction line and close to the suction header. For a satisfactory TX valve operation, good thermal contact between the sensor bulb and the suction line is essential. Follow TX valve manufacturer's recommendations when positioning TX valve and sensor bulb. Incorrect installation may result in poor evaporator performance.

For TX valve with external equalizer, a ¼" tube brazed to the coil suction line is supplied for that purpose.

Note: With modern high quality expansion valves, refrigeration leakage through the equaliser line is at a minimum and the TX valve operation is not affected. Thus the external equaliser connection could be made either upstream or downstream of the sensor bulb.

## h) Refrigeration Piping

Refrigeration piping work shall be carried out professionally by qualified refrigeration mechanics in accordance with applicable national and local regulations and in conformance with good engineering practices required for the proper operation of the refrigeration system.

All evaporators supplied by Kirby are supplied clean and internally charged with dry air or nitrogen to prevent oxidation and ingress of moisture or foreign matter. Care shall be taken during installation of the piping to prevent entrance of foreign matter or moisture by minimising the time that the piping is uncapped.

The interconnecting refrigeration pipe size is not necessarily the same size as the outlet on the unit. The pipe sizes shall be selected/calculated based on the best compromise of minimizing refrigerant pressure drop and refrigerant velocity to ensure efficient oil return. Kirby can assist in the calculation of pipe sizes.

Always consider the proper location for the TX valve sensor bulb when connecting the suction line to the suction fitting of the unit. Horizontal suction lines shall slope away from the evaporators to allow the oil return freely to the compressor by gravity. A 1:100 slope is considered sufficient. It is a good engineering practice to fit an oil trap when the suction line rises above the evaporator.

If in doubt during the installation, please consult with your local sales representatives and/or application engineers from Kirby for technical support.

## i) Electrical Connection



**All electrical connections must be carried out by a licensed electrical contractor and in accordance with the relevant regulations. Electrical wiring shall NOT be modified without prior permission from Kirby. Failure to follow this procedure may cause death and void warranty.**

The Kirby KMH & KLH series of evaporators are supplied pre-wired to "WAGO" terminal blocks located in the electrical compartment of the evaporator. The wiring diagram for each pre-wired evaporator is located on the inside of the Electrical Access Front Panel. Refer to the sales data sheets for all the information regarding voltage and current for fan motors and element heaters.

After electrical installation units should be tested for correct current draw and rotation of fan motors.

## General Commissioning Guide

Refrigeration system commissioning shall be carried out professionally by qualified refrigeration mechanics in conformance with good engineering practices required for the proper operation of the refrigeration system.

After all installation and electrical work is completed, the entire refrigeration system must be leak tested. After satisfactory testing the refrigeration system, then necessary refrigeration lines shall be insulated. The insulation located in outdoor environments shall be protected from UV exposure.

Before charging the refrigerant, the entire refrigeration system shall be evacuated by connecting a good, high vacuum pump to both the high-pressure side and low-pressure side service valves or ports.

Installing a liquid line drier and a sight glass in a refrigeration system is sound engineering practice. The liquid line drier will ensure all refrigerant supplied to the refrigeration system is clean and dry. The sight glass is a useful device to ensure sufficient refrigerant is supplied to the refrigeration system.

Refrigerant charging shall be in liquid form at the high-pressure side of the system such as condenser or liquid receiver. If the refrigerant charging must be carried out through the suction side of the compressor, charge in vapour form only.

Double check all field wiring connections and factory terminals. Factory connections can vibrate loose during shipment. Ensure correct fan motor rotation, airflow is induced from coil side and forced out of fan motor side.

Check the room thermostat for normal operation and adjust if necessary.

## Advisory Defrost Guidelines (6FPI Coil)

In order to maximise efficiency and airflow, the following advisory defrost data has been compiled. Defrost data is minimum number of defrosts required per 24 hrs for average room loads.

SST	-30	-24	-18	-12
DEFROSTS AT MAX. KTD	7	7	6	6
DEFROSTS AT 6KTD	5	4	4	4
DEFROSTS AT MIN. KTD	4	3	3	4

Advisory defrost timing for -18°C room

KTD	LIGHT LOAD		HEAVY LOAD			LIGHT LOAD		
	1	2	3	4	5	6	7	8
10	X	X	X	X	X	X		X
8		X	X	X	X	X		X
6		X		X		X		X
4			X			X		X

Each column represents a 3 hour period during the day. An X indicates the hour that a defrost should commence. "Heavy Load" represents the nominal 'working period' of each day.

Max KTD reflects the limits of distributor selection, and is not recommended for continuous operation in freezer conditions.

## Advisory Defrost Guidelines (4.5FPI Coil)

In order to maximise efficiency and airflow, the following advisory defrost data is tabulated for your reference. Defrost data is minimum number of defrosts required per 24 hrs for average room loads.

SST	CHART 1					CHART 2			
	-36	-30	-24	-18	-12	-10	-8	-6	-4
DEFROSTS AT MAX. KTD	8	7	7	6	6	10	9	8	7
DEFROSTS AT 6KTD	5	5	4	4	4	8	7	6	5
DEFROSTS AT MIN. KTD	5	4	3	3	4	6	6	5	4

Advisory defrost timing for -18°C room (Chart 1)

KTD	LIGHT LOAD		HEAVY LOAD			LIGHT LOAD		
	1	2	3	4	5	6	7	8
10	X	X	X	X	X	X		X
8		X	X	X	X	X		X
6		X		X		X		X
4			X		X			X

Advisory defrost timing for 0°C room (Chart 2)

KTD	LIGHT LOAD		HEAVY LOAD			LIGHT LOAD		
	1	2	3	4	5	6	7	8
10	X	X	X	X	X	X	X	X
8	X	X	X	X	X	X	X	
6	X	X	X	X	X		X	
4	X		X	X		X	X	

Each column represents a 3 hour period during the day. An X indicates the hour that a defrost should commence. "Heavy Load" represents the nominal 'working period' of each day.

Max KTD reflects the limits of distributor selection, and is not recommended for continuous operation in freezer conditions.

#### HIGH GLIDE REFRIGERANTS:

For high glide refrigerants (R407F, R448A, R449A) the RH charts and these tables are based on using the MID POINT temperature to determine the KTD. Eg- 6KTD at -4C sst on R404A becomes 4KTD on R448A due to the glide. Kirby recommends using 4KTD as the basis of selection as it gives similar humidity outcomes due to higher watts per K due to the change in refrigerant temperature in the coil. If a selection is made with dewpoint to determine the KTD, at 6KTD it is necessary to use 8KTD in this table and in RH charts.

### a) Defrost Termination Requirements

Defrost time for average loads should be approx. 20 - 25 minutes including drainage. Time will vary with different degrees of ice build up.

**Time Termination** – should be set to ensure complete defrost at the heaviest load condition. Typically allow 25-30 minutes with safety reset at 35 minutes.

**Temperature Termination** – setting depends on frequency and severity of defrosts and location of sensing device. If using the standard defrost termination thermostat (MCC126-1), the defrosting guidelines above should be used.

**Pressure Termination** – can be incorporated into the defrost in a number of ways. Whatever method is preferred, it must be noted that the temperature of the fins will be somewhat lower than the saturation temperature corresponding to the refrigerant pressure. Therefore a somewhat higher refrigerant temperature must often be allowed for when setting the pressure control. See table below. It is also not recommended to control the fan delay by pressure as very low pressure will be reached quite quickly after defrost on TX valve systems when the fans are not running. It is preferable to combine the pressure termination with a time clock for fan delay.





**Heater Safety Thermostat** – units equipped with electric defrost heaters are fitted with a Heater Safety Thermostat as standard. This control cuts the supply to the heaters in the advent of a controller or sensor failure to prevent excessive temperatures/pressures developing. The operating point is +20°C. It is recommended that this control not be over-ridden, rewired or removed. This control will not restart the refrigeration system

**Fan Delay Requirements** – may vary with application, conditions and control method but should not be more than 5 minutes. Fan delays with MCC143-1 will be of the order of 2-4 minutes.

## b) Control Setting Guidelines

Each application should be treated on its merits; however the following is given as a guide. During the commissioning, this data should be used as a reference initially. It is installer responsibility to fine-tune the control settings to achieve the satisfactory defrost results.

Termination Type	Sensor Location	Setting	Fan Delay
Time	n/a	25 – 30 mins	4 mins (max)
Temperature	End Plate in Elec. Sect.	11° - 14°C	1° to -2°C
Pressure (Gauge)	Header	770-790kPa R404A & 800-820kPa R507A	n/a
		800-820kPa R448A & 790-810kPa R449A	n/a
		690-710kPa R407C & 810-830kPa R407F	n/a
		340-360kPa R134a & 390-410kPa R513A	n/a

The above guidelines allow for relatively heavy defrost loads. Shorter times or lower settings must be verified on the installation. Pressure termination given for R407F, R448A, R449A and R404A corresponds to the mid point at the required temperature.

If electronic controller is used for defrost operation of the unit, it is the responsibility of the installer to establish control settings by following the guidelines and recommendations of controller manufacturer.

Refer to the applicable Kirby Pressure/Temperature Chart.

All data given is for defrost without refrigerant pump down.

**Pump-down** is not recommended for electric defrost using pressure and/or temperature control. There is clear evidence in testing that positive defrosting of the distributor, leads, header and suction line cannot be achieved without refrigerant being present in the coil. Additional means, such as heater tape around these components, may be needed if using pump-down. Longer defrosting time and / or more frequent defrosting may also be necessary to ensure long-term ice built up does not occur.

**Pump-down** may be used with time termination. The defrost time will be longer and requirements must be determined on individual systems.

Defrost data above based on R507A/R404A refrigerant. For other refrigerant application, it may be necessary to vary the number of defrosts per day to maintain efficient performance.



## Routine Maintenance of Unit

All Kirby low profile evaporators are designed to have low service maintenance requirements. Based on normal operation conditions and working environment, a service maintenance schedule shall be established after the successful completion of commissioning, to ensure the evaporators operate efficiently and running costs are kept at a minimum. The following items shall be checked and recorded during service maintenance,

- Visually inspect the evaporators looking for corrosion, unusual vibrations, oil stains and drain tray blockage. The drain tray should be cleaned regularly with warm soapy water.
- Clean the evaporator fins by using a soft brush, low pressurised water and/or commercially available evaporator coil cleaner. Never use an acid based cleaner. Follow label directions for appropriate use. Flush and rinse coil until no residue remains.
- Check that each fan rotates freely and quietly, fan guards are free of airflow obstructions and fan screws are tight.
- Inspect electrical wiring, connections and components looking for damaged wiring, loose connections and worn components.
- Check that all heaters are in their original positions contacting either fins or drain tray.

- Ensure even coil frost formation pattern during operation. An uneven frost pattern may indicate a distributor blockage or incorrect refrigerant charge.
- Look for abnormal accumulation of ice patterns and adjust the defrost cycles accordingly.
- Check the superheat and adjust TX valve accordingly.

All power must be disconnected before cleaning and/or service maintenance. The condensate drain tray also serves as a cover of hazardous (hot, cold, electrical and moving) parts. Operation of evaporators without condensate drain tray constitutes a safety hazard.

The service maintenance record as well as this "Installation and Operation Instructions" shall be kept together in a safe place as a future reference.

## General Decommissioning Guide

In order to remove the evaporator from its mounting place, the following procedures need to be carried out professionally by qualified personnel. Failure to do so may result in personal injury or death, property damage by fire or explosion. Discharge of refrigerant to atmosphere is illegal and may result in heavy fines by relevant regulatory authorities

- Pump down the entire refrigerant charge into the liquid receiver or appropriate container such as reclaim cylinder, and shut related valves. All reclaimed refrigerant that is not re-used must be taken to an approved refrigerant recycling or destruction facility. Kirby Branches will accept the used refrigerant.
- Disconnect the power supply. Remove all necessary field electrical wiring and related components, leaving the earth wire to the last.
- Disconnect the drainpipe.
- Care must be taken when de-pressing the Schrader valve core in order to balance the pressure between the evaporator and ambient. There may be a small amount of refrigerant trapped in the oil, the pressure rise in the evaporator will boil and vaporise the refrigerant resulting in a potential personal injury hazard.
- Cut and solder seal the refrigeration liquid line and suction line pipe connections.
- Remove the evaporator from its mounting place. Adequate support must be provided to hold the weight of the evaporator. The use of weight lifting equipment is highly recommended whenever possible.

## Material Safety Data Sheets – M.S.D.S.

These are available from your nearest Kirby Branch for all refrigerants that this range of evaporators are approved for.

## Important Note

- To ensure Kirby Guardian series evaporators operate efficiently and for a long working life, always obtain genuine replacement parts from your local Kirby Wholesale Branch. Genuine replacement parts are covered by the warranty. Refer to the Standard Terms & Conditions of Sale in the Price Guide for warranty statements.
- Continuous product improvement is our company policy. Kirby reserves the right to make changes in product specifications and/or this instruction manual without notice.
- Kirby is dedicated to providing safe products and protecting the environment by complying with all applicable national laws and regulations governing environmental protection. New and used refrigerants cannot be vented into atmosphere. Reclaim all used refrigerants. Environmental regulations are constantly updated. Ensure your refrigerant handling procedure follows correct regulations.

### DIMENSIONAL DRAWING

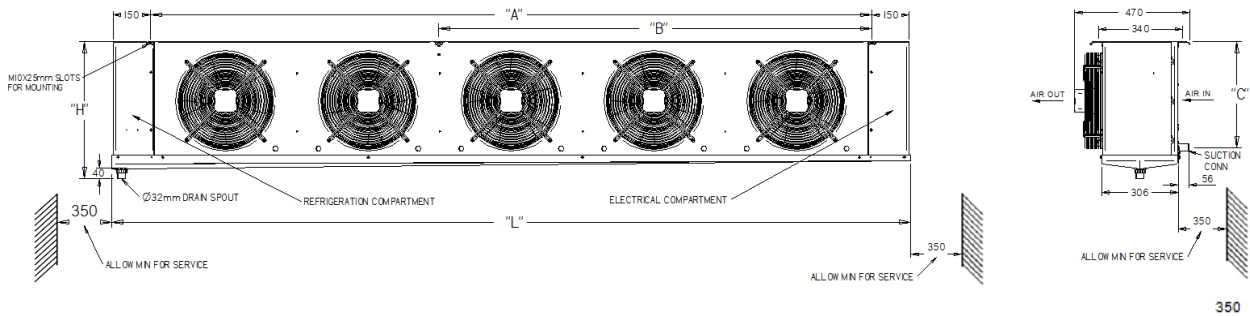

350

MODEL	KMSHA19P1-1	KMSHA19Z1-1	KMSHA29E1-1	KMSHA29S1-1	KMSHA39P1-1	KMSHA49P1-1	KMSHA49Z1-1
A	440	440	845	845	1250	1660	1660
L (LENGTH)	750	750	1155	1155	1560	1970	1970
H (HEIGHT)	494	494	494	494	494	494	494

MODEL	KMSHB19P1-1	KMSHB29E1-1	KMSHB29S1-1	KMSHB29Z1-1	KMSHB39S1-1	KMSHB39Z1-1	KMSHB49S1-1	KMSHB59Z1-1
A	540	1175	1175	1175	1745	1745	2320	2890
B							1165	1735
L (LENGTH)	850	1485	1485	1485	2060	2060	2360	3200
H (HEIGHT)	545	545	545	545	545	545	545	545

MODEL	KLSHA19Z1-1	KLSHA29P1-1	KLSHA29Z1-1	KLSHA39P1-2	KLSHA39S1-2	KLSHA49Z1-2
A	440	845	845	1250	1250	1660
L (LENGTH)	750	1155	1155	1560	1560	1970
H (HEIGHT)	494	494	494	494	494	494

MODEL	KLSHB19S1-1	KLSHB29P1-2	KLSHB29Z1-2	KLSHB39S1-2	KLSHB39Z1-2	KLSHB49Z1-2	KLSHB59Z1-2
A	540	1175	1175	1745	1745	2320	2890
B						1165	1735
L (LENGTH)	850	1485	1485	2060	2060	2630	3200
H (HEIGHT)	545	545	545	545	545	545	545

MODEL	KMUHA29V1-1	KMUHA39X1-1	KMUHA49X1-1
A	845	1250	1660
L (LENGTH)	1155	1560	1970
H (HEIGHT)	494	494	494

MODEL	KMUHB19V1-1	KMUHB29X1-1	KMUHB39V1-1	KMUHB39X1-1	KMUHB49X1-1	KMUHB59X1-1
A	540	1175	1745	1745	2320	2890
B					1165	1735
L (LENGTH)	850	1485	2060	2060	2360	3200
H (HEIGHT)	545	545	545	545	545	545

MODEL	KLUHA29V1-1	KLUHA39X1-2	KLUHA49X1-2
A	845	1250	1660
L (LENGTH)	1155	1560	1970
H (HEIGHT)	494	494	494

MODEL	KLUHB19V1-1	KLUHB29X1-2	KLUHB39V1-2	KLUHB39X1-2	KLUHB49X1-2	KLUHB59X1-2
A	540	1175	1745	1745	2320	2890
B					1165	1735
L (LENGTH)	850	1485	2060	2060	2360	3200
H (HEIGHT)	545	545	545	545	545	545

**WIRING SCHEMATICS:**

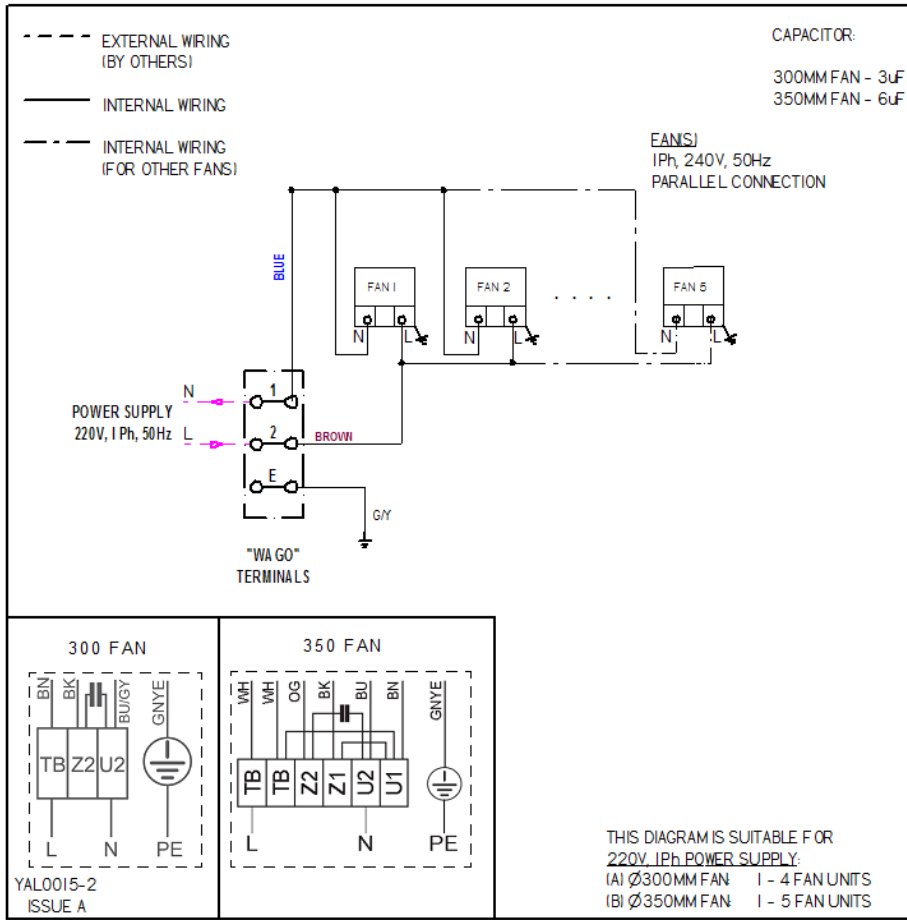

MT EVAP WITH  
 AC FANS  
 300MM FANS: 1-4  
 350MM FAN: 1-5

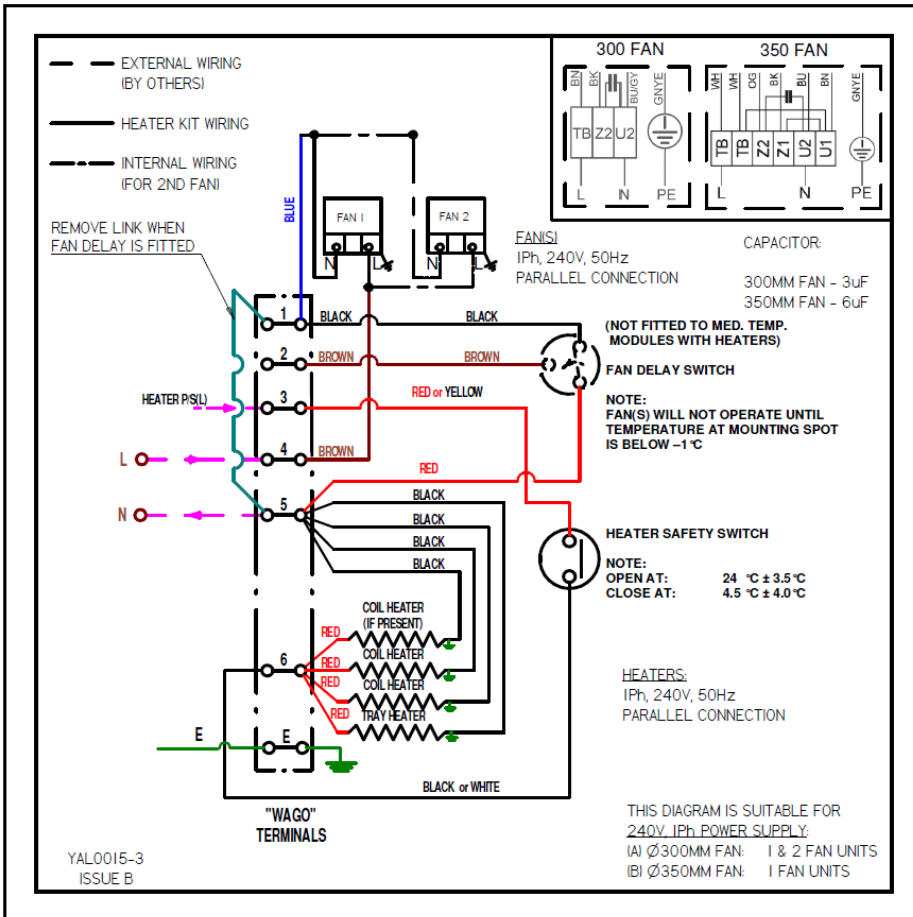

LT EVAP WITH  
 AC FANS  
 300MM FANS: 1 & 2  
 350MM FAN: 1 ONLY

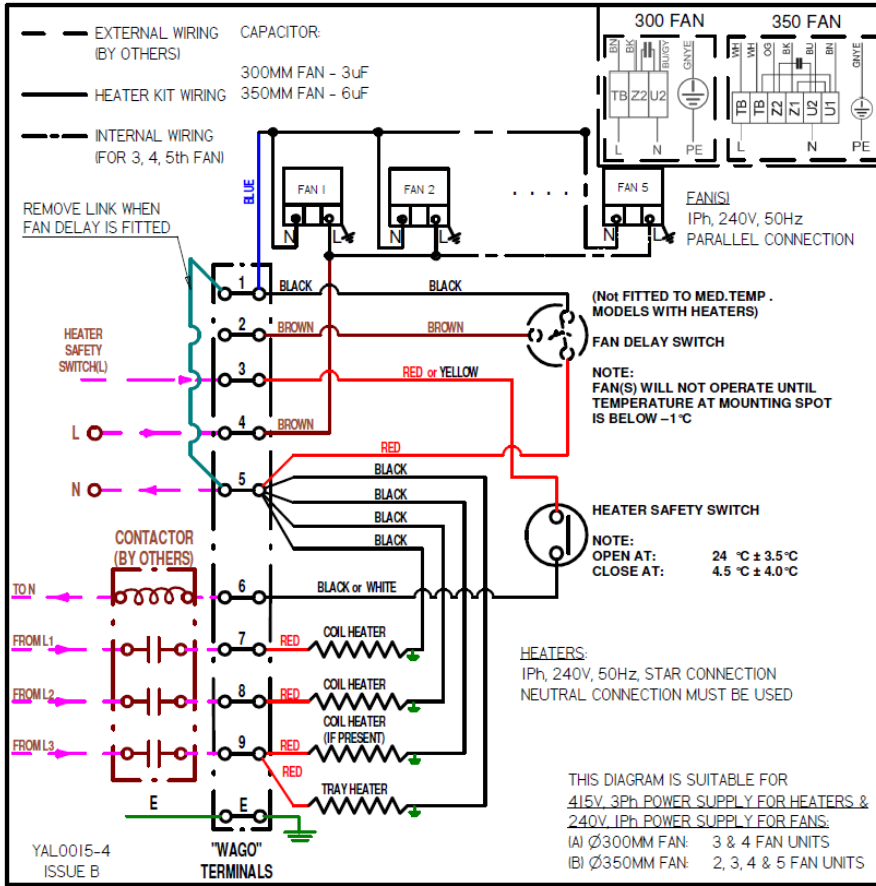

LT EVAP WITH  
 AC FANS  
 300MM FANS: 3 & 4  
 350MM FANS: 2, 3, 4 & 5

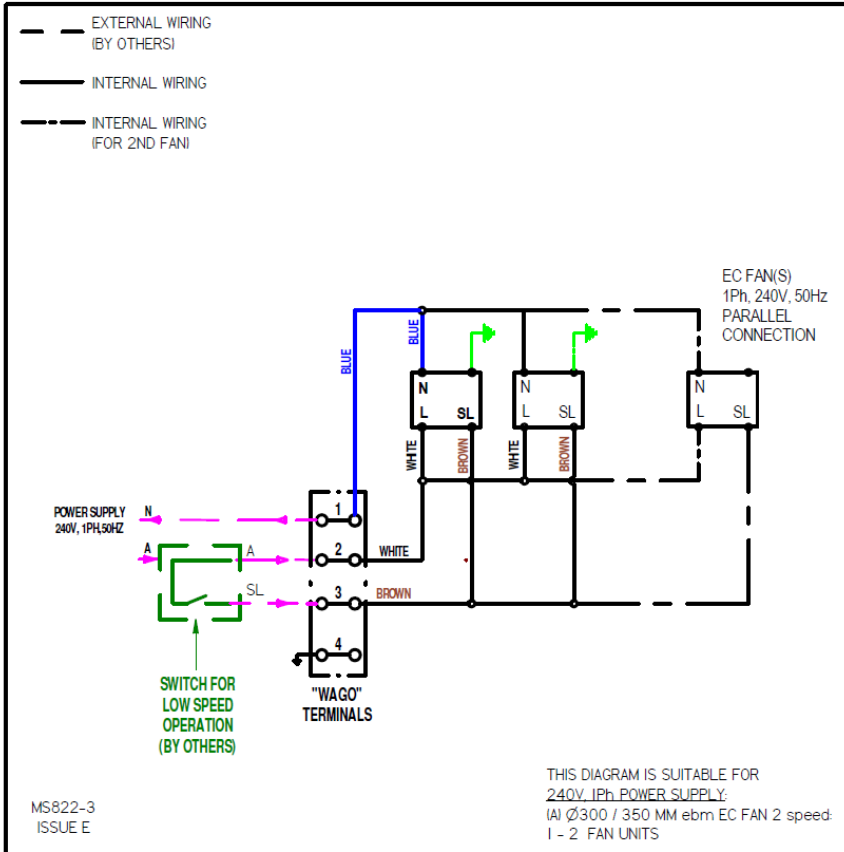

MT EVAP WITH  
 EC FAN - 2 SPEED  
 300MM FANS: 1-5  
 350MM FANS: 1-5

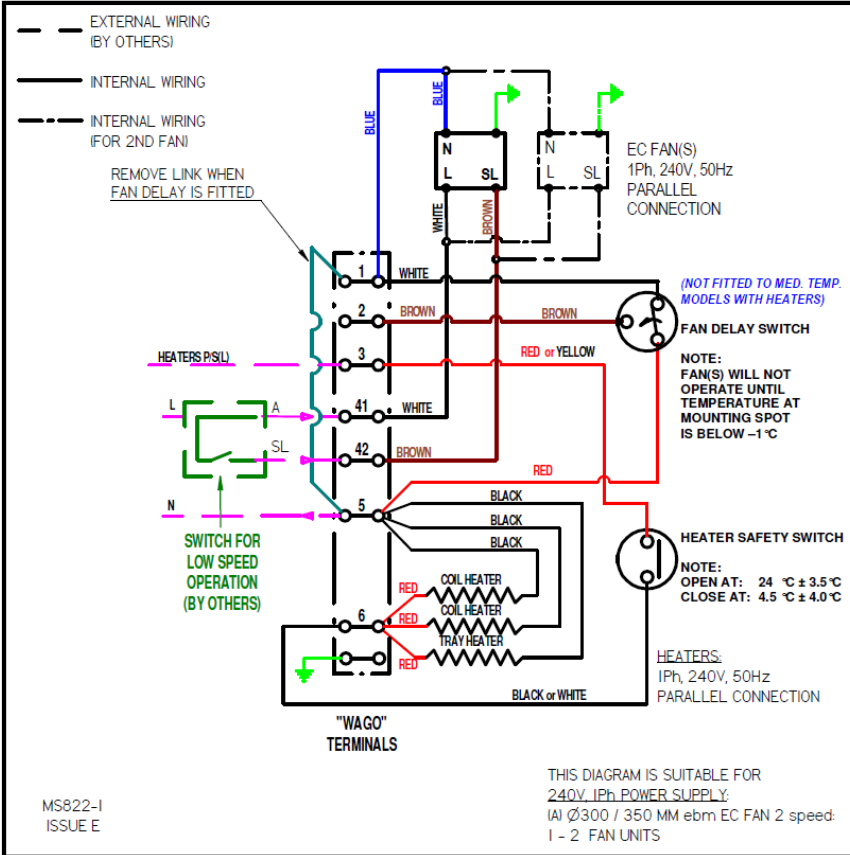

LT EVAP WITH  
EC FAN – 2 SPEED  
300/350MM FANS: 1,2

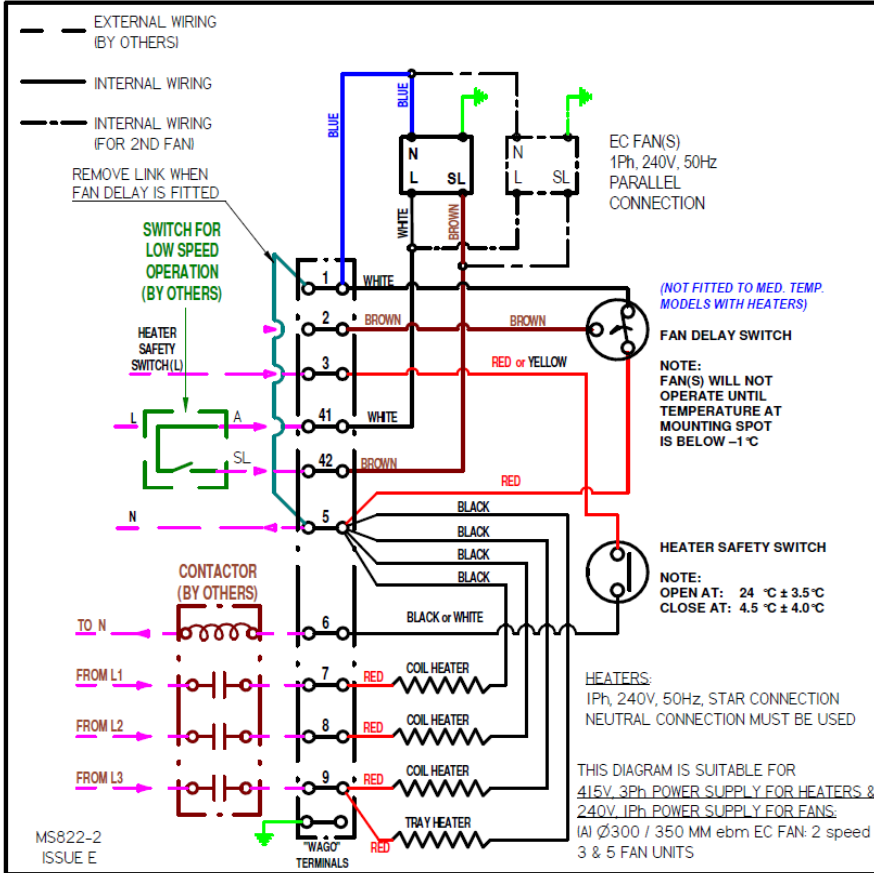

LT EVAP WITH EBM EC  
FAN – 2 SPEED  
300/350MM FANS: 3,4,5



## General Arrangement Drawings

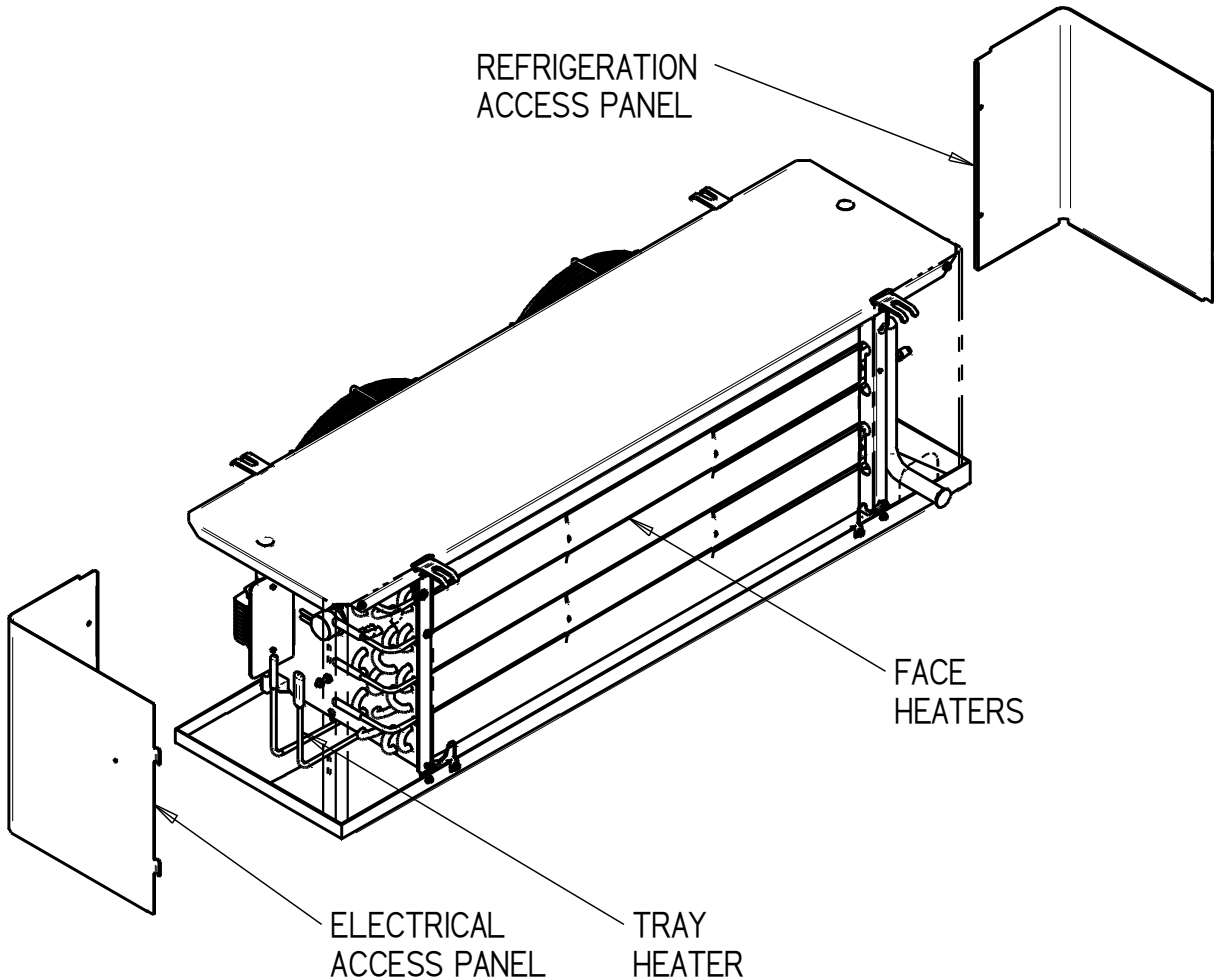
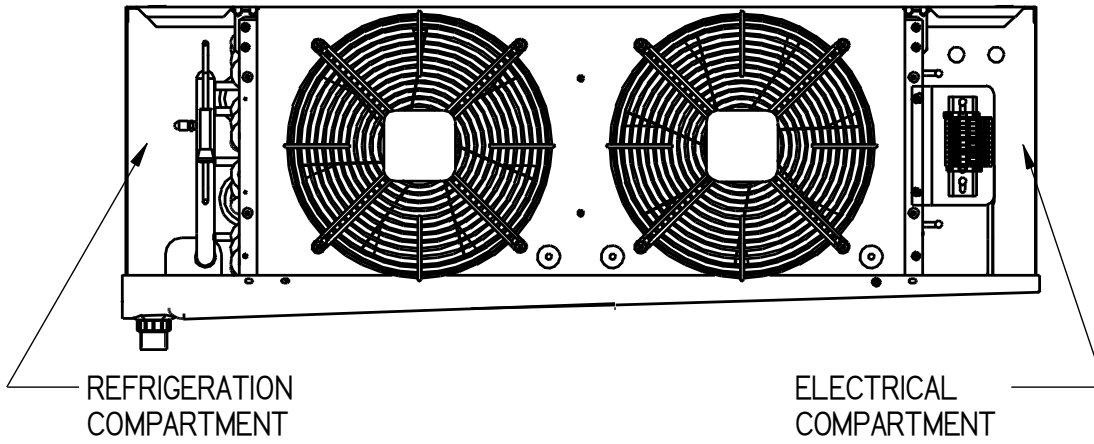

**COMMISSIONING NOTES**

UNIT SERIAL NUMBER

UNIT INSTALLATION/COMMISSIONING DATES