



PN: YAL0002-22-1
Issue: A
Date: 02/08/18

西克制冷(无锡)有限公司
Heatcraft Refrigeration (Wuxi) CO., LTD

NK 系列冷风机操作手册

NK Series Evaporator User Manual

感谢使用西克制冷（无锡）有限公司提供的“NK”系列冷风机产品。为了更好的使用您所购买的产品，请仔细阅读并按照下面的步骤操作，该手册仅适用于“NK”系列冷风机。

THANK YOU for purchasing the "NK Evaporator(s)" supplied by Heatcraft Refrigeration (Wuxi). Please read and apply the following procedures carefully in order to fully utilize the equipment you purchased. This user manual is only applicable to the NK series evaporators.

重要信息

IMPORTANT INFORMATION

调试蒸发器前请先参看“警告及安全防护”和“安装说明”这两部分
REFER TO THE SECTIONS ON
“WARNINGS AND SAFEGUARDS”, AND “INSTALLATION INSTRUCTIONS”
BEFORE ATTEMPTING TO COMMISSION THIS EVAPORATOR.

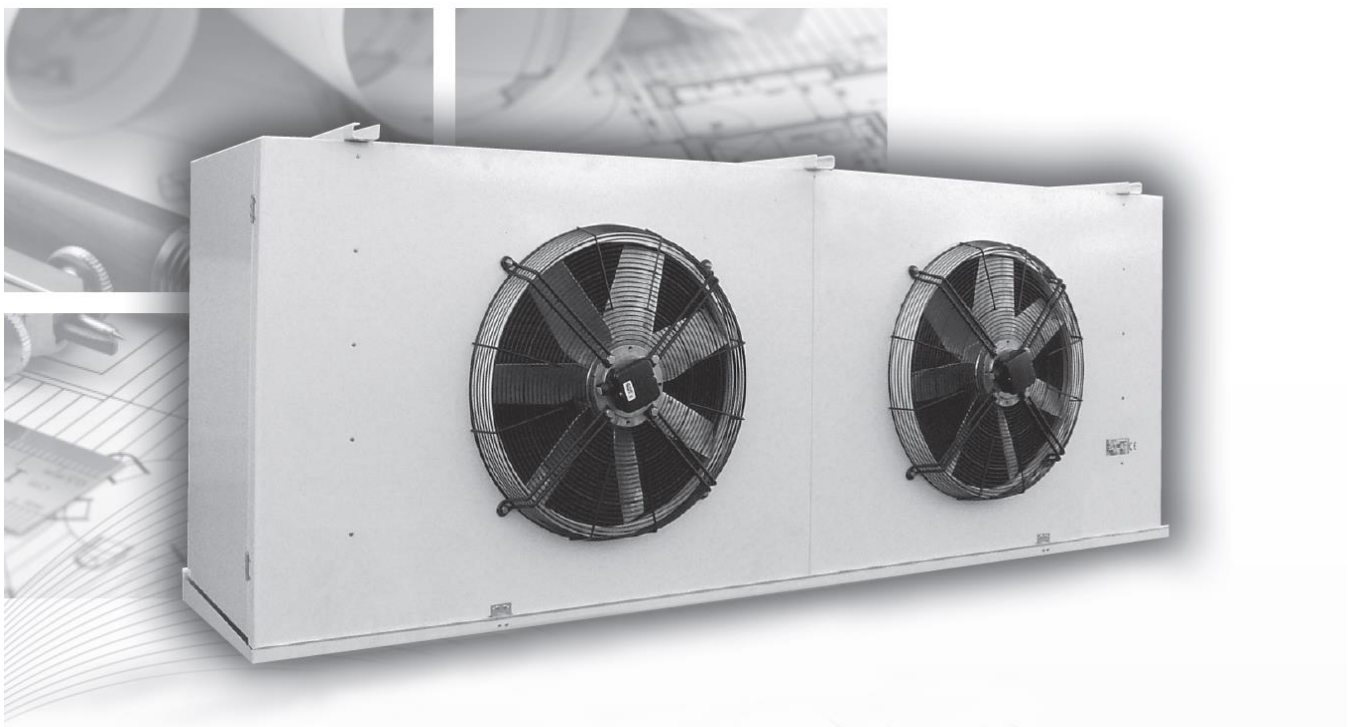

Contents 目录

Warnings and Safeguards 警告及防护.....	1
Purpose 用途.....	2
DIMENSION AND DATA 尺寸及参数.....	3
Installation Instructions 安装说明.....	6
General Commissioning Guide 调试指南.....	11
Routine Maintenance of Unit 设备的日常维护.....	12
ELECTRIC CONNECTION 电气接线.....	15



Warnings and Safeguards 警告及防护



Under no circumstances should anyone other than a qualified person attempt to gain access to the interior of the unit without first ensuring electric power is.

在没有保证切断电源前，除了具备资质的技工，其他任何人决不允许接触设备内部。

- Personal Protective Equipment such as gloves, eyewear and footwear should be used during any work carried out on this product.
- Installation, commissioning, testing, decommissioning and service maintenance should be performed only by qualified personnel who have sufficient knowledge in this type of equipment. It is the purchaser's responsibility to co- ordinate with qualified personnel as required.
- All units are pressurised with dry air or Nitrogen gas. Care must be taken to discharge the pressurised gas carefully prior to installing or commissioning the equipment.
- Avoid contact with sheet-metal edges and the coil fins. They can be sharp and are a potential personal injury hazard.

- 在操作该设备时应该配备个人防护用品，例如：手套、眼镜、鞋。
- 安装、调试、测试、关机和维修服务应该由对该类设备具有足够知识经验的有资质的人员（制冷机械工和/或电工）来操作。客户有职责配备操作的人员进行作业。
- 所有的设备都充有高压的干燥空气或者氮气。在设备安装或者调试前一定要小心的排放压缩气体。
- 避免接触钣金的边缘和盘管的翅片，锋利的边缘可能会引起人员受伤。

• Refrigerant can be harmful if it is inhaled and/or makes contact with exposed skin. Refrigerants used in this equipment are controlled substances, and must be used and recovered responsibly. It is against the law to deliberately discharge controlled substances into the environment. Extreme care must be taken when handling refrigerant, as personal injury or death may occur.

• 如果吸入和/或皮肤直接接触制冷剂都会造成伤害。该设备所用的制冷剂对人和环境都会造成危害，在使用和回收中必须要负责任。制冷剂排放到周围环境中是违法的。要非常小心的处理制冷剂，否则，可能发生人身伤害或死亡。

- All field wiring must conform to the requirements of the equipment and all applicable National and Local Codes. All power sources must be disconnected before the commencement of any service, maintenance or electrical work.
- Avoid contact refrigerant pipes and heat transfer surfaces when the equipment is operating. Their extreme hot or cold surfaces may result in skin burns.
- **WARNING:** Do not insert any object into operating fans. Ignoring this warning may result in personal injury and/or severe equipment damage and consequences.
- Fans operate continuously even when the refrigeration system has 'cycled off'. The exception is on freezer models where the fans will cycle off during defrost.
- Keep the floor of refrigerated rooms dry. Slippage due to ice formation on the floor is a potential personal Injury hazard.

- 所有现场接线必须符合设备的要求和通用的国家和地方编码。在任何维修服务或者电气操作之前必须先切断电源。
- 当设备在运行过程中避免接触制冷剂管道和 热交换表面。高温或低温的表面会导致您的皮肤受到伤害。
- **警告：**不要把任何物体插入运行的风扇中，否则会导致人员的损伤和/或机械的损害。
- 当制冷系统循环停止时，风扇会继续运转，除了在制冷模式下的除霜期间风扇会停止运行。
- 保持库房地面的干燥。潮湿的地面因为结冰而较滑，可能会造成人身伤害。

Purpose

These NK evaporator ranges are standard products of Heatcraft refrigeration (Wuxi), they comprise four types. They are intended for typical commercial sized cool room and freezer applications for the storage of vegetables, fresh meat, general foodstuffs, beverages, etc. They are not intended for environments that may have harmful, corrosive or flammable atmospheres or for the storage of corrosive or flammable chemicals. 'Marine' environments are considered corrosive; please consult Heatcraft before installing in this environment.

Standard Design Conditions

R and L type evaporators are designed at -8°C saturation suction temperature (SST) and 8 KTD to suit room temperature from -5°C to $+10^{\circ}\text{C}$ (refer to technical data for maximum and minimum allowed KTD for specific SST), for use in 'NK' commercial cool room applications. For rooms below 2°C , additional defrosting means may be required. R404A and R22 are recommended refrigerants. For other refrigerants, please refer to sales data sheet for capacity variations.

C and S type evaporators are designed at -25°C SST and 7 KTD. C type evaporators suit for room temperatures from -10°C to -25°C , S type evaporators suit for room temperatures from -10°C to -30°C (refer to technical data for maximum and minimum allowed KTD for specific SST), for use in 'NK' commercial freezer room applications. R404A or R22 are the recommended refrigerants. For other refrigerants, please refer to sales data sheet for capacity variations. For lower temperatures design variations may be required.

These standard evaporators cannot use Ammonia (NH_3) as refrigerant.

For special design requirements (non standard conditions and/or refrigerants such as Glycol, Hydrocarbons, etc), please inquire with your local representatives and/or Heatcraft Wuxi local branches, or call our national telephone number 0510-85282020 for your nearest available information resources

用途

NK 系列冷风机是西克制冷（无锡）有限公司的标准产品，产品共有四种类型。专为保存蔬菜，鲜肉，常规食品和饮料等典型的商业冷藏及冷冻库而设计。不能用于储藏有害，腐蚀，易燃物的冷库，也不能用于储藏腐蚀，易燃化学品的冷库。海洋环境是有腐蚀的，如果要安装在这样的环境中请在安装前咨询西克。

标准设计工况

R 和 L 型冷风机其设计的饱和吸气温度为 -8°C ，温差为 8K，适用于室温从 -5°C 到 10°C 商用冷库（特定的饱和吸气温度下允许的最大和最小温差请参照技术资料）。室温低于 2°C 时需额外的除霜方法。该蒸发器推荐使用的制冷剂有 R404A 和 R22。对于其他制冷剂，请参照数据表查不同的制冷量。

C 和 S 型冷风机其设计的饱和吸气温度为 -25°C ，温差为 7K，C 型适用于室温从 -10°C 到 -25°C 商用冷库，S 型适用于室温从 -10°C 到 -30°C 商用冷库（特殊饱和吸气温度允许的最大和最小温差请参照技术资料）。该蒸发器推荐使用的制冷剂有 R404A 和 R22。对于其他制冷剂，请参照数据表查不同的制冷量。更低的库温必须重新设计。

这些标准的蒸发器不能用氨 (NH_3) 作为冷媒。

对于非标设计（非标准工况和/或乙二醇、碳氢化合物等作为冷媒）请咨询西克当地代表和/或西克无锡，或者拨 0510-85282020 为您提供最新的信息。

DIMENSION AND DATA 尺寸及参数

Ø 630 mm, *Ø 630 mm: 400V/3/50Hz, Δ (1500 rpm) =1900 W max -- 3.20 A max ; Y (1000 rpm) =1200 W max -- 1.95 A max

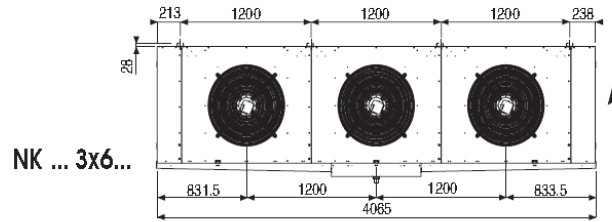
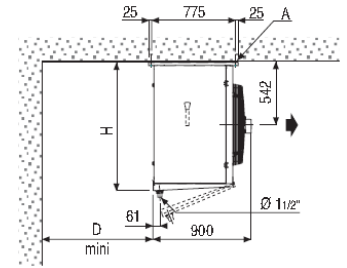
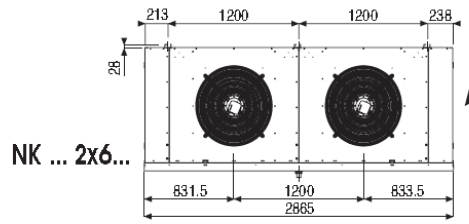
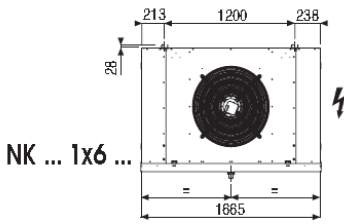

Vent.	D	H
1	550	1115
2	700	1115
3	800	1158
4	850	1158

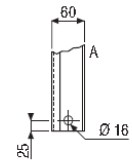
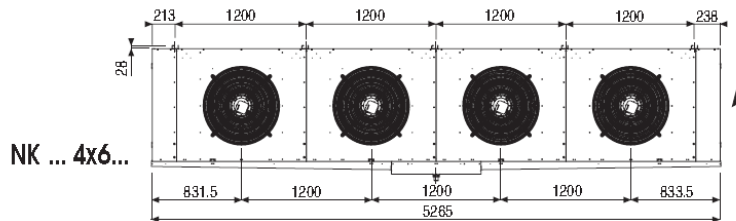

Ø 800 mm, *Ø 800 mm: 400V/3/50Hz, Δ (1000 rpm) =2000 W max -- 4.00 A max ; Y (750 rpm) =1250 W max -- 2.30 A ma

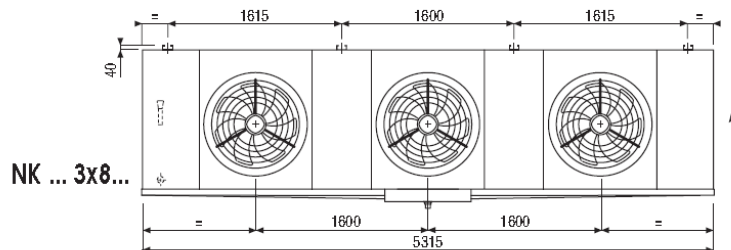
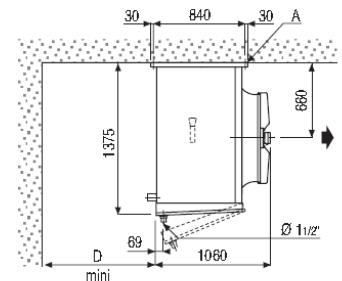
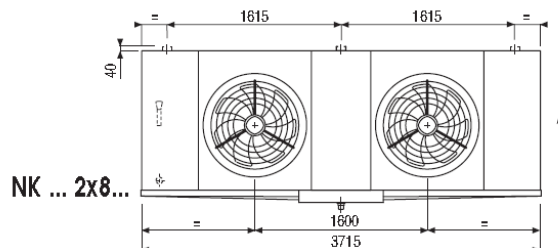
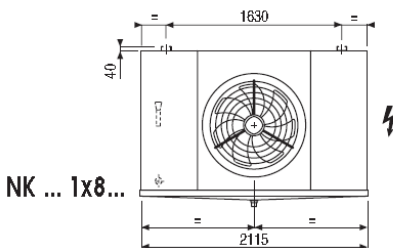

Vent.	D
1	700
2	900
3	1000
4	1050

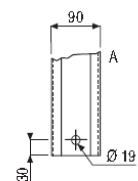
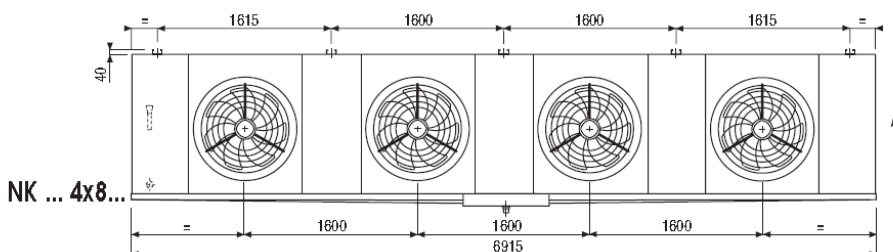

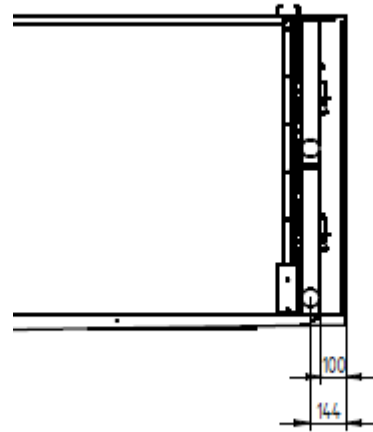
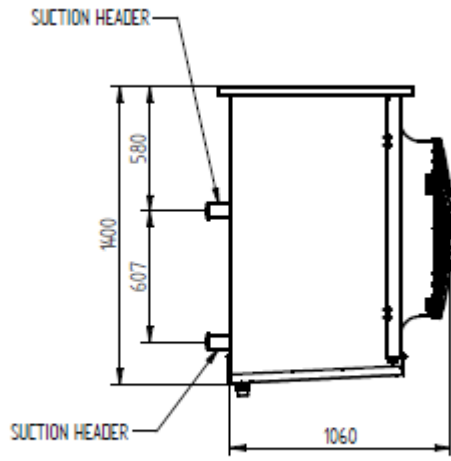

NKH 4X8D

NKH ... R - 4 mm

型号 Models	风扇数 X 扇径 Fan*Diameater	电除霜选项 (ELU 400V/3) Electric Defrost Option(ELU 400V/3)		接管尺寸 Connections		净重 Net Weight
		总功率 Power Total	总电流 Current Total	入口 Inlet	出口 Outlet	
		Num. *mm	W	A	inch	
1x6D B3 R	1X630	13800	19.9	1 1/8"	1 5/8"	200
1x8D C2 R	1X800	13500	19.5	1 3/8"	2 1/8"	270
2x6D B2 R	2X630	19800	28.6	1 3/8"	2 1/8"	300
3x6D B1 R	3X630	19500	28.1	1 5/8"	2 1/8"	370
2x8D C1 R	2X800	17400	25.1	1 5/8"	2 5/8"	420
2x8D C2 R	2X800	26100	37.7	1 5/8"	2 5/8"	480
3x6D B2 R	3X630	29250	42.2	2x1 3/8"	2x2 1/8"	430
4x6D B1 R	4X630	25800	37.2	2x1 5/8"	2x2 1/8"	480
3x8D C1 R	3X800	25800	37.2	1 5/8"	2 5/8"	570
4x6D B2 R	4X630	38700	55.9	2x1 3/8"	2x2 1/8"	550
4x6D B3 R	4X630	51600	74.5	2x1 5/8"	2x2 1/8"	630
3x8D C2 R	3X800	38700	55.9	2x1 5/8"	2x2 1/8"	670
4x8D C2 R	4X800	51300	74.0	2x1 5/8"	2x2 5/8"	840

NKH ... L - 6 mm

型号 Models	风扇数 X 扇径 Fan*Diameater	电除霜选项 (ELU 400V/3) Electric Defrost Option(ELU 400V/3)		接管尺寸 Connections		净重 Net Weight
		总功率 Power Total	总电流 Current Total	入口 Inlet	出口 Outlet	
		Num. *mm	W	A	inch	
1x6D B3 L	1X630	13800	19.9	1 1/8"	1 5/8"	190
1x8D C2 L	1X800	13500	19.5	1 3/8"	2 1/8"	260
2x6D B1 L	2X630	13200	19.1	1 3/8"	2 1/8"	260
2x6D B3 L	2X630	26400	38.1	1 5/8"	2 1/8"	330
2x8D C1 L	2X800	17400	25.1	1 5/8"	2 1/8"	400
2x8D C2 L	2X800	26100	37.7	1 5/8"	2 5/8"	460
3x6D B2 L	3X630	29250	42.2	2x1 3/8"	2x2 1/8"	410
3x6D B3 L	3X630	39000	56.3	1 5/8"	2 5/8"	460
4x6D B2 L	4X630	38700	55.9	2x1 3/8"	2x2 1/8"	530
3x8D C2 L	3X800	38700	55.9	2x1 5/8"	2x2 1/8"	650
4x6D B3 L	4X630	51600	74.5	2x1 5/8"	2x2 1/8"	600
4x8D C2 L	4X800	51300	74.0	2x1 5/8"	2x2 1/8"	800

NKH ... C - 6 mm

型号 Models	风扇数 X 扇径 Fan*Diameater	电除霜 (400V/3) Electric Defrost (400V/3)		接管尺寸 Connections		净重 Net Weight
		总功率 Power Total	总电流 Current Total	入口 Inlet	出口 Outlet	
		Num. *mm	W	A	inch	
1x6D B3 C	1X630	13800	19.9	1 1/8"	2 1/8"	210
1x8D C2 C	1X800	13500	19.5	1 3/8"	2 1/8"	280
2x6D B1 C	2X630	13200	19.1	1 3/8"	2 1/8"	290
2x6D B2 C	2X630	19800	28.6	1 5/8"	2 5/8"	320
2x6D B3 C	2X630	26400	38.1	1 5/8"	2 5/8"	360
2x8D C1 C	2X800	17400	25.1	1 5/8"	2 5/8"	440
3x6D B2 C	3X630	29250	42.2	2x1 3/8"	2x2 1/8"	460
3x6D B3 C	3X630	39000	56.3	2x1 5/8"	2x2 1/8"	520
3x8D C2 C	3X800	38700	55.9	2x1 5/8"	2x2 5/8"	700
4x6D B3 C	4X630	51600	74.5	2x1 5/8"	2x2 5/8"	670

NKH ... S- 9 mm

型号 Models	风扇数 X 扇径 Fan*Diameater	电除霜 (400V/3) Electric Defrost (400V/3)		接管尺寸 Connections		净重 Net Weight
		总功率 Power Total	总电流 Current Total	入口 Inlet	出口 Outlet	
		Num. *mm	W	A	inch	
1x6D B3 S	1X630	13800	19.9	1 1/8"	2 1/8"	210
2x6D B1 S	2X630	13200	19.1	1 3/8"	2 1/8"	280
1x8D C2 S	1X800	13500	19.5	1 3/8"	2 1/8"	280
2x8D C1 S	2X800	17400	25.1	1 5/8"	2 5/8"	430
2x6D B3 S	2X630	26400	38.1	1 3/8"	2 5/8"	360
2x8D C2 S	2X800	26100	37.7	1 5/8"	2 5/8"	480
3x6D B2 S	3X630	29250	42.2	2x1 3/8"	2x2 1/8"	450
3x8D C1 S	3X800	25800	37.2	1 5/8"	2 5/8"	590
3x6D B3 S	3X630	39000	56.3	2x1 3/8"	2x2 1/8"	510
3x8D C2 S	3X800	38700	55.9	2x1 5/8"	2x2 1/8"	670
4x6D B3 S	4X630	51600	74.5	2x1 5/8"	2x2 5/8"	640
4x8D C2 S	4X800	51300	74.0	2x1 5/8"	2x2 5/8"	860



Installation Instructions

安装说明

a) Lifting of Unit

The weight of the unit ranges from 190 to 860kg. Always use the appropriate mechanical handling equipment to lift the unit into place.

b) Unpacking of Unit

When unpacking, check for any damage to packing material or the unit itself, which may affect the unit's performance. If any such damage is evident, please contact your Heatcraft branch.

c) Mounting the Unit

These evaporators can be mounted with threaded rods and bolts. Please refer to the page 10, select suitable threaded rods and bolts. It is the installer's responsibility to ensure the evaporators mounted securely and professionally.

To comply with HACCP and/or relevant regulations for food safety, the area above the evaporator must be sealed or exposed in such a way to facilitate hand cleaning without the use of tools. So depending on the end user's preference, the evaporators can be installed either,

- Using threaded rod and allow sufficient

Space between the top of the evaporator and the ceiling for cleaning, or

- Flush mount the evaporator to the ceiling, Seal the gap between the top and the ceiling with food benign sealant to prevent accumulation of any foreign matter.

All evaporators shall be mounted professionally and levelled properly so that condensate drains from the evaporator efficiently. Adequate support must be provided to hold the weight of the evaporator plus the weight of the refrigerant and any frost that may accumulate on the coil surface. The use of weight lifting equipment is highly recommended whenever possible.

d) Condensate Drain Line

Ensure that the installation complies with HACCP and/or relevant regulations for food safety, and the end user's preferences when choosing copper, stainless steel or PVC material for condensate drain lines. For low temperature applications, proper insulation and heating cable shall be provided to prevent the drainpipe from freezing. Provide a minimum 300mm per meter pitch to condensate drain lines for proper drainage. Drain lines should be at least as large as the evaporator drain connection. All condensate drain lines must be trapped to prevent outdoor air and odours entering the refrigerated room, and must never be connected directly to the sewer system. All traps must be located in a warm ambient to prevent water from freezing. It is recommended that the drain line be kept to a minimum length within the refrigerated room.

a) 设备的吊装

设备的重量在 190~860kg 之间，用合适的设备吊起到适当的位置。

b) 包装的拆除

拆包装的时候，检查设备和包装材料是否受损，任何受损可能会影响运行效果。如果发现有明显的受损部位，请您联系西克各地办事处。

c) 设备的安装

冷风机可以用螺栓和螺母固定。请参考第 10 页，选择合适的螺栓和螺母，安装人员有责任确保蒸发器安全的、专业的安装在指定位置。

为了遵守 HACCP 和/或有关的食物安全标准，蒸发器的上面必须密封，或者不密封的话请留出一定的空间方便手工清洗。以上两种方式根据终端用户的实际需要而定。

- 用螺栓固定蒸发器，并在顶板到天花板之间留出足够的空间以便于清洗。

- 将冷风机对齐安装在天花板上，采用适用于食品的密封材料密封天花板和冷风机顶部间的空隙。

冷风机安装要得当，位置要适中，以保证凝结水能有效地排出冷风机。支撑必须有足够的力量承受冷风机自身的重量，充注的制冷剂重量及盘管表面寄居的霜的重量。可能的话推荐使用起重设备来吊装。

d) 排水管

请确认排水管的安装符合食品的安全规范，材料可选择铜管，不锈钢管或 PVC 管，根据客户而定。对低温应用工况，需提供保温及加热丝以防止排水管结冰。推荐每 1 米 300mm 的坡度正确安装排水管。排水管的尺寸至少和冷风机的积水盘接头一样。所有的凝结水排水管必须要安装 U 型弯以防止外界空气及异味进入冷库，绝对禁止直接和排污系统相连。所有 U 型弯置于温暖的环境以防止结冰。建议排水管在冷库内的长度要尽可能短。

e) Refrigerant Distributor and Nozzle

To obtain the best performance of the evaporator, the distributor body shall be mounted vertically to ensure refrigerant liquid being distributed evenly to all the circuits.

For each unit through the whole range of NK series evaporators, a carefully selected Sporlan-type orifice will be factory-fitted in the distributor based on your request of refrigerant type before delivering the completed unit to your preferred site.

f) TX Valve, Sensor Bulb and Equalisation Line

For best performance, the TX valve should be installed as close to the distributor as possible.

Locate the TX valve sensor bulb on the horizontal section of suction line and close to the suction header. For a satisfactory TX valve operation, good thermal contact between the sensor bulb and the suction line is essential. Follow TX valve manufacturers recommendations when positioning TX valve and sensor bulb. Incorrect installation may result in poor evaporator performance.

The external equalisation line should be used to link the TX valve external equalisation port and the suction line, near the suction header. A 1/4" tube brazed to the suction line is supplied for that purpose.

g) Refrigeration Piping

Refrigeration piping work shall be carried out professionally by qualified refrigeration mechanics in accordance with applicable national and local regulations and in conformance with good engineering practices required for the proper operation of the refrigeration system

All the evaporators supplied by Heatcraft Wuxi are supplied clean and internally charged with dry nitrogen to prevent oxidation and ingress of moisture or foreign matter. Care shall be taken during installation of the piping to prevent entrance of foreign matter or moisture by minimising the time that the piping is uncapped.

The interconnecting refrigeration pipe size is not necessarily the same size as the outlet on the unit. The pipe sizes shall be selected/calculated based on the best compromise of minimizing refrigerant pressure drop and refrigerant velocity to ensure efficient oil return.

Horizontal suction lines shall slope away from the evaporators to allow the oil return freely to the compressor by gravity. A 1:100 slope is considered sufficient. It is a good engineering practice to fit an oil trap when the suction line rises above the evaporator.

e) 制冷剂分液器及节流环

为保证冷风机达到最佳的制冷效果，分液器必须竖直安装，确保制冷剂均匀地分配到各个制冷回路中。对于 NK 系列冷风机中每一个型号，在发往客户指定的地点前，根据客户所采用的制冷剂，我司已在工厂安装了和分液器配套的 Sporlan 孔板。

f) 热力膨胀阀, 感温包及外平衡管

为了达到最佳的制冷效果，热力膨胀阀应尽可能安装在离分液器近的位置。

将热力膨胀阀的感温包放置在吸气管的水平位置，并且离吸气集管比较近的位置。为了达到良好的运行效果，必须保证感温包和吸气管之间达到良好的热接触。热力膨胀阀及感温包的放置请遵循生产厂家的指示。不正确的安装会导致制冷效果变差。

外平衡管用于连接热力膨胀阀的外平衡口和吸气集管附近的吸气管。连接到吸气管的 1/4 英寸铜管就是所说的外平衡管。

g) 制冷管路

制冷管路的设计，安装必须由专业的制冷技工依照国家和当地的规范，同时符合良好的制冷工程运行实际。

西克提供的所有冷风机都是干净的，并且内部预先充注有干燥氮气以防止氧化及湿气和外界杂质进入。在安装时，尽量减小接管暴露在空气中的时间，以防止外界杂质和湿气的进入。

水平吸气管需以一定的倾斜度离开冷风机，确保冷冻油由重力作用回到压缩机。1:100 的斜率是足够的。当吸气管高于冷风机时，最好安装回油弯。

LOCATION UNIT COOLER AND PIPING 安装位置及接管

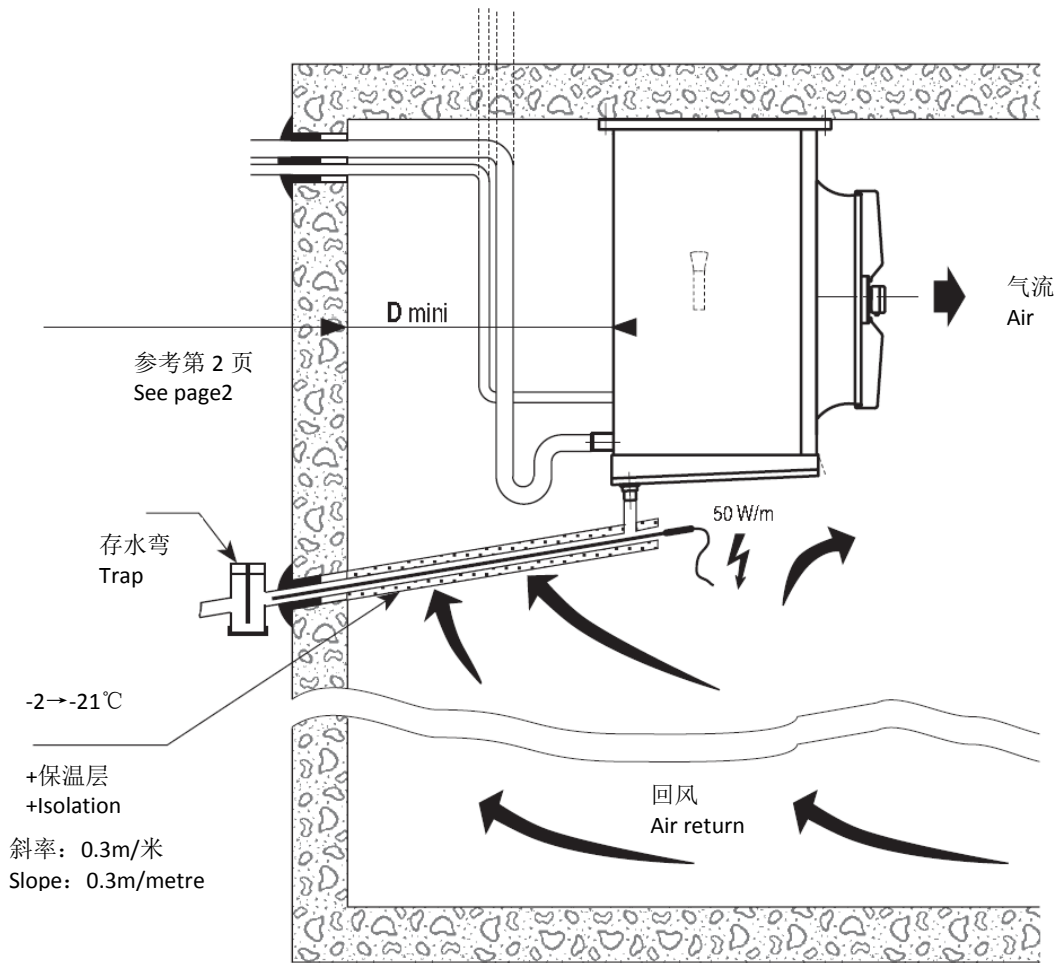

BULB AND EXTERNAL EQUALIZER LAY-OUT 感温包和外平衡管布置

① → ②

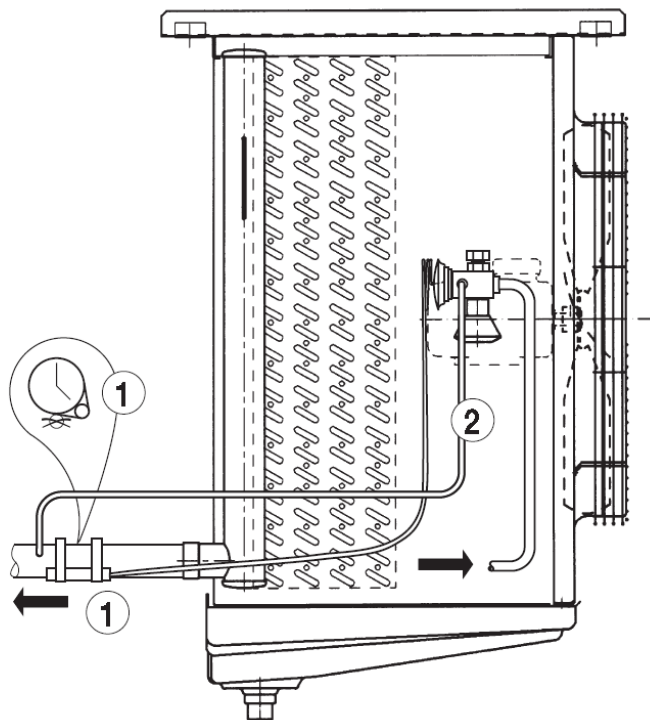

FITTING TO CEILING 吊装到库顶

① → ② → ③ → ④ → ⑤

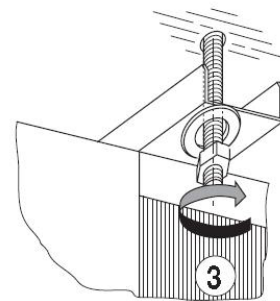
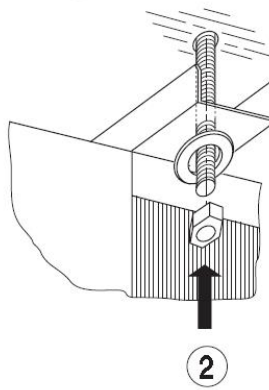
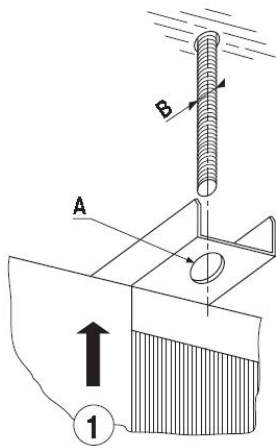
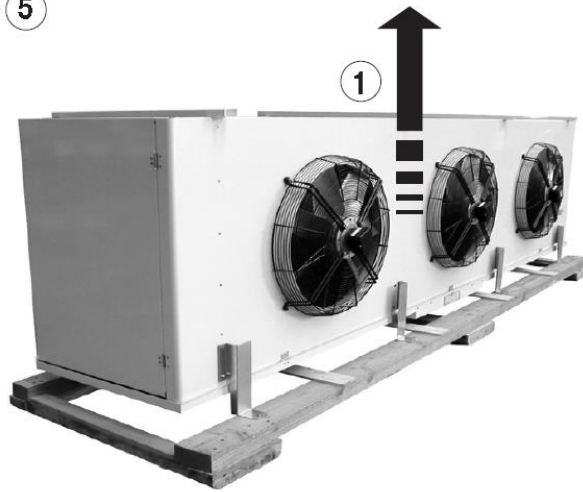

	A	B
Ø 630 mm	16 mm	M14
Ø 800 mm	19 mm	M16

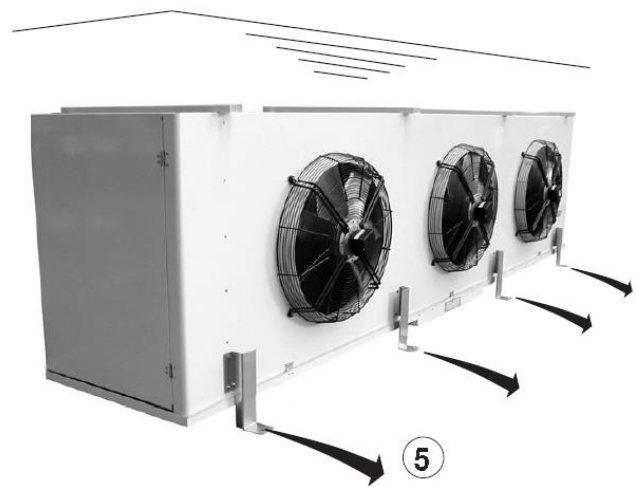
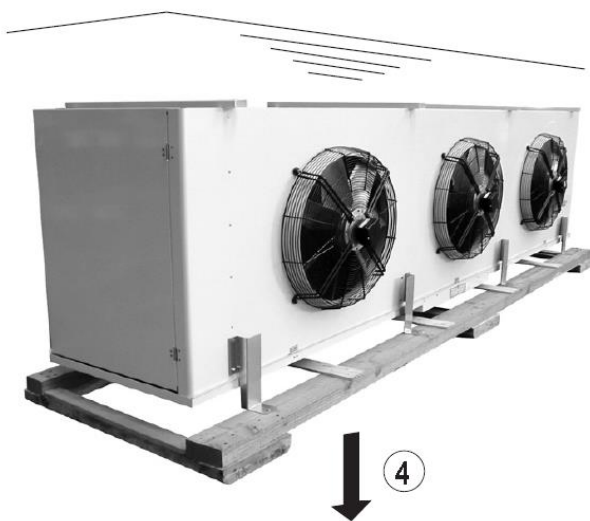

T.E.V. MOUNTING 安装膨胀阀

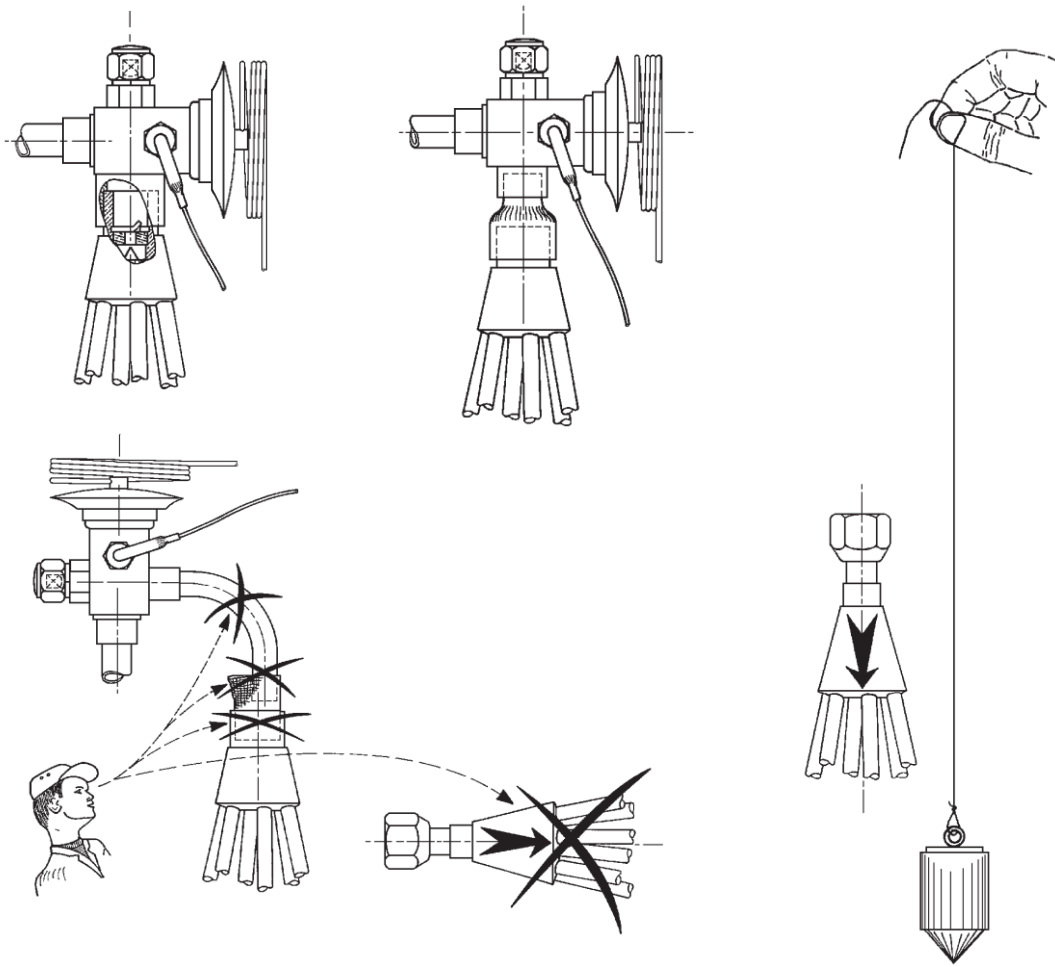

REFRIGERANT PIPING 制冷管路

① → ②

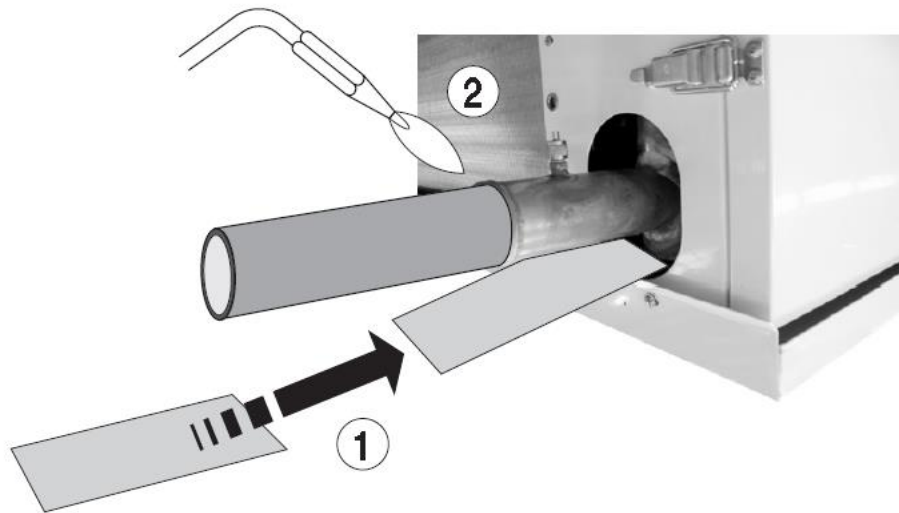



All electrical connections must be carried out by a licensed electrical technician and in accordance with the relevant regulations. Without prior permission from Heatcraft Wuxi, all the provided electrical wiring shall NOT be modified. Failure to follow this procedure may cause death and void warranty.

所有电器连接必须遵循相应的规范，并由专业的电气技工来实施。未得到西克认同的情况下，不允许修改电气连接。若不遵循该要求，将会导致人身伤害，并且我司也将因此不提供任何质保。

The R and L with ELU option models, and the C and S models, the evaporators fitted with heater elements, the evaporators are supplied pre-wired in the electrical box of the evaporator. The wiring diagram for each pre-wired evaporator is located on the inside of the electrical box cover. Refer to the sales data sheets for all the information regarding voltage and current for fan motors and element heaters.

R 和 L 类带 ELU 选项的型号，C 和 S 类的型号，蒸发器都预装有电加热器，加热器的线都预先接入产品的电控盒里。每个预先接好线的冷风机的电气接线图放在接线盒的盖子内。对于风扇马达和电热丝的信息请参看样本。

During field wiring, fan motors shall be wired up in delta connection. After electrical installation, units should be tested for correct current draw and rotation of fan motors.

在现场接线时，风扇马达采用三角形连接。电气接线完毕后，请检查电流及风扇马达的运转方向是否正确。

General Commissioning Guide

调试指南

Refrigeration system commissioning shall be carried out professionally by qualified refrigeration technicians in conformance with good engineering practices required for the proper operation of the refrigeration system.

制冷系统的开机调试需符合正确的制冷运行实际，由有资质的制冷技工操作。

After all installation and electrical work is completed, the entire refrigeration system must be leak tested. After satisfactory testing the refrigeration system, then necessary refrigeration lines shall be insulated. The insulation located in outdoor environments shall be protected from UV exposure.

在所有的安装和电气连接完毕后，整个制冷系统需先检漏，确认系统无泄漏后，所有的制冷管路需保温，室外的保温同时需满足防止 UV 暴晒。

Before charging the refrigerant, the entire refrigeration system shall be evacuated by connecting a good, high vacuum pump to both the high-pressure side and low-pressure side service valves or ports.

在充注制冷剂前，必须在高压侧和低压侧的维修阀件处连接高性能的真空泵对整个系统抽真空。

Vacuum must be maintained sufficiently so as to minimise the occurrence of leaks when the system is charged. Refrigerant must not be charged into a system with known leaks. Should vacuum not be maintained, check for leaks with Nitrogen gas at a suitable pressure prior to charging.

系统必须维持足够的真空度，这样在充注制冷剂时不会出现泄漏现象。如果系统已有泄漏，决不允许再充注制冷剂。如果系统不能保持真空状态，那么在充注制冷剂前，用氮气在一定压力下检漏。

Installing a liquid line drier and a sight glass in a refrigeration system is sound engineering practice. The liquid line drier will ensure all refrigerant supplied to the refrigeration system is clean and dry. The sight glass is a useful device to ensure sufficient refrigerant is supplied to the refrigeration system.

Refrigerant charging shall be in liquid form at the high-pressure side of the system such as condenser or liquid receiver. If the refrigerant charging must be carried out through the suction side of the compressor, charge in vapour form only.

Double-check all field wiring connections and factory terminals. Factory connections can vibrate loose during shipment. Ensure correct fan motor rotation, airflow is induced from coil side and forced out of fan motor side.

Check the room thermostat for normal operation and adjust if necessary.

In order to maximise efficiency and airflow, should adjust the defrost minutes and defrost times according to the practical situation.

Routine Maintenance of Unit

All Heatcraft Evaporators are designed to have low service maintenance requirements. Based on normal operation conditions and working environment, a service maintenance schedule shall be established after the successful completion of commissioning, to ensure the evaporators operate efficiently and running costs are kept at a minimum. The following items shall be checked and recorded during service maintenance,

- Visually inspect the evaporators looking for corrosion, unusual vibrations, oil stains and drain tray blockage. The drain tray should be cleaned regularly with warm soapy water.
- Clean the evaporator fins by using a soft brush, low pressurized (Max 3bar) water and/or commercially available evaporator coil cleaner. Never use an acid based cleaner. Follow label directions for appropriate use. Flush and rinse coil until no residue remains.
- Check that each fan rotates freely and quietly, fan guards are free of airflow obstructions and fan screws are tight.
- Inspect electrical wiring, connections and components looking for damaged wiring, loose connections and worn components.
- Check that all coil heaters are in their original positions and properly secured, and that drain tray heater is in proper contact with the tray and located by the brackets.
- Ensure even coil frost formation pattern on the air off (fan) side of the coil during operation. An uneven frost pattern may indicate a distributor blockage or incorrect refrigerant charge. The air on side tubes may contain superheated vapour and may not frost completely.

制冷系统中安装液路干燥器和视液镜是比较好的工程应用。液路干燥器可以确保系统中的制冷剂是干净及干燥的。视液镜用来检查系统中是否有足够的制冷剂。

采用液态制冷剂进行充注，一般在系统的高压侧，比如在冷凝器或储液器。如果必须在压缩机的吸气侧进行充注，必须以气态的方式充注。

由于运输可能导致工厂接线松动，请再次确认出厂前的接线及现场的接线。检查风扇马达的运转方向是否正确，气流是否是从盘管处吸入，从风机侧排出。

检查库房的温控器是否运行正常，有必要时可对参数进行调整。

为了能使客户在使用我公司蒸发器时得到最高的效率和最大的风量，应该根据实际情况调整除霜时间和除霜次数。

设备的日常维护

所有西克冷风机都是基于维护较少的前提下设计的。根据正常的运行工况和环境，在调试成功后，应准备一份维护时间表，以确保冷风机在最佳效率下运行，同时保证运行成本最低。在做维护时，请检查并记录下列各项参数：

- 检查冷风机是否有腐蚀，不正常的振动，油堵及排水管脏堵。排水管需要经常用温肥皂水清洗。
- 用柔软的刷子清洗冷风机翅片，用低压（最大 3bar）清水冲洗盘管或者用市面上买得到的盘管清洗器。禁止使用酸性清洗剂。请遵循标识的使用指南。冲刷盘管直至无任何残留物。
- 检查每个电机风扇转动是否正确，风扇罩是否有堵塞，螺栓是否拧紧。
- 检查电线，接头及其他元件是否有电线损坏，接线是否松动，元件有无磨损。
- 检查所有的盘管加热丝是否在原始位置，是否安装牢固，检查积水盘管的电加热丝是否和托盘接触良好，位置是否在托架上。
- 在运行时检查在排风侧盘管上的结霜是否均匀。不均匀的结霜说明分液头有堵塞物或者制冷剂充注的不正确。在吸风处的盘管上可能因为有过热气体而无任何结霜现象。

- Look for abnormal accumulation of ice patterns and adjust the defrost cycles accordingly.
- Check the superheat and adjust TX valve accordingly.

- 寻找不正常的结霜状况，根据情况调整除霜 循环。
- 检查过热度，相应的调整热力膨胀阀。

All power must be disconnected before cleaning and/or service maintenance. The condensate drain tray also serves as a cover of hazardous (hot, cold, electrical and moving) parts. Operation of evaporators without condensate drain tray constitutes a safety hazard.

在清洗和维修时必须断电。积水盘也是 需要维修的部件(热，冷，电气及运动部 件)。如果冷风机在不安装积水盘情况下 运行是存在安全隐患的。

The service maintenance record as well as this “NK Evaporators User Manual” shall be kept together in a safe place as a future

维护记录和”NK 型冷风机的操 作手册” 应好好保管以 便将来做参考。

General Decommissioning Guide

关机指南

In order to remove the evaporator from its mounting place, the following procedures need to be carried out professionally by qualified personnel. Failure to do so may result in personal injury or death, property damage by fire or explosion. Discharge of refrigerant to atmosphere is illegal and may result in heavy fines by relevant regulatory authorities.

将冷风机从原来的安装位置移走，必须由专业 的制冷技工遵循下面的程序来进行拆卸。不遵 循该程序将引起操作人员受伤或死亡，并且由 于失火或爆炸引起财产损失。直接将制冷剂排 放到大气中是不合法的，并且会受到监控部门 的严厉罚款。

- Pump down the entire refrigerant charge into the liquid receiver or appropriate container such as reclaim cylinder, and shut related valves. All reclaimed refrigerant that is not re-used must be taken to an approved refrigerant recycling or destruction facility.
- Disconnect the power supply. Remove all necessary field electrical wiring and related components, leaving the earth wire to the last.
- Disconnect the drainpipe.

- 将全部充注的制冷剂抽到储液器或合适的储 液罐，如回收钢瓶，同时关闭相应的阀件。所 有回收的不能再用的制冷剂必须送往合格的制 冷剂再利用或销毁处。

- 切断动力供电。移走所有不要的现场接线， 相应的电气元件，最后切断地线。

- 断开排水管。

- Care must be taken when de-pressing the Schrader valve core in order to balance the pressure between the evaporator and ambient. There may be a small amount of refrigerant trapped in the oil, the pressure rise in the evaporator will boil and vaporise the refrigerant resulting in a potential personal injury hazard.
- Cut and solder seal the refrigeration liquid line and suction line pipe connections.
- Remove the evaporator from its mounting place. Adequate support must be provided to hold the weight of the evaporator. The use of weight lifting equipment is highly recommended whenever possible.

atmosphere. Reclaim all used refrigerants.

Heatcraft Wuxi is dedicated to providing safe products and protecting the environment by complying with all applicable national laws and regulations governing environmental protection. New and used refrigerants cannot be vented into

- 为了平衡蒸发器和外界的压力，在打开针阀 阀心时必须特别小心。在润滑油中溶有一定量 的制冷剂，当冷风机的压力上升时制冷剂就会 沸腾并挥发，这可能会导致人员受伤。

- 切断，并密封液管和气管的接头。

- 将冷风机从安装位置移走。当需要时，建议 采用起

重设备。

西克制冷致力于提供安全，并且符合 国家法律及环境保护法规的制冷产 品。新的或者使用过的制冷剂是不可 以直接排放到大气中的，回收所有使用过的制冷剂。

ELECTRIC CONNECTION 电气接线

FANS 电机

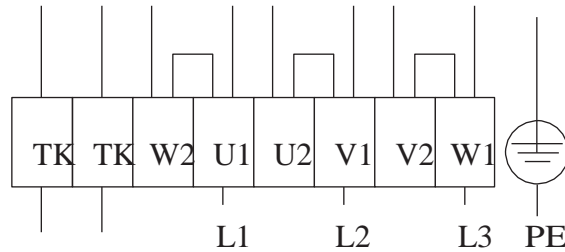

Δ: 连接 Δ: CONNECTION

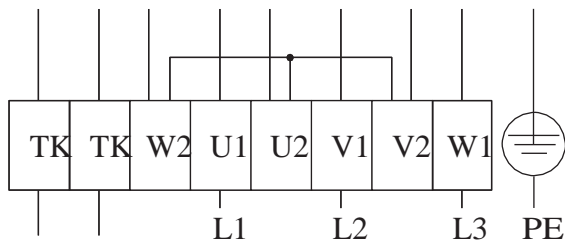

Y: 连接 Y: CONNECTION

Take note of name plate data-请注意铭牌数据!

ELECTRIC HEATERS 电加热器

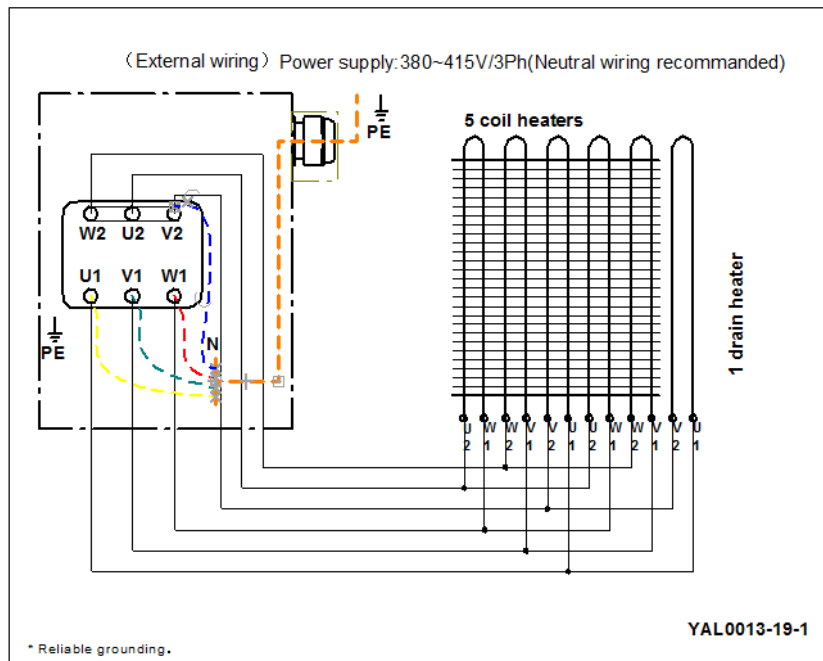

5 盘管加热器+1 排水盘加热器
5 Coil Heaters + 1 Drain Pan Heater

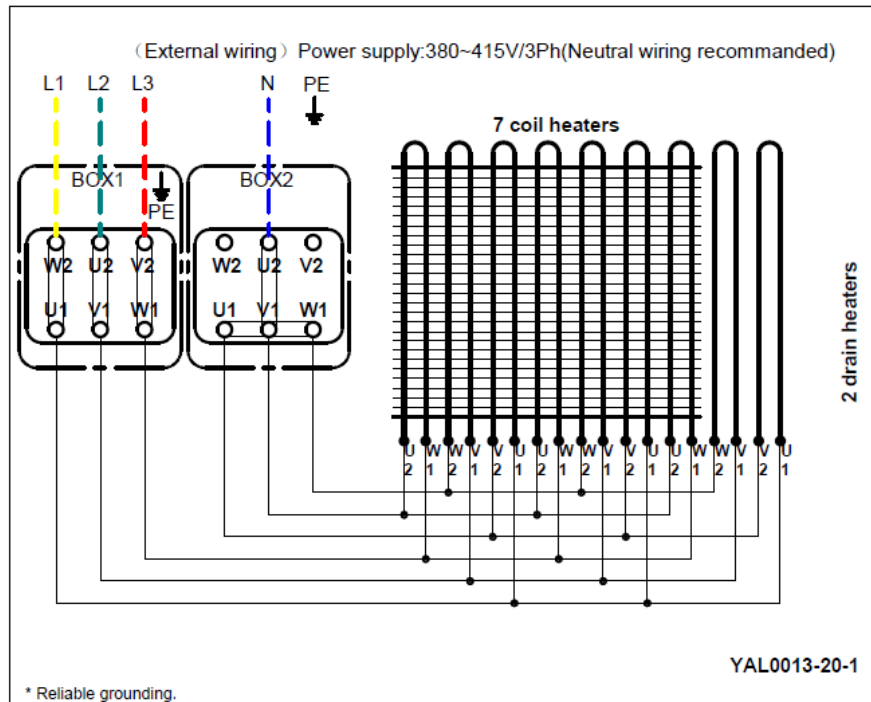

7 盘管加热器+2 排水盘加热器
7 Coil Heaters + 2 Drain Pan Heaters

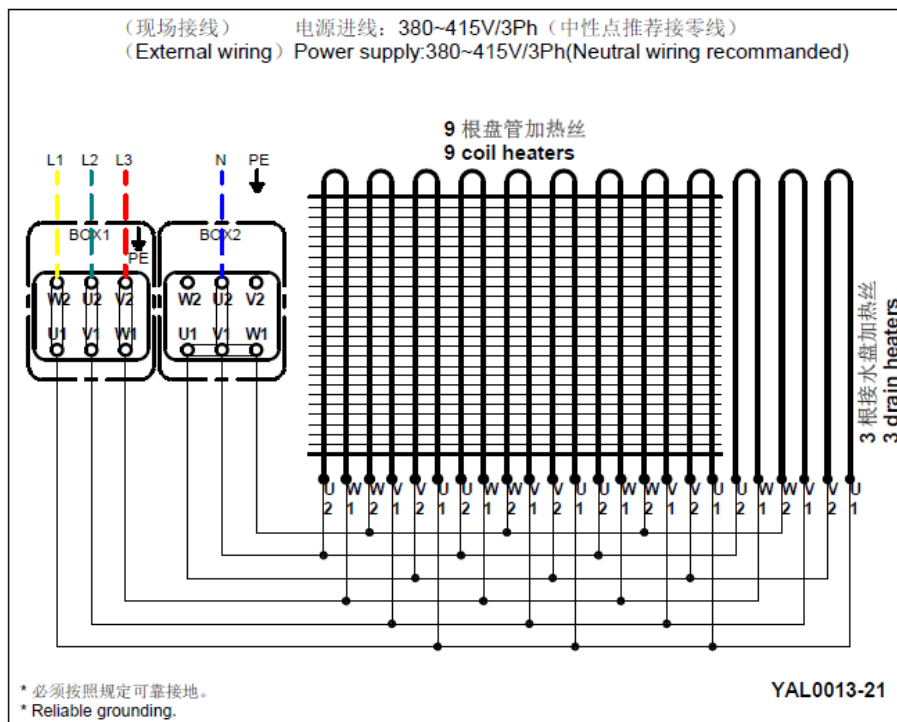

9 盘管加热器+3 排水盘加热器
9 Coil Heaters + 3 Drain Pan Heaters

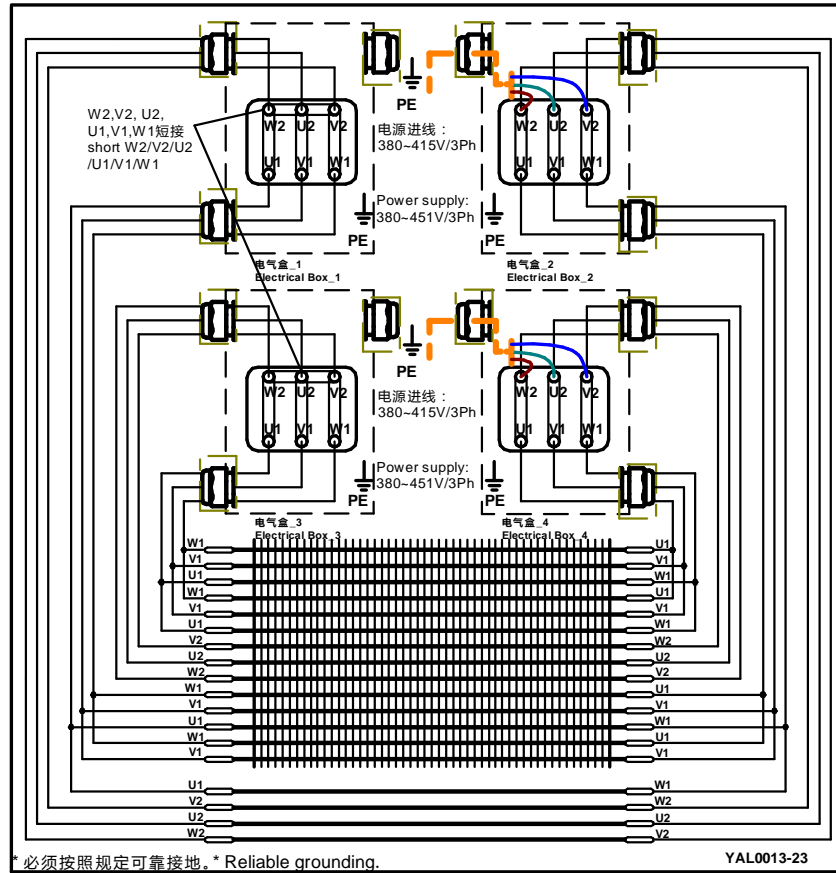

14 盘管加热器+4 排水盘加热器
 14 Coil Heaters + 4Drain Pan Heaters

CMU MOTORS FACTORY WIRED OPTION/CMU 电机工厂预接线可选项

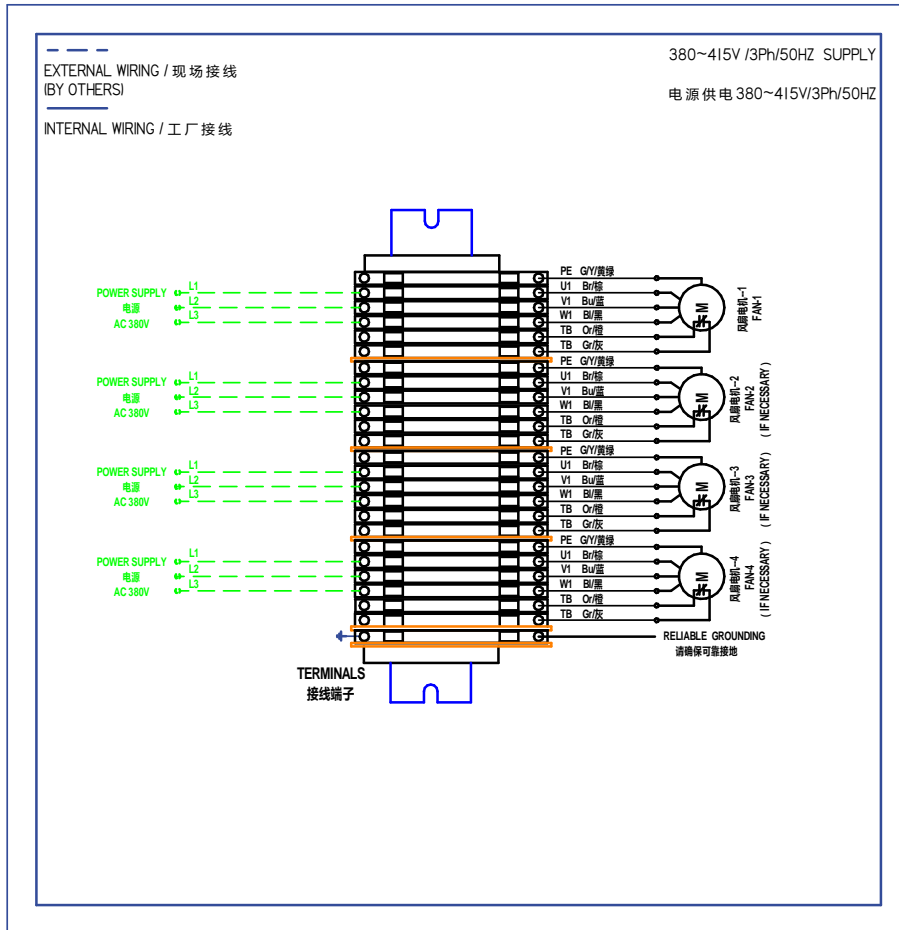

RVU FAN PANEL ELECTRICAL HEATERSOPTIO/RVU 风扇面板加热丝可选项

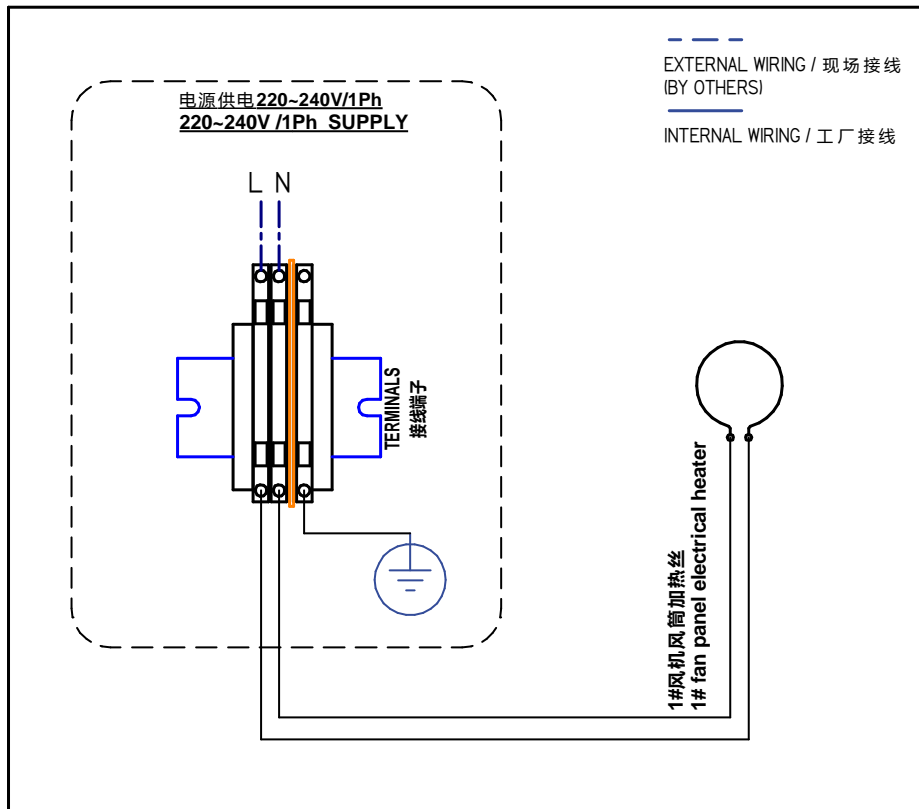

1 风扇/1 FAN

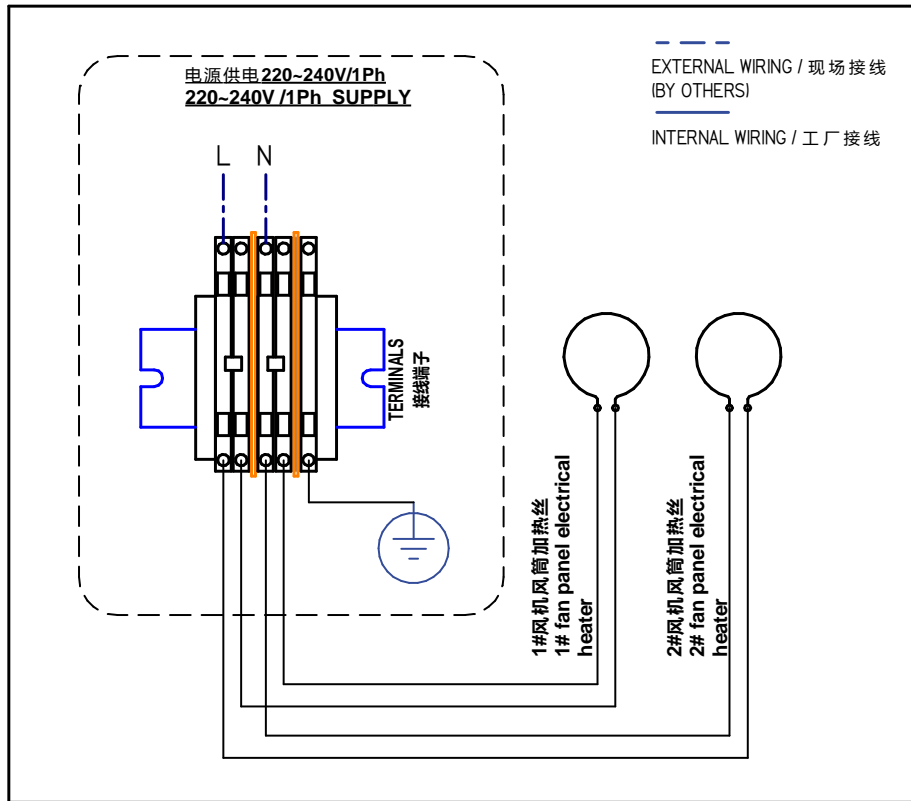

2 风扇/2 FANS

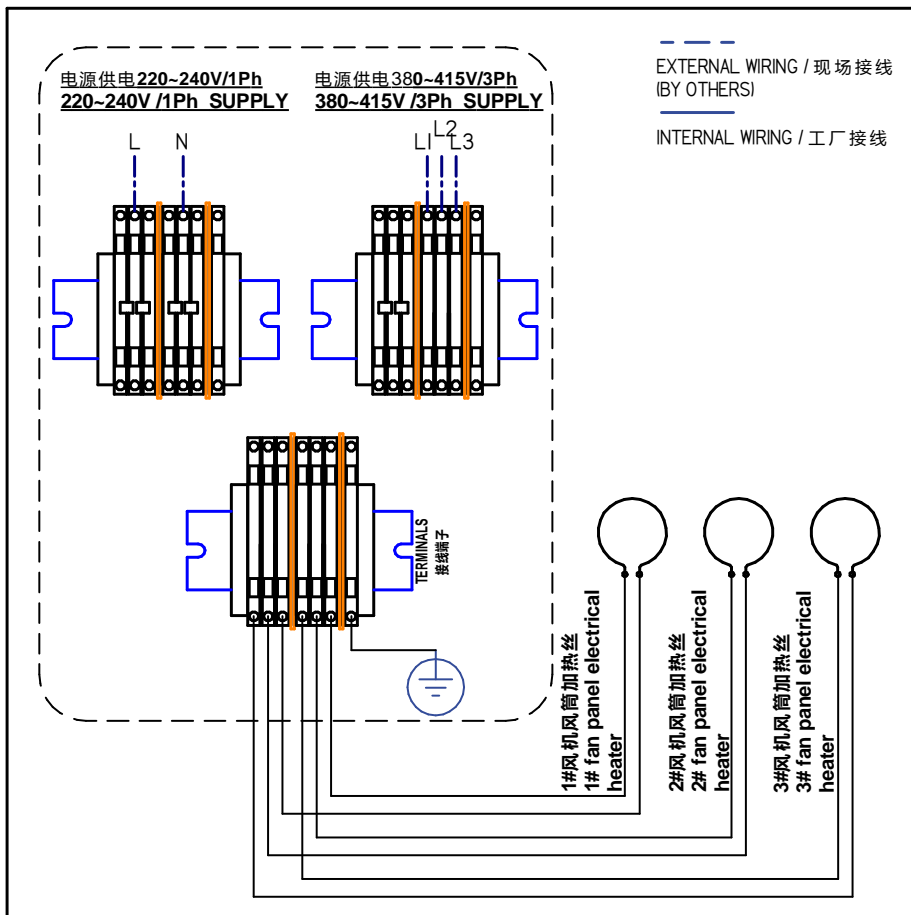

3 风扇/3FANS

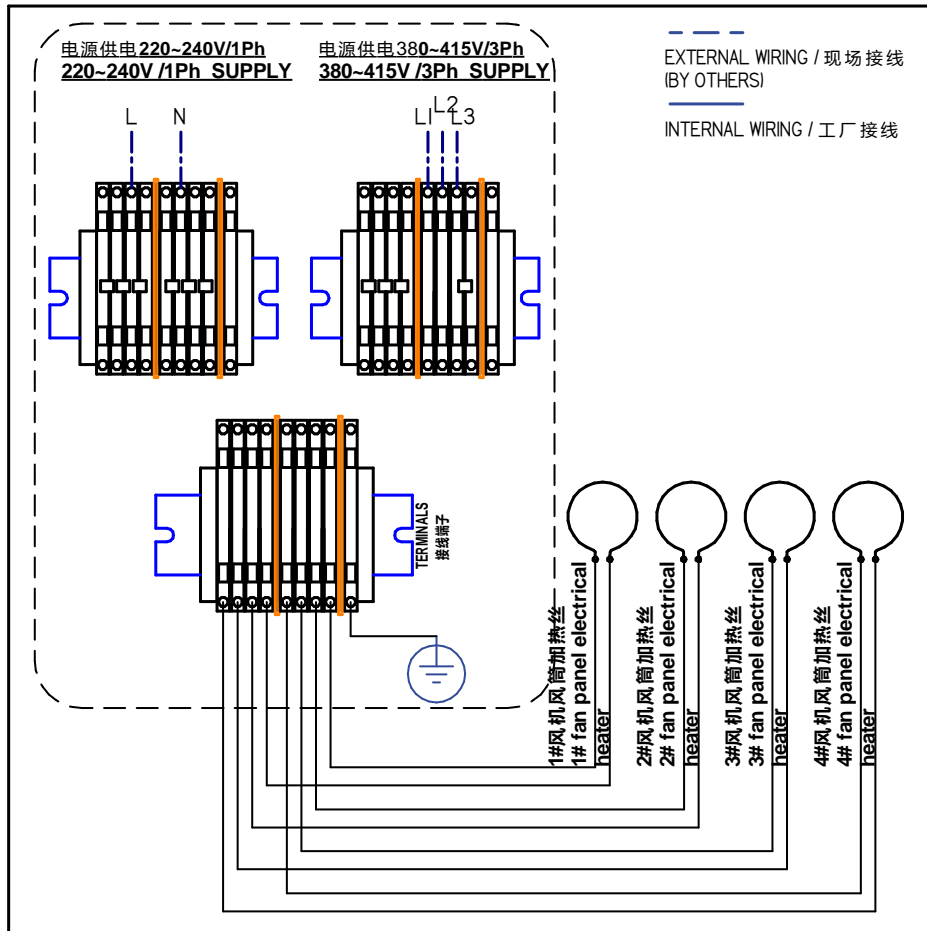

4 风扇/4FANS

Heatcraft reserves the right to alter its products without notice, more information please contact with sales and visit Heatcraft Asia website.

西克环球制冷亚洲有限公司对手册中出现的各类技术参数保留自行更改而不事先通知的权利, 保留此手册的最终解释权, 更多信息, 请联系销售人员或西克制冷亚洲网站

<http://www.heatcraftasia.com>

HeatCraft Refrigeration (Wuxi) CO., LTD
西克制冷（无锡）有限公司



No.12 Xindu Road, Wuxi Singapore Industrial Park, Wuxi
Tel: 0510-85282020; Fax: 0510-85282242
江苏省无锡市新加坡工业园区新都路 12 号
电话: 0510-85282020; 传真: 0510-85282242