

INSTALLATION MANUAL **AIR COOLED CONDENSING UNITS**

for DORIN semi-hermetic units from 0.8 to 4 hp

THANK YOU FOR CHOOSING THE KIRBY **COMMANDER** CONDENSING UNIT WITH **DORIN SEMI-HERMETIC** COMPRESSORS
TO ENSURE TROUBLE FREE INSTALLATION AND COMMISSIONING, PLEASE REFER TO THE CONTENTS OF THIS HANDBOOK.

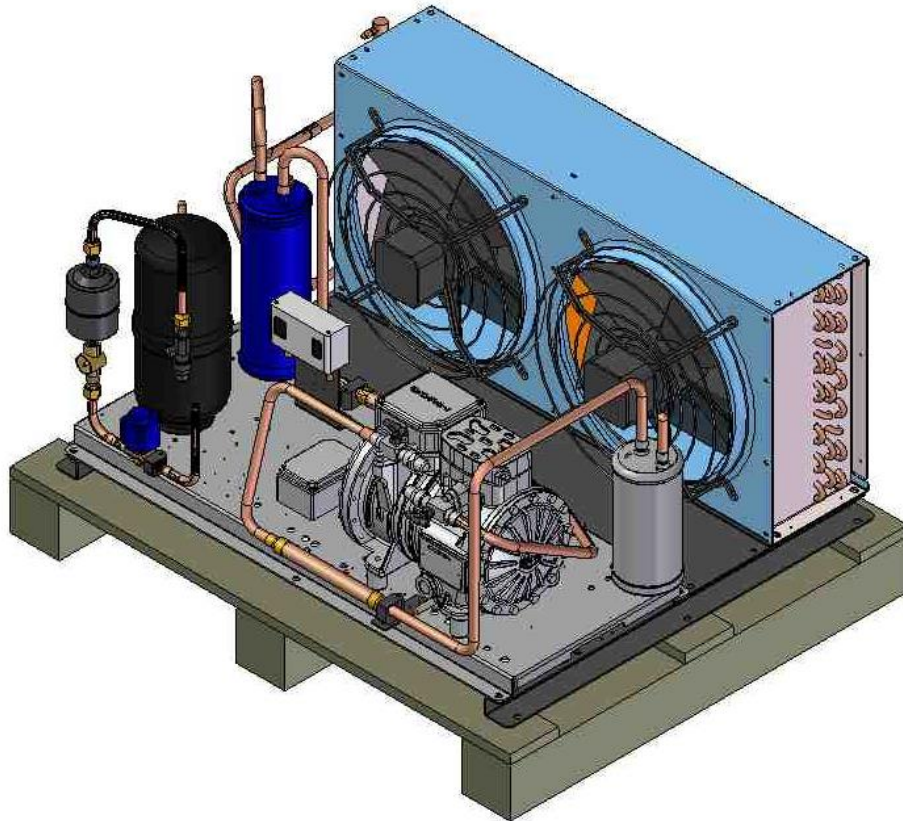

IMPORTANT INFORMATION-

REFER TO THE SECTIONS ON “WARNINGS AND SAFEGUARDS”, AND “INSTALLATION INSTRUCTIONS” BEFORE ATTEMPTING TO COMMISSION THIS CONDENSING UNIT.

CONTENTS



Page

1. Warnings and Safeguards	3
1.1 General Notes.....	3
1.2 Electrical Connection.....	3
1.3 Caution Auto Start and Reset.....	3
1.4 Control Wiring for Dorin Condensing Units.....	3
1.5 Personal Protective Equipment.....	3
1.6 Evacuation of Refrigerant.....	4
1.7 No Smoking	4
1.8 Caution – Unit Pressurized	4
1.9 Caution – Refrigerant Type	4
1.10 Caution – Lubricant Oil Type	4
1.11 Caution – Sharp Edges	4
1.12 Warning – Qualified Personnel	4
1.13 Caution – High and Low Temperatures	4
1.14 Caution – Deep Vacuum	5
1.15 Caution – Compressor Motor Protection	5
1.16 PURPOSE	5
1.17 Standard Design Conditions	5
2. Installation & Commissioning Instructions	6
2.1 General Instructions	6
2.2 REFRIGERATION PIPING.....	10
2.3 COMPRESSOR STARTING.....	10
2.4 FAN SPEED CONTROL	10
2.5 GENERAL COMMISSIONING AND DE-COMMISSIONING GUIDE	11
2.7 Important Notes	12
3. Dimensional Drawing	13
4. Wiring Diagram & Schematic	14
4.1 Schematic for Dorin Single Phase Condensing Units	14
4.2 Schematic for Dorin Single Phase Condensing Units with options	15
4.3 Schematic for Dorin Three Phase Condensing Units up to H380CC	16
4.4 Schematic for Dorin Three Phase Condensing Units up to H380CC with options	17
4.5 Schematic for Dorin Three Phase Condensing Units H405CC	18
4.6 Schematic for Dorin Three Phase Condensing Units H405CC with options	19



1. Warnings and Safeguards

Kirby is very conscious of safety issues when designing and manufacturing our products, but it is essential that the end user, installer or service personnel also exercises care when working with the units.

 Warning	<p>This indicates contents for which, if disregarded, the possibility of human death or severe injury can be assumed.</p>
 Caution	<p>This indicates contents for which, if disregarded, the possibility of human injury or the possibility of material damage can be assumed.</p>

1.1 General Notes

Kirby Condensing units fall under the requirements for commercial electrical equipment as per Standards Australia guidelines. Installation and major service of this unit must be carried out by a licensed contractor and in accordance with local regulatory guidelines.

Kirby Dorin Air Cooled Condensing Units have been designed for use in an indoor environment and must be adequately protected against adverse weather conditions if installed outdoors. Kirby makes no claim as to the protection rating for compressors or fans other than that stated by the manufacturer, nor any for the protection rating of the electrical box.

1.2 Electrical Connection



All electrical connections must be carried out by a licensed electrical contractor and in accordance with the relevant regulations.

Under no circumstances should access to the electrical box or components be attempted without first disconnecting the power supply to the unit.

Mains supply cabling must be in accordance with the [latest edition of AS/NZS 3000](#).



1.3 **Caution Auto Start and Reset**

Condensing unit and/or components may start automatically without any warning. The unit is fitted with a fan speed controller as standard, fan(s) will rev up and down, even turn on and off in response to variations in condensing pressure. Please see "Installation Instructions" for further details.

Condenser fans and compressors are thermally protected. When tripped, these components will not operate. Once sufficiently cooled however, the component [may automatically reset and operate without warning](#).

The unit is equipped with a High/Low pressure switch as standard. The switch is either a universal selectable auto or manual reset or fixed auto/auto-reset type on both high and low sides. If universal switch used then it is set to auto/auto at the factory. Please check the unit regarding the appropriate pressure switch.

WARNING: Do not insert any object into operating fans. Ignoring this warning may result in personal injury and/or severe equipment damage.

1.4 Control Wiring for Dorin Condensing Units

Control circuit is 240 volts. For wiring schematics refer to Section 4.

Wiring of Dorin three phase compressors to H380CC uses THERMIK overload protection, and is supplied as [standard](#). Please refer to the specific diagram supplied with the unit.

Fan overloads on all models up to H380CC are internal line break type.

[Wiring of Dorin three phase compressors from H405CC and above uses INT69 overload protection, and is supplied as standard. Fan overloads on these models are wired into the compressor control circuit.](#)

1.5 Personal Protective Equipment

It is recommended the following PPE is to be worn when carrying out any type of work, maintenance, installation or decommissioning



- Compressor and the pressure line piping may reach temperatures that may cause burning if touched.
- In case of leak of refrigerant avoid eye and skin contact.
- If the refrigerant needs to be removed from the system, do not disperse it in the environment; use specific equipment to collect the refrigerant.

1.6 Evacuation of Refrigerant

If the refrigerant needs to be removed from the system, it must not be released into the atmosphere. Federal regulations require the use of suitable recovery equipment to reclaim the refrigerant for re-use, or for recovery and destruction at an authorised destruction facility. It is illegal to intentionally vent refrigerant gas to atmosphere, and only licensed persons may remove refrigerant from the system.



1.7 No Smoking

Kirby recommends No Smoking within a distance of 15 metres of the unit.



1.8 Caution – Unit Pressurized

All units are pressurised with dry air or Nitrogen gas. Care must be taken to discharge the pressurized gas prior to installing or commissioning the equipment.



1.9 Caution – Refrigerant Type

All units are designed to work effectively with fluorocarbon refrigerants including R404A/R407F/R448A/R449A and R134a/R450A/R513A. Under no circumstances can a refrigerant such as R410A, Ammonia, Hydrocarbon, Water or Glycol be used in this product.

Refrigerant can be harmful if it is inhaled and/or makes contact with exposed skin. Refrigerant must be used and recovered responsibly, only by a licensed tradesperson. Extreme care must be taken when handling refrigerant, as personnel injury or death may occur.



1.10 Caution – Lubricant Oil Type

All compressors are charged with PolyolEster (POE) oil. POE can be used with HFC refrigerants, and HFC/HFO blends, such as described above. Use ONLY POE oil, do NOT mix POE with other oils, when using HFC refrigerants.



1.11 Caution – Sharp Edges

All units are manufactured with sheet metal and in this process all care is taken to ensure the edges are concealed. Avoid contact with sheet-metal edges and the coil fins. They can be sharp and are a potential personal injury hazard. Please take care when accessing in or around the unit.



1.12 Warning – Qualified Personnel

All units may only be installed, commissioned, decommissioned and serviced by qualified and trained personnel (refrigeration mechanics and/or electricians) who have sufficient knowledge in this type of equipment. It is the purchaser's responsibility to co-ordinate with qualified personnel as required.



1.13 Caution – High and Low Temperatures

Compressor housing and discharge line temperatures may reach 150°C due to failure of system components. Wiring and other materials which could be damaged by these temperatures should not come into contact with the housing or discharge line.

Moreover, even in normal working operation, the unit can generate very high (may exceed 100°C) and very low (below -40°C) temperatures on compressor housing and tubing surfaces resulting in the possibilities of severe contact burns. Special caution must be taken when working around the unit.



1.14 Caution – Deep Vacuum

Do NOT operate compressors in deep vacuum conditions as this can cause electrical failure. Compressors should never be used to evacuate refrigeration or air conditioning systems.



1.15 Caution – Compressor Motor Protection

Dorin 3-phase compressors from H33 and above are fitted with Thermistor motor protection and electronic control circuit break modules. Always check the thermistor module switch position if a compressor does not restart as expected.

NEVER apply 240V across thermistor terminals. Maximum test Voltage = 3V.
The thermistor control module is a “Fail-Safe” design. The control contact opens when power to the module is cut, and closes when power is returned only if the thermistors signal correct operating conditions. The thermistors should never be disconnected from the module, and the module should never be bypassed, when the unit is in operation.

Dorin H1 and H2 compressors are fitted with Thermik (internal control circuit break) motor protection. Please refer to your specific unit for the exact specification.

In addition to the above, thermal over-current protection is fitted to the compressor contactor, and phase failure module protection is available, as an optional extra. Please refer to your Kirby sales representative for details.

1.16 PURPOSE

Kirby Dorin Commercial Air Cooled condensing units are standard OEM products including “high”, “medium”, and “low” temperature application ranges. They are designed for continuously supplying and receiving the refrigerant to and from the evaporator(s), and rejecting the heat extracted from the cold space to the surrounding atmosphere where the units are installed.

Kirby Dorin Commercial condensing units are intended for installation in a typical indoor or weather protected outdoor environment (Refer to the General Arrangement Drawing section for details) with the condensing temperature no greater than 58°C and compressor return vapour temperature no greater than 20°C.

They are not intended for environments that may have harmful, corrosive or flammable atmospheres. Marine environments are considered corrosive; please consult Heatcraft before installing in this environment.

1.17 Standard Design Conditions

MAXIMUM ALLOWABLE PRESSURES (PS, PSS)

Maximum allowable pressure (PS, PSS) is based on the design pressure or maximum allowable pressure of the lowest rated component in the system.

MAXIMUM AMBIENT

Maximum ambient condition is based on calculated maximum condensing pressure for various permitted refrigerants. Calculations have been verified by testing sample units of each unit range.

AS/NZS5149.2 INFORMATION.	MAX AMB	UNIT DATA		
		PS	PSS	Refrigerant
ALL CC AND CC/HTCR COMPRESSORS	43	3050	2000	A1: R404A/R407F/R448A/R449A/R134a/R513A/R450A
VSD MODELS- CC COMPS	REFER TABLES	3050	2000	A1: R404A/R407F/R448A/R449A/R134a/R513A/R450A

REFER TO YOUR KIRBY REPRESENTATIVE FOR INFORMATION ON CC COMPRESSOR MODELS ON R450A/R513A

LMH APPLICATION (“CC” compressors)

LMH range condensing units are typically designed, for primary refrigerant R404A, to be used in commercial cool room applications ranging from -40°C to +10°C. Product pull-down requirements may be accommodated by this range.

Maximum ambient condition is 43°C . If conditions exceed the maximum temperatures for any significant length of time, system shut-down may occur.

For R407F/R448A/R449A and R134a/R450A/R513A usage, please refer to other sections of this booklet for control setting information etc.

For R407F/R448A/R449A refrigerant operation below -20°C sst, please refer to other sections of this booklet for important information.

Please refer to the specific sales data sheet for standard Dorin condensing unit configurations, options offered and other detailed information such as capacity variations for other refrigerants.

For special design requirements (non standard conditions and/or refrigerants), please inquire with your local representatives and/or Kirby local branches, go on-line with smart@access, or call our national telephone number 13 23 50 for your nearest available information resources.

2. Installation & Commissioning Instructions

2.1 General Instructions

This product must be installed and maintained in accordance with the following:

- AS/NZS5149:2016 – Parts 3 & 4 (as applicable)
- AS4041:1998 – Pressure Piping
- Refrigerant Handling Code of Practice, Part 2

Useful information -

- Ozone Protection and Synthetic Greenhouse Gas Management Act 1989 (and amendments) and Regulations 1995
- AIRAH, DA19 – HVAC&R Maintenance
- CIBSE Code M - Commissioning Management

NOTE- There may be other applicable Codes and Standards that must be considered. It is the responsibility of the Installer and Owner to ensure all requirements are considered and complied with.

2.1.1 Lifting of unit



The unit **may have** one end heavier than the other, caution must be taken when loading / unloading. The compressor is the heaviest part of the unit. Units with compressors placed off centre should have forks placed toward the compressor end when lifting.

Slings may be placed under the base but care must be taken to adjust the lengths appropriately to account for the weight distribution.

Always take care to ensure a proper weight balance before lifting and moving unit.

2.1.2 Unpacking of Unit

When unpacking, check for any damage to packing material or the unit itself, which may affect the unit's performance. **If any such damage is evident, please contact your Kirby branch.**

2.1.3 Location and securing of Unit

If the unit is to be located in close proximity to a wall, or in a confined passageway, please refer to dimensional drawing for minimum distances to walls, etc, to ensure proper airflow and access to unit. Unit must be securely fastened to a hard and level surface to prevent it from falling/ tipping over.

It is particularly important to allow sufficient unobstructed space around the unit to prevent warm air recirculation to the condenser.

The liquid sight glass is located on the side of the compressor facing the front of the unit (viewed from the compressor side). Sufficient room should be allowed to the front to view the sight glass in operation.



2.1.4 System Holding Charge **Caution: Unit is Pre-Pressurised**

The system as supplied is pressurised at the factory with a mixture of R134a and Nitrogen gas. **If the system is not pressurised on delivery, please contact your Kirby branch.**

Remove the gas charge in an appropriate manner. Care must be taken to release the pressure before attempting to gain access to any part of the refrigeration system.

The unit should be evacuated to a pressure of **200 microns or less** prior to commissioning.

2.1.5 Pressure Settings

PRESSURE RELIEF VALVES (Where required)

High Side- Pressure relief valves must be selected based on the system PS. The maximum allowable pressure of the pressure vessel may not determine the PRV setting if it is not the lowest rated system component. Please note the condensing unit may NOT be the lowest rated component in the system.

Low Side (where applicable)- Pressure relief valves must be selected based on system PSS. Please note that the low side of the condensing unit may NOT be lowest rated component in the system.

HP CONTROL SETTING

Compressor HP (where fitted)- Setpoint must be equal to or less than 90% of the compressor PS.

Unit HP- Setpoint must be equal to or less than 90% of the PRV setting (where fitted), or less than or equal to Unit PS if no PRV fitted.

Please note this setting may not be adequate to protect other parts of the system with a lower PS rating. If required the Unit HP may be set to less than or equal to the system PS.

Note when setting the HP control- Consideration must also be given to the type of refrigerant used and the maximum ambient temperature to ensure compliance with AS/NZS5149.2 and avoiding nuisance tripping.

Kirby also recommends the LP switch to be used **only** as a safety protection device. Depending on the application and compressor, LP cut-in and differential points should be set with the following considerations:

- Set the cut-out points at 3–5 K below the respective minimum design saturated suction temperatures (Refer to the Standard Design Conditions section for saturated suction temperature ranges).
- Set the differential to no more than 2 Bar.
- The cut-out pressure shall be in the positive pressure region.
- When the unit is installed in a cold ambient, the cut-out pressure shall be lower than the pressure corresponding to the ambient temperature.



2.1.6 Auto Reset & Motor Protection

The optional phase failure control is a solid state motor protector for 3 phase motors with adjustable start delay, anti short cycle timer and fault memory. Refer SP308-1 for details.

Fans and compressors are thermally protected. When tripped, these components will not operate. Once sufficiently cooled however, the component will automatically reset and may operate without warning.

Single phase fans up to 450mm are equipped with an internal line break thermal overload.

500mm 1 phase fans are equipped with a thermocontact. The Thermocontacts are wired in series to the compressor contactor coil. When tripped, the compressor and fans will switch off. Once cooled, the overload will reset, and if the fault has not cleared, the unit will cycle on the fan overload. Eventually the HP switch may switch off the unit.

Three phase compressors up to H380CC have an NC-protection switch (Thermik). Three phase compressors from H405CC and above have an INT69 thermistor module, which is supplied factory wired. Always check the thermistor module switch position if a compressor does not restart as expected. **Thermocontacts and Thermistor modules must be connected to the control circuit, otherwise warranty may be void.**

The N/O contact 97-98 on the thermal overload is optionally connected to the phase failure module start delay trigger. The fault signal will cause a 15 minutes start delay.

Never apply 240V across thermistor terminals. Maximum test Voltage=3V

The thermistor control module is a “Fail-Safe” design. The control contact opens when power to the module is cut, and closes when power is returned **only** if the thermistors signal correct operating conditions. **The thermistors should never be disconnected from the module, and the module should never be bypassed, when the unit is in operation.**

The unit is equipped with a High/Low pressure switch as standard. The standard switch may be a “universal” reset or “auto/auto” type. Factory setting is for auto reset on both high and low sides.

The optional phase failure module start delay function has been utilised as follows-

The tripped signal is connected to the memory trigger connection. This signal will cause a 15 minutes start delay with memory function and light. The LP should not be used for pump down.

A contactor and thermal over-current protection is fitted to the compressor, compressor contactor K1 Thermal Overload N/O 97-98 to the start delay trigger (without memory or light).

Compressor restart will be delayed by 15 minutes when activated by these 2 fault conditions. Reset the Safety circuit MCB to avoid the 15 min delay on the module.

2.1.7 High Compressor Temperature

Compressor housing and discharge line temperatures may reach 150°C due to failure of system components. Wiring and other materials which could be damaged by these temperatures should not come into contact with the housing or discharge line.

2.1.8 Deep Vacuum

Do not operate compressors in deep vacuum conditions as this can cause electrical failure. Compressors should never be used to evacuate refrigeration or air conditioning systems.

2.1.9 Lubrication

Dorin H semi-hermetic compressors use polyolester oil* as lubricant. The oil charge must be checked before commissioning. Check the oil level again after a minimum of 2 hours operation at nominal conditions. Normally the quantity of oil added should be no more than 2% of the total refrigerant charge.

(*ICI Emkarate RL 32 for H1 to H33, or original manufacturers supply- refer nameplate)

NOTES ON POLYOLESTER OILS

Use only POE oils with HFC and [HFC/HFO blend](#) refrigerants. Do not mix POE with other oils when using [these refrigerants](#). Small quantities of other oil types may be mixed with POE oil when using HCFC refrigerants (eg R22).

2.1.10 Routine Maintenance of Unit

Condenser;

Condenser should be cleaned at 3 monthly intervals.

System operation;

System operation should be checked every 6 months. Checks should include gas charge and electrical connections.

Compressor and the pressure line piping may reach temperatures that may cause burning if touched!

2.1.11 Discharge Temperature Control (DTC)- [R407F](#) Low Temp Applications

A DTC device can be installed on [H405CC models \(and larger\)](#). In order to minimize the liquid quantity injected by the DTC device, and consequently to improve the efficiency of the system, it is necessary to pay attention in limiting the suction gas superheating and in designing the condenser and the evaporator ([work with the minimum allowable temperature rise](#)). Refer to your Kirby representative for more details.

2.1.12 Crankcase Heater

[Air cooled condensing units with](#) Dorin compressors are factory wired with a 60W–220V (<H280CC) or a 100W–220V (>H280CC) crankcase heater. A crankcase heater protects against off-cycle migration of refrigerant by maintaining the crankcase at a higher temperature. It will not offer protection against continuous liquid floodback. The effectiveness of a crankcase heater can be checked by measuring the oil temperature, which should be at least 10K above ambient temperature. The ideal oil temperature should be between **50°C to 70°C**. Checks must be made to ensure that the appropriate oil temperature is maintained at all ambient conditions.

2.1.13 Wiring of Units

Please refer to electrical diagrams for suggested wiring of Dorin units in Section 4. The diagrams include fully optioned units wired by the factory. Other wiring requirements and the overall system wiring is the responsibility of the installer.

2.1.14- Capacity Control

Dorin H33 compressors are 4 cylinders with 2 discharge heads. When capacity control is in operation, one discharge head is disabled by blocking the suction gas from entering the cylinders. Due to less refrigerant flow, thus less cooling effect to the electric motor, the running discharge head becomes hotter and the inactive head continually expands & recompresses the gas that remained in the discharge head, thus heating it up over time. Hence it is recommended to have the following protection features implemented during capacity control operation.

- Fit a head cooling fan to reduce the temperature of compressor heads. Refer to the section of “General wiring schematic with options (Dorin)” for the “Head Cooling Fan” kit.
- Limit compressor operating range.
- Limit compressor continuous operating time to 2 – 3 hours. Then a 3 – 5 minutes operation at full capacity is necessary to cool the compressor down before the next capacity control operation.

OPERATING ENVELOPES

OPERATING ENVELOPES FOR DORIN COMPRESSORS
 R404A- H11/H2/H32-HTCR

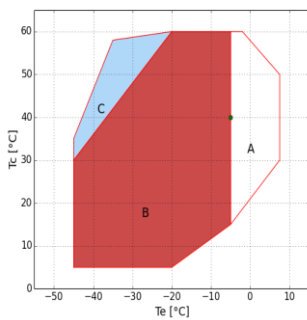

R407F- H11/2/32-HTCR

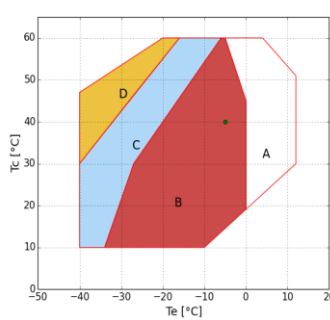

R448A H11, H2, (HTCR MOTORS), H33

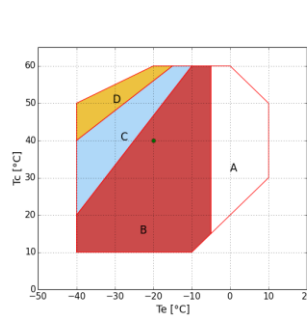

R134a- H11/2/32-HTCR
 R450A, R513A

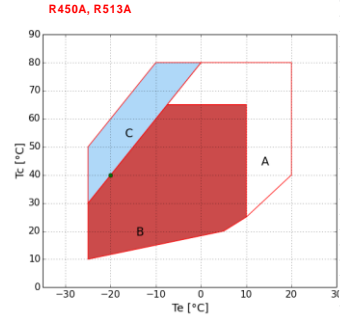

R404A- H33

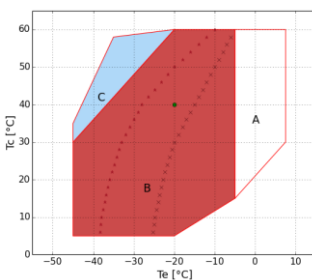

R407F- H33

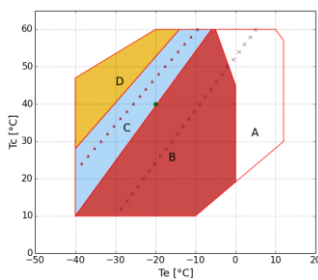

R448A/R449A- H33

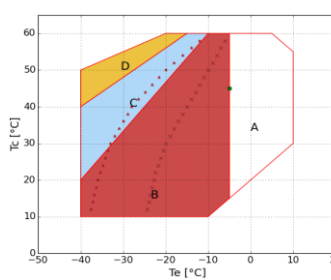

R134a- H33
 R450A, R513A

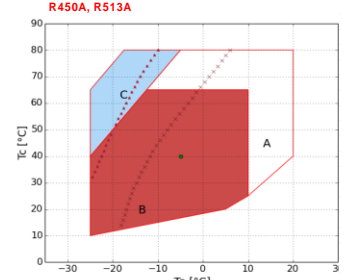

A = "CC" models only
 B = Standard application
 C = Head cooling fan or max superheating 20K
 x = Min Te 50%
 * = Min Te 50% Head cooling fan or max superheating 20K
 • = Dew temperature

A = "CC" models only
 B = Standard application
 C = Head cooling fan or max superheating 20K
 D = Head cooling fan + max superheating 20K
 x = Min Te 50%
 * = Min Te 50% Head cooling fan or max superheating 20K
 • = Dew temperature

A = "CC" models only
 B = Standard application
 C = Head cooling fan or max superheating 20K
 D = Head cooling fan + max superheating 20K
 x = Min Te 50%
 * = Min Te 50% Head cooling fan or max superheating 20K
 • = Dew temperature

A = "CC" models only
 B = Standard application
 C = Head cooling fan or max superheating 20K
 x = Min Te 50%
 * = Min Te 50% Head cooling fan or max superheating 20K
 • = Dew temperature

2.2 REFRIGERATION PIPING

Refrigeration piping work shall be carried out professionally by qualified refrigeration mechanics in accordance with applicable national and local regulations and in conformance with good engineering practices required for the proper operation of the refrigeration system.

All condensing units are supplied clean and internally charged with dry air or nitrogen to prevent oxidation and ingress of moisture or foreign matter. Care shall be taken during installation of the piping to prevent entrance of foreign matter or moisture by minimising the time that the piping is uncapped.

The interconnecting refrigeration pipe size is not necessarily the same size as the outlet on the unit. The pipe sizes shall be selected/calculated based on the best compromise of minimizing refrigerant pressure drop and refrigerant velocity to ensure efficient oil return. [A selection program is available ON-LINE](#) to assist in the calculation of pipe sizes.

Horizontal suction lines shall slope towards to the units to allow the oil to return freely to the compressor by gravity. A 1:100 slope is considered sufficient. The use of oil trap and double risers may be necessary on vertical sections. Suction line piping shall be insulated to minimise the superheat effect to the vapour.

If in doubt during the installation, please consult with your local sales representatives and/or application engineers from [Kirby](#) for technical support.

2.3 COMPRESSOR STARTING

2.3.1 DOL START (H80-H405)

Refer to Section 4 for wiring and schematic diagrams.

[Dorin H11 \(H80 to H281\), H2 \(H300 to H380\), and H33 \(H405\) compressors are three phase compressors with 380-420V 3Ph 50Hz STAR connected motors for Direct-On-Line starting.](#)



The terminal links on 3 phase motors must be connected in the star configuration as shown in the wiring diagram (Section 4 of this document, on the unit schematic diagram, or inside the compressor j-box lid).

For applications where power supply conditions are suspect with regard to voltage and/or current capacity limitations, please refer to your [Kirby](#) Application Engineer for details of possible starting solutions.

2.4 FAN SPEED CONTROL

A fan speed controller is fitted as standard to all Commander condensing units. It is an encapsulated controller- "XGE-4CC30" from SAGINOMIYA SEISAKUSHO

- This controller varies the supply voltage to the condenser fan motor from 30% to at least 95% over the proportional condensing pressure band which is factory fixed at 6 Bar.
- The set point is defined at 90% supply voltage to the fan motor, and is set at 19 Bar by the control manufacturer. By turning the setting screw clockwise, the pressure setting increases. Turn anti-clockwise to decrease the pressure setting. It is approximately 1.5 Bar per full (360°) turn.
- The cut-off point is defined at 30% supply voltage to the fan motor, and corresponds to 13 Bar depending on actual load and / or power supply.
- When the condensing pressure reduces to the cut-off condition, the controller will cut off the supply to the fan and the fan will stop. The fan restarts at low speed when the pressure rises. For details, please refer to Saginomiya product specification.
- Kirby factory set point for primary refrigerant R404A/R407F is 19 Bar(g) for M/T and 14 Bar(g) for L/T units. R448A/R449A some adjustment may be needed due to slightly higher condenser KTD's expected. Kirby recommends 10 Bar(g) for R134a/R513A/R450A units.



- **Warning – Setting for Other Refrigerants**

It is the installer's responsibility to set the control correctly for use with refrigerants other than R404A.

2.5 GENERAL COMMISSIONING AND DE-COMMISSIONING GUIDE

2.5.1 Warning – Commissioning

Refrigeration system commissioning shall be carried out professionally by qualified refrigeration mechanics in conformance with good engineering practices required for the proper operation of the refrigeration system.

After all installation and electrical work is completed, the entire refrigeration system must be leak tested. After satisfactory testing of the refrigeration system, then refrigeration lines shall be insulated as necessary. The insulation located in outdoor environments shall be protected from UV exposure.

Before charging the refrigerant, the entire refrigeration system shall be evacuated by connecting a good, high vacuum pump to both the high-pressure side and low-pressure side service valves or ports.

It is important to apply good engineering practice when charging any refrigerant, but in particular blended refrigerant, such as R404A/R407F/R448A/R449A/R450A, require proper procedures to be observed:

- Initially charge 60 to 80% of the expected refrigerant charge in liquid form into the liquid receiver with the compressor not running (after evacuation to the correct pressure).
- When the system pressure has stabilized, start the compressor & slowly charge the remaining refrigerant quantity into the suction line in liquid form through a gauge manifold or a throttling valve to allow it to vaporize before entering the compressor. If the system is fitted with an accumulator, it is preferable to charge upstream of the accumulator.
- After initial running of the system, check the refrigerant charge condition at the sightglass and add any required refrigerant in the suction side as noted above, or remove excess refrigerant into an approved reclaim cylinder.

• Kirby is dedicated to providing safe products and protecting the environment by complying with all applicable national laws and regulations governing environmental protection. New and used refrigerants cannot be vented into atmosphere. Reclaim all used refrigerants. Ensure your refrigerant handling procedure complies with the relevant regulations.

Double check all field wiring connections and factory terminations. Factory connections can vibrate loose during shipment. Ensure correct fan motor rotation, airflow is induced from coil side and forced out of fan motor side.

Ensure that the compressor crankcase heater has been energised for a minimum 12 hours before initial start-up and / or after prolonged shutdown periods.

After the successful start up of the system, generally check:

- Current draw and voltage levels.
- Suction superheat settings and discharge temperatures.
- Abnormal refrigeration piping vibrations.
- Oil level and refrigerant charge.



2.5.2 **Warning – Decommissioning**

In order to remove the unit from its mounting place, the following procedures need to be carried out professionally by qualified personnel. Failure to do so may result in personal injury or death, property damage by fire or explosion. Discharge of refrigerant to atmosphere is illegal and may result in heavy fines by relevant regulatory authorities.

- Pump down the entire refrigerant charge into the liquid receiver or appropriate container such as reclaim cylinder, and shut related valves. **All reclaimed refrigerant that is not re-used must be taken to an approved refrigerant recycling or destruction facility.** Kirby Branches will accept the used refrigerant.
- Disconnect the power supply. Remove all necessary field electrical wiring and related components, leaving the earth wire to the last.
- Care must be taken when disconnecting the refrigeration piping because of unbalanced pressure between the unit and ambient. There may be a small amount of refrigerant trapped in the oil, the pressure rise in the system will boil and vaporise the refrigerant resulting in a potential personal injury hazard.
- Cut and solder seal the refrigeration liquid line and suction line pipe connections.
- Remove the unit from its mounting place. Adequate equipment must be provided as per lifting notes.

2.6 **Material Safety Data Sheets – M.S.D.S.**

These are available from your nearest Kirby Branch for all refrigerants that Commander condensing units are approved for, and for oils and other materials as needed.

2.7 **Important Notes**

To ensure Commander condensing units operate efficiently and for a long working life, always obtain genuine replacement parts from your local Kirby Wholesale Branch. Genuine replacement parts are covered by the warranty. Refer to the Standard Terms & Conditions of Sale in the Price Guide for warranty statements.

Continuous product improvement is our company policy. Kirby reserves the right to make changes in product specifications and/or this instruction manual without notice.

Kirby HVAC&R is dedicated to providing safe products and protecting the environment by complying with all applicable national laws and regulations governing environmental protection. New and used refrigerants cannot be vented into atmosphere. Reclaim all used refrigerants. EPA regulations are constantly updated. Ensure your refrigerant handling procedure complies with the relevant regulations.

3.

Dimensional Drawing

Drawing is representative only. Please refer to the actual unit for correct layout etc.

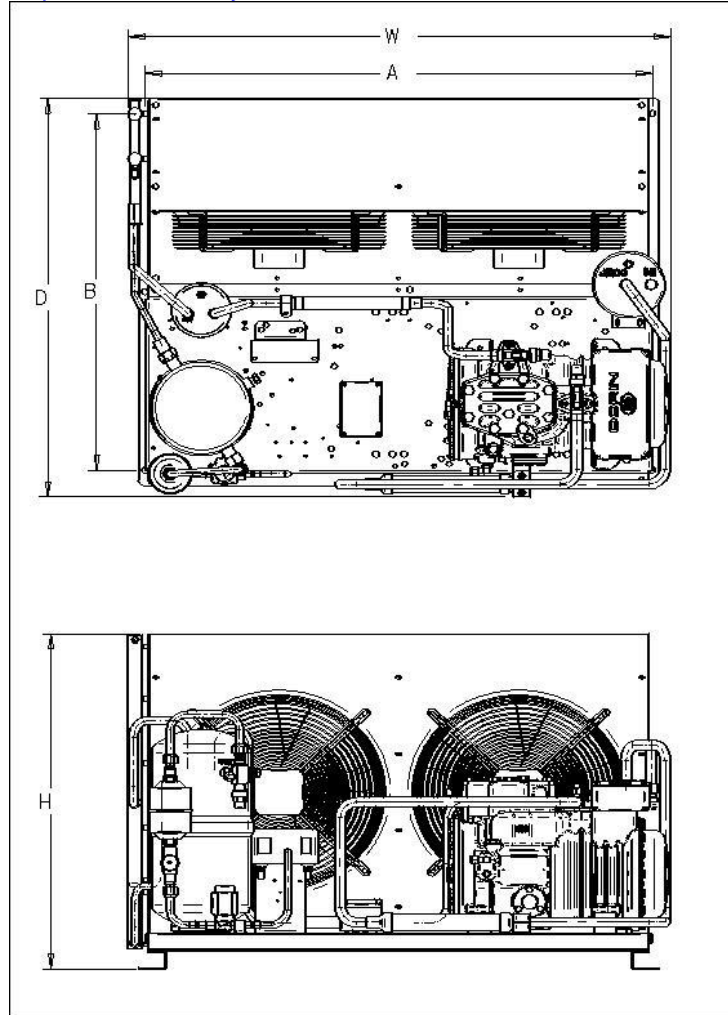

min. wall distance: 500 mm

UNIT	O/ALL DIM'NS mm				
MODEL	HEIGHT	WIDTH	DEPTH	MTG CTRS	
	H*	W	D	A	B
PCS022LMHA1-4	451	903	602	820	510
PCS031LMHA1-4	496	947	784	915	700
PCS039LMHA1-4	496	947	784	915	700
PCS044LMHA1-4	496	953	784	915	700
PCS057LMHA1-4	496	953	784	915	700
PCS071LMHA1-4	556	955	784	915	700
PCS084LMHA1-2	658	973	798	915	700
PCS101LMHA1-2	658	973	798	915	700
PCS126LMHA1-4	808	1262	921	1210	814

4. Wiring Diagram & Schematic

4.1 Schematic for Dorin Single Phase Condensing Units

 **Warning**  **Electrical 230 / 240 Volt REFERENCE ONLY- NOT AVAILABLE FROM 4/2015**

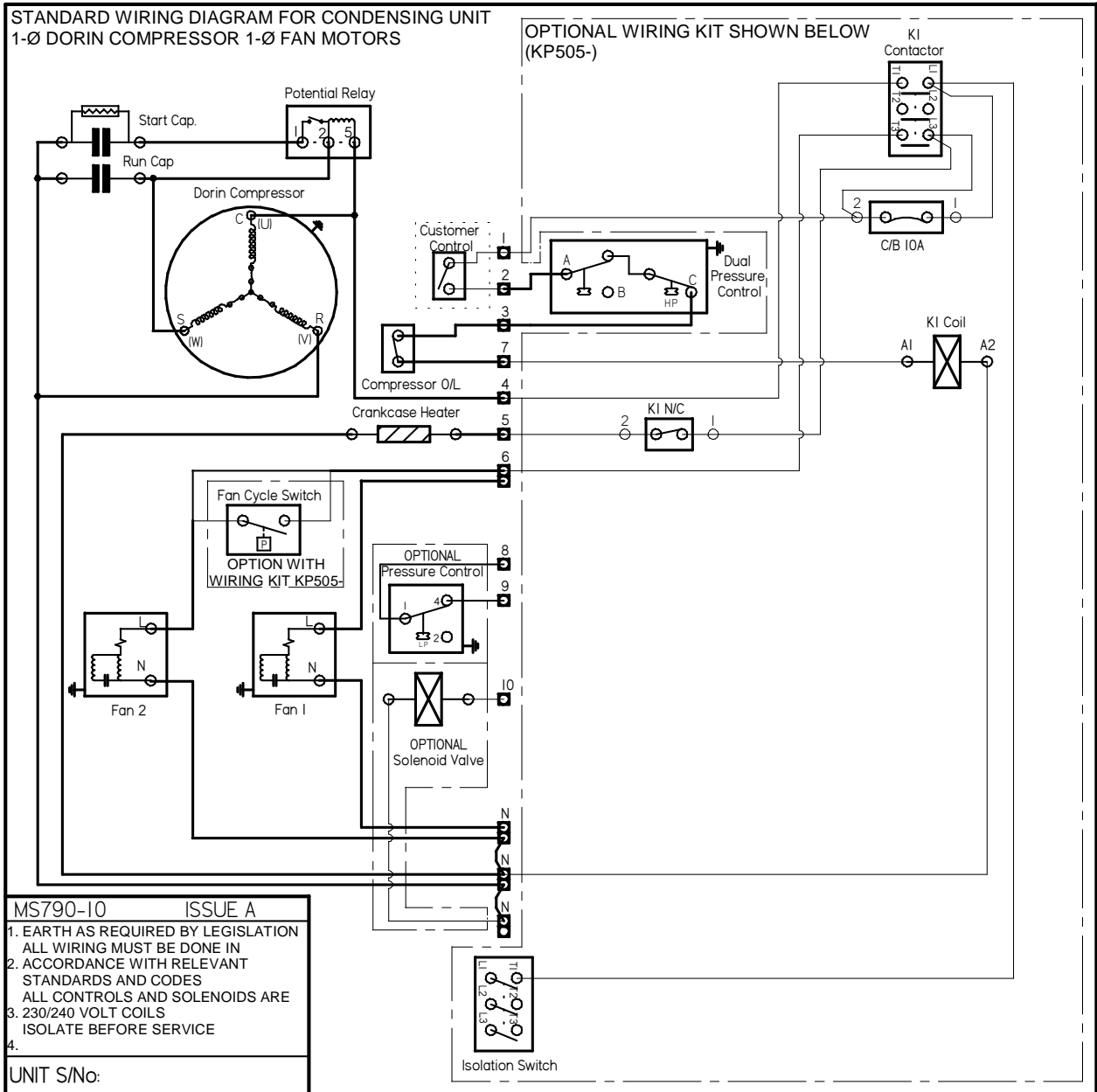

4.2 Schematic for Dorin Single Phase Condensing Units with options



Warning



Electrical 230 / 240 Volt

REFERENCE ONLY- NOT AVAILABLE FROM 4/2015

STANDARD WIRING DIAGRAM FOR CONDENSING UNIT
 1-Ø DORIN COMPRESSOR 1-Ø FAN MOTORS

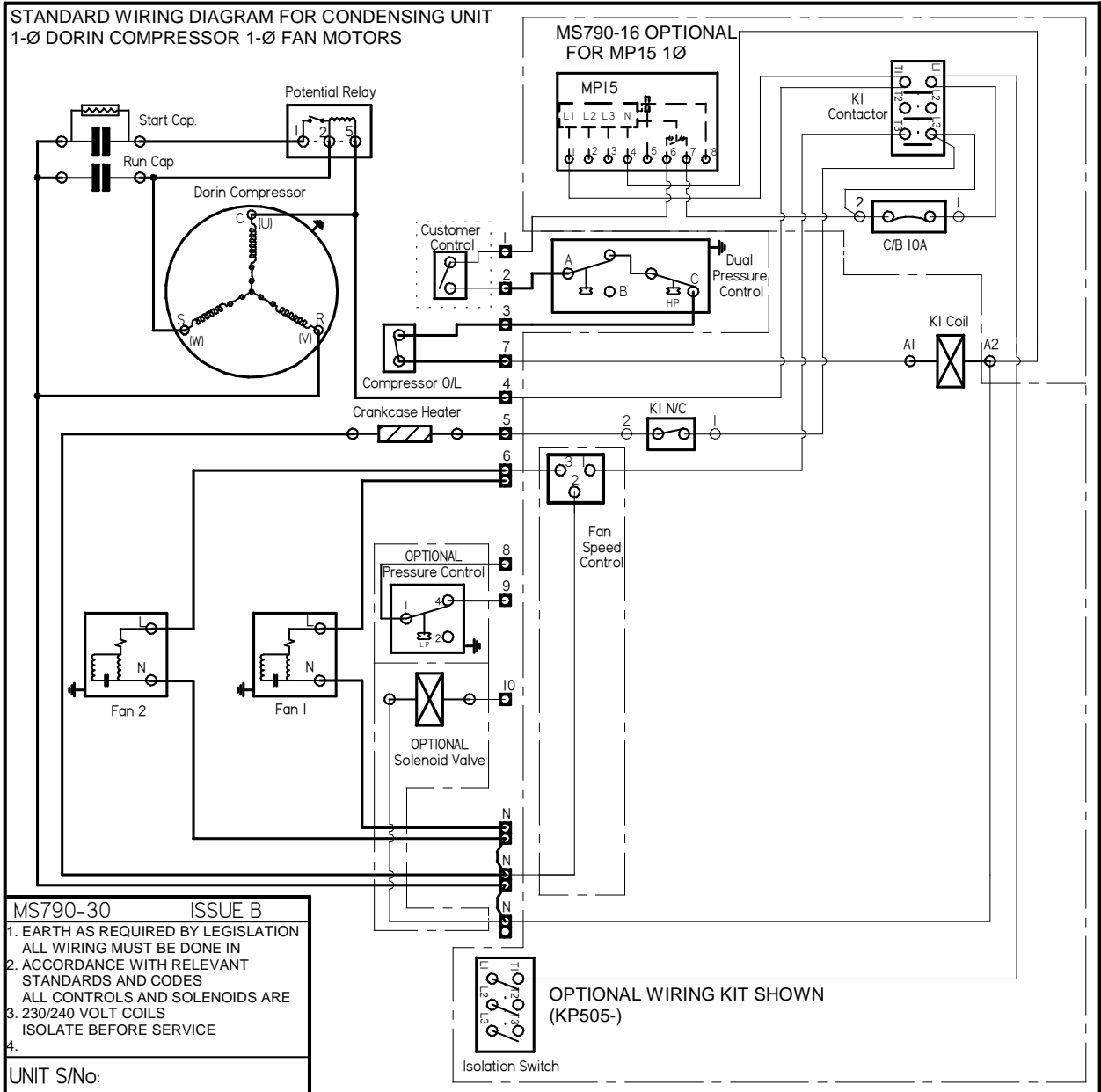

4.3 Schematic for Dorin Three Phase Condensing Units up to H380CC



Warning



Electrical 400 Volt ± 10% Volt (nominal 415V for Australia)

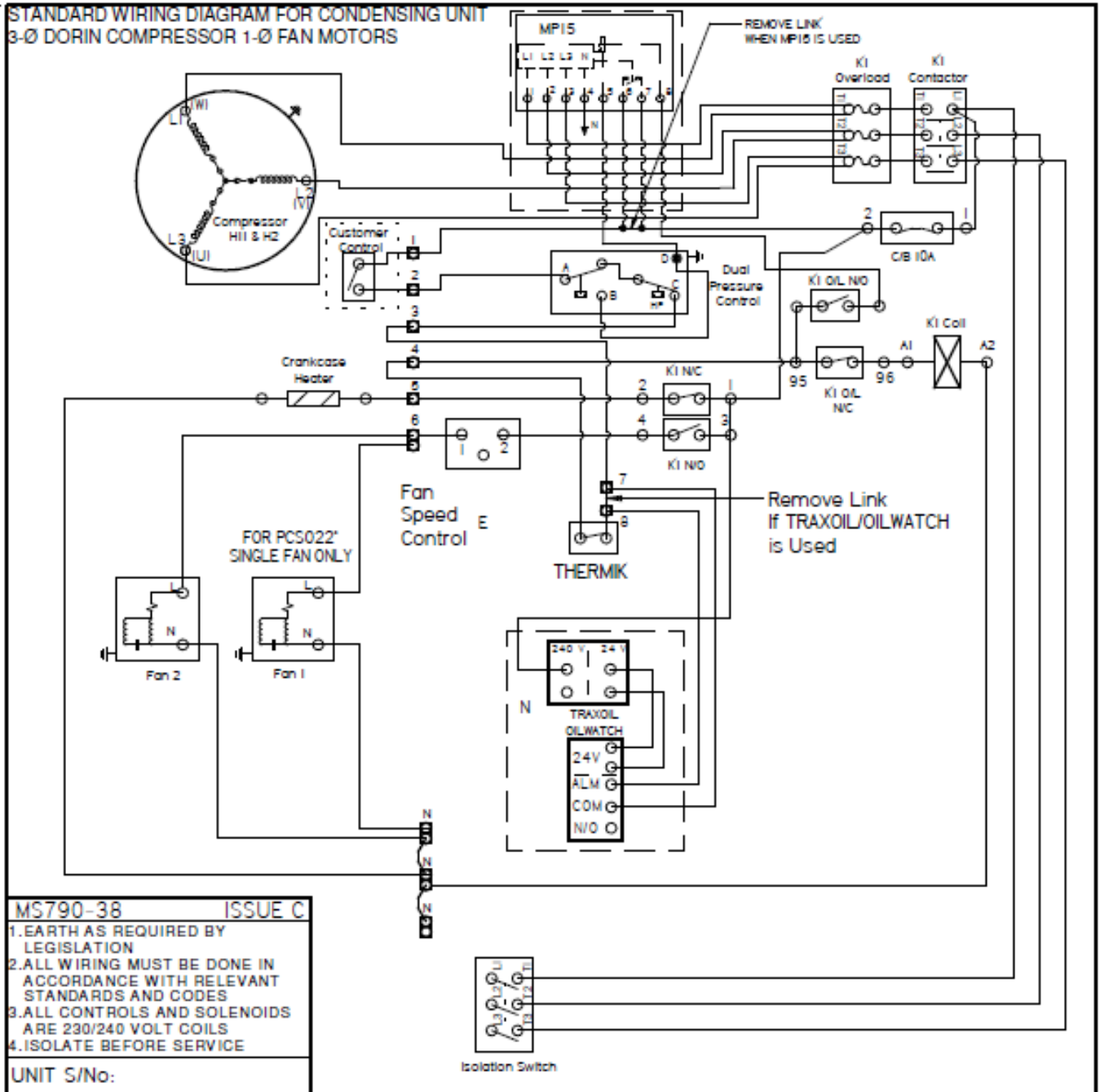

4.4 Schematic for Dorin Three Phase Condensing Units up to H380CC with options



Warning



Electrical 400 Volt \pm 10% Volt (nominal 415V for Australia)

REFER TO MS790-38 FOR ALL AVAILABLE OPTIONS

4.5 Schematic for Dorin Three Phase Condensing Unit- H405CC



Warning **Electrical 400 Volt ± 10% Volt (nominal 415V for Australia)**

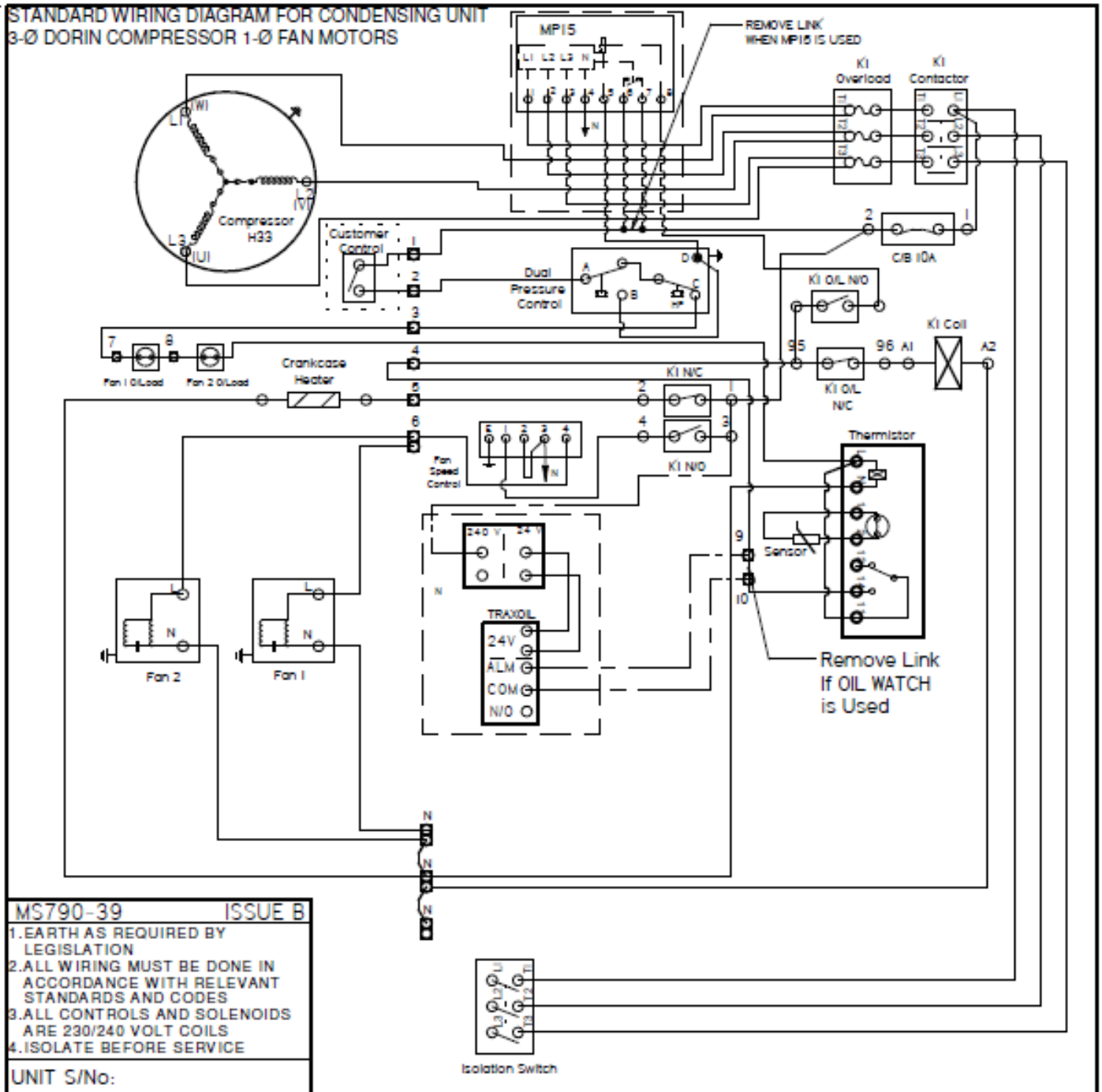

4.6 Schematic for Dorin Three Phase Condensing Unit- [H405CC](#) with options



Warning



Electrical 400 Volt \pm 10% Volt (nominal 415V for Australia)

[REFER TO MS790-39 FOR ALL AVAILABLE OPTIONS](#)

COMMISSIONING NOTES

UNIT SERIAL NUMBER

INSTALLATION/COMMISSIONING DATE(S)