



Owner's Manual

Original Instructions

Commercial Air Conditioners

Ducted Type Split Air-Conditioning Units(Inverter Series)

Models:

FGR20Pd/DNa-X(Au)

FGR24Pd/DNa-X(Au)

Thank you for choosing commercial air conditioners. Please read this Owner's Manual carefully before operation and retain it for future reference.

If you have lost the Owner's Manual, please contact the local agent or visit www.gree.com or send an email to global@gree.com.cn for the electronic version.

GREE ELECTRIC APPLIANCES, INC. OF ZHUHAI

To Users

Thank you for selecting Gree's product. Please read this instruction manual carefully before installing and using the product, so as to master and correctly use the product. In order to guide you to correctly install and use our product and achieve expected operating effect, we hereby instruct as below:

- (1) This appliance is not intended for use by persons (including children) with reduced physical, sensory or mental capabilities, or lack of experience and knowledge, unless they have been given supervision or instruction concerning use of the appliance by a person responsible for their safety. Children should be supervised to ensure that they do not play with the appliance.
- (2) In order to ensure reliability of product, the product may consume some power under stand-by status for maintaining normal communication of system and preheating refrigerant and lubricant. If the product is not to be used for long, cut off the power supply; please energize and preheat the unit in advance before reusing it.
- (3) Please properly select the model according to actual using environment, otherwise it may impact the using convenience.
- (4) This product has gone through strict inspection and operational test before leaving the factory. In order to avoid damage due to improper disassembly and inspection, which may impact the normal operation of unit, please do not disassemble the unit by yourself. You can contact with the special maintenance center of our company if necessary.
- (5) For personal injury or property loss and damage caused by improper operation such as improper installation and debugging, unnecessary maintenance, violation of related national laws and rules and industrial standard, and violation of this instruction manual, etc., we will bear no liability.
- (6) When the product is faulted and cannot be operated, please contact with our maintenance center as soon as possible by providing the following information.
 - 1) Contents of nameplate of product (model, cooling/heating capacity, product No., ex-factory date).
 - 2) Malfunction status (specify the situations before and after the error occurs).
- (7) All the illustrations and information in the instruction manual are only for reference. In order to make the product better, we will continuously conduct improvement and innovation. We have the right to make necessary revision to the product from time to time due to the reason of sales or production, and reserve the right to revise the contents without further notice.
- (8) The final right to interpret for this instruction manual belongs to Gree Electric Appliances Inc. of Zhuhai.
- (9) In relation to harmonics need distribution network operator to connect such equipment locally to the public low-voltage systems.
- (10) This appliance can be used by children aged from 8 years and above and persons with

reduced physical, sensory or mental capabilities or lack of experience and knowledge if they have been given supervision or instruction concerning use of the appliance in a safe way and understand the hazards involved. Children shall not play with the appliance. Cleaning and user maintenance shall not be made by children without supervision.

- (11) If the supply cord is damaged, it must be replaced by the manufacturer, its service agent or similarly qualified persons in order to avoid a hazard.

Exception Clauses

Manufacturer will bear no responsibilities when personal injury or property loss is caused by the following reasons:

- (1) Damage the product due to improper use or misuse of the product;
- (2) Alter, change, maintain or use the product with other equipment without abiding by the instruction manual of manufacturer;
- (3) After verification, the defect of product is directly caused by corrosive gas;
- (4) After verification, defects are due to improper operation during transportation of product;
- (5) Operate, repair, maintain the unit without abiding by instruction manual or related regulations;
- (6) After verification, the problem or dispute is caused by the quality specification or performance of parts and components that produced by other manufacturers;
- (7) The damage is caused by natural calamities, bad using environment or force majeure.

CONTENTS

1	Safety precautions.....	1
1.1	Safety Notices (Please be sure to abide)	1
1.2	Power supply demand.....	1
2	Installation of Indoor Unit.....	2
2.1	Selection proper installation location	2
2.2	Outline Dimension and Installation Spots	2
2.3	Drainage Pipe Installation and Drainage System Testing	4
2.4	Installation of Air Duct	5
2.5	Installation of Wired Controller	7
2.6	Wiring Work	7
3	Installation of Outdoor Unit	9
3.1	Dimension of Outdoor Unit and Mounting Hole	9
3.2	Installation space requirement.....	10
3.3	Refrigerant pipe connection	10
3.4	Vacuum Pumping, Refrigerant Adding.....	10
3.5	Electric Wiring	12
4	Check Items after Installation and Test Operation	14
4.1	Check Items after Installation	14
4.2	Test operation and Debugging.....	14
5	Common Malfunctions and Troubleshooting.....	21
6	Error Indication	23
7	Maintenance and Care	25
7.1	Outdoor Heat Exchanger.....	25
7.2	Drain Pipe	25
7.3	Notice before Seasonal Use.....	25
7.4	Maintenance after Seasonal Use	26
7.5	Parts Replacement.....	26
8	After-sales Service.....	26

1 Safety precautions

1.1 Safety Notices (Please be sure to abide)



Warning: If not abide strictly, it may cause severe damage to the unit or the people.



Note: If not abide strictly, it may cause slight or medium damage to the unit or the people.



This sign indicates that the operation must be prohibited. Improper operation may cause severe damage or death to people.



This sign indicates that the items must be observed. Improper operation may cause damage to people or property.



This marking indicates that this product should not be disposed with other household wastes throughout the EU. To prevent possible harm to the environment or human health from uncontrolled waste disposal, recycle it responsibly to promote the sustainable reuse of material resources. To return your used device, please use the return and collection systems or contact the retailer where the product was purchased. They can take this product for environmental safe recycling.



WARNING!

This product can't be installed at corrosive , inflammable or explosive environment or the place with special requirements, such as kitchen or washing room. Otherwise, it will affect the normal operation or shorten the service life of the unit, or even cause fire hazard or serious injury. As for above special places, please adopt special air conditioner with anti-corrosive or anti-explosion function.

1.2 Power supply demand

- (1) Provided sufficient capacity of power supply and the cross area of electrical wires.
- (2) Confirm the reliable earth connection, and the earth wire should be connected to special device of the building. Never connect the earth wire to the gas pipe, water pipe, the earth wires of telephone and lighting rod.
- (3) Make sure that the wiring is done by the qualified technicians according to the relevant regulations.
- (4) In fixed circuit, there must be electricity leakage protection switch of enough power capacity and air switch with enough space.
- (5) An all-pole disconnection device which has at least 3mm separation distance in all pole and a residual current device(RCD) with the rating of above 10mA shall be incorporated in the fixed wiring according to the national rule.
- (6) The appliance shall be installed in accordance with national wiring regulations.
- (7) The temperature of refrigerant circuit will be high, please keep the interconnection cable away from the copper tube.

2 Installation of Indoor Unit

2.1 Selection proper installation location

- (1) Avoid the direct sunshine.
- (2) Make sure the suspension bracket is strong enough to withstand the unit's weight.
- (3) Select a place for easily connection of the drain hose.
- (4) The inlet and outlet ports should not be obstructed so that the indoor air circulates well.
- (5) Make sure the convenient connect of the connection pipes.
- (6) Selection a location that is far away from the combustible or explosive material and gas.
- (7) Selection a location that is far away from the cankerous material, fog, dusk or moist.

2.2 Outline Dimension and Installation Spots

Equip with an inspection hatch after lifting the unit. For the convenience of maintenance, the service port should be on one side of the electric box and below unit's lower level.

- (1) Below are the outline dimension applicable to indoor units:

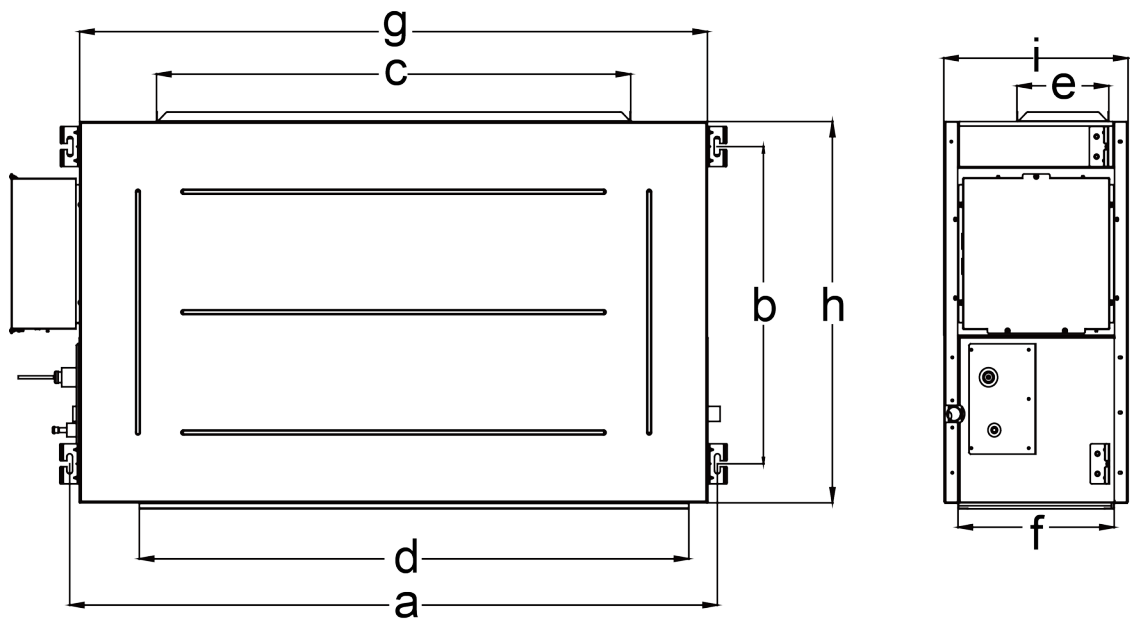

20kW \24kW

Fig. 1

- (2) Below are dimensions of a, b, c, etc. for different models:

Unit: mm

Model	a	b	c	d	e	f	g	h	i
FGR20Pd/DNa-X(Au)(I)	1563	707	962	1350	262	402	1520	840	450
FGR24Pd/DNa-X(Au)(I)	1563	707	962	1350	262	402	1520	840	450

- (3) Drill bolt holes and install bolts.

- 1) Stick the reference cardboard on the installation position; drill 4 holes according to the hole site on the cardboard as shown in Fig 2; diameter of drilling hole is according to the diameter of expansion bolt and the depth is 60-70mm(2-3/8~2-3/4 in.), as shown in Fig 3.

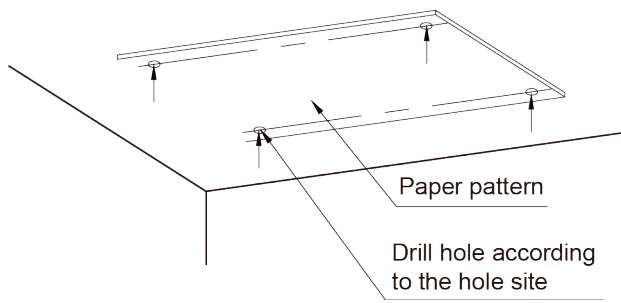

Fig. 2

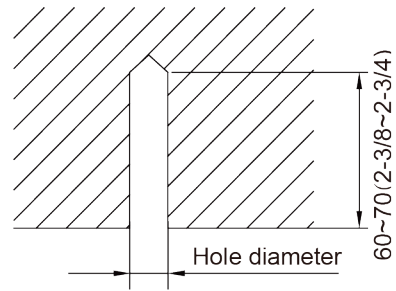

Fig. 3

- 2) Insert the M10 expansion bolt into the hole and then knock the nail into the bolt, as shown in Fig 4.

NOTES!

The length of bolt depends on the installation height of the unit, bolts are field supplied.

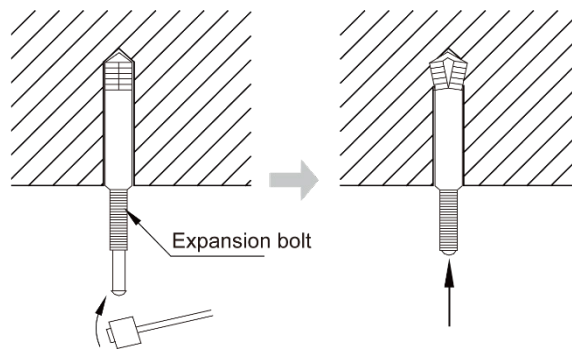

Fig. 4

- (4) Install the indoor unit temporarily.

Assemble suspension bolt on the expansion bolt, attach the hanger bracket to the suspension bolt. Be sure to fix it securely by using a nut and washer from upper and lower sides of the hanger bracket. The washer fixing plate will prevent the washer from falling.

- (5) The usage of paper pattern.

Refer to paper pattern of installation for ceiling opening dimension. The center of ceiling opening is indicated on the paper pattern. Fix the paper pattern to the unit with 4 screws and fix the corners of the waterspout at the drainage pipe by screws.

- (6) Adjust the unit to the right position.

- (7) Check the level of the unit.

The indoor unit is equipped with build-in water pump and float switch, verify the levelness of 4 directions by level gauge or vinyl tube (filled with water) respectively.

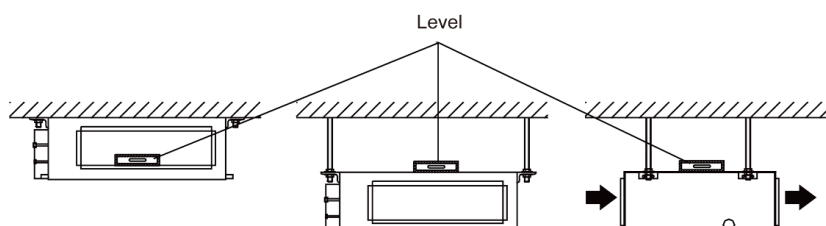

Fig.5

- (8) Remove the washer locating plate and then tighten the nut on it.
- (9) Remove the paper pattern.

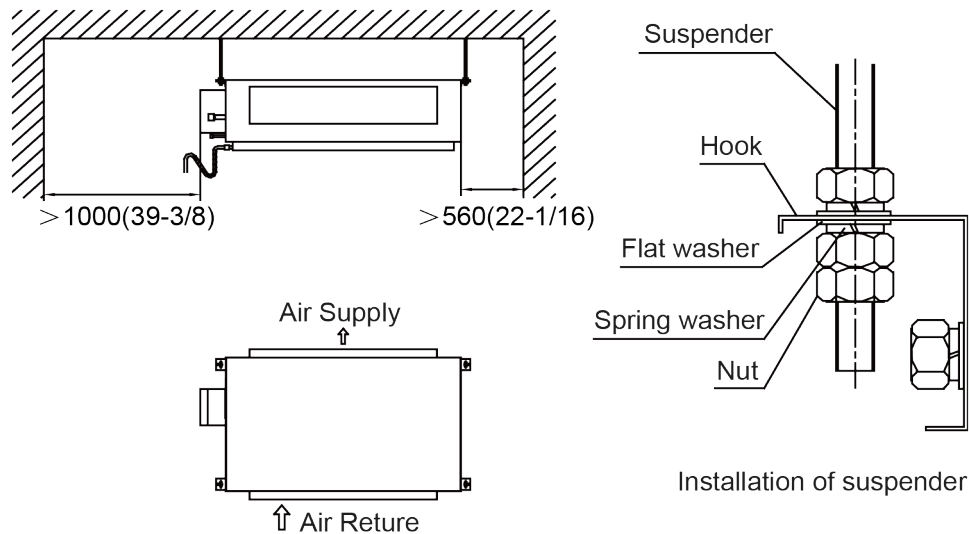

Fig.6

2.3 Drainage Pipe Installation and Drainage System Testing

2.3.1 Notice for Installation of Drain Pipe

- (1) The drainage pipe should be short and the gradient downwards should be at least 1%~2% in order to drain condensation water smoothly.
- (2) The diameter of drainage hose should be bigger or equal to the diameter of drainage pipe joint.
- (3) Install drainage pipe according to the following fig and arrange insulation to the drainage pipe. Improper installation may lead to water leakage and damp the furniture and other things in the room.
- (4) You can buy normal hard PVC pipe used as the drainage pipe. During connection, insert the end of PVC pipe into the drainage hole and then tighten it with drainage hole and wire binder. Can't connect the drainage hole and drainage hole with glue.
- (5) When the drainage pipelines are used for several units, the position of pipeline should be about 100mm (4 in.) lower than the drainage port of each unit. In this case, thicker pipes should be applied.

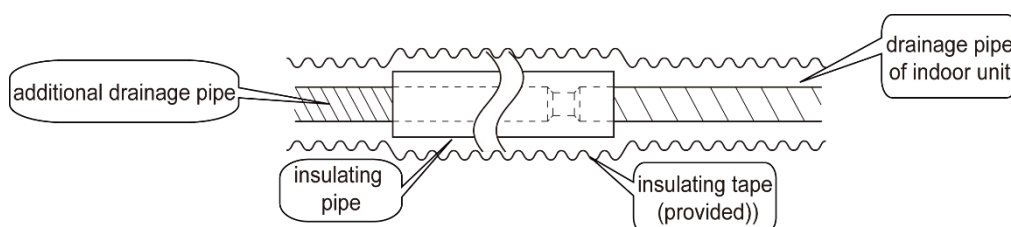

Fig.7

2.3.2 Drainage pipe installation

For easy drainage of the condensation water, the drainage pipe should be installed with a downward gradient. To avoid the condensation, the connection pipe joint should be insulated with

thermal insulation material. A water seal should be employed as shown in Fig.8 and the height of the water seal could be determined by the pressure of the drain hose.

Drain hose is in negative pressure state: $A = B \geq P/10 + 20$ (mm).

Drain hose is in positive pressure state: $A \geq 30\text{mm}$, $B \geq P/10 + 20$ (mm).

Note: P is the absolute pressure of the drain hose position, Pa.

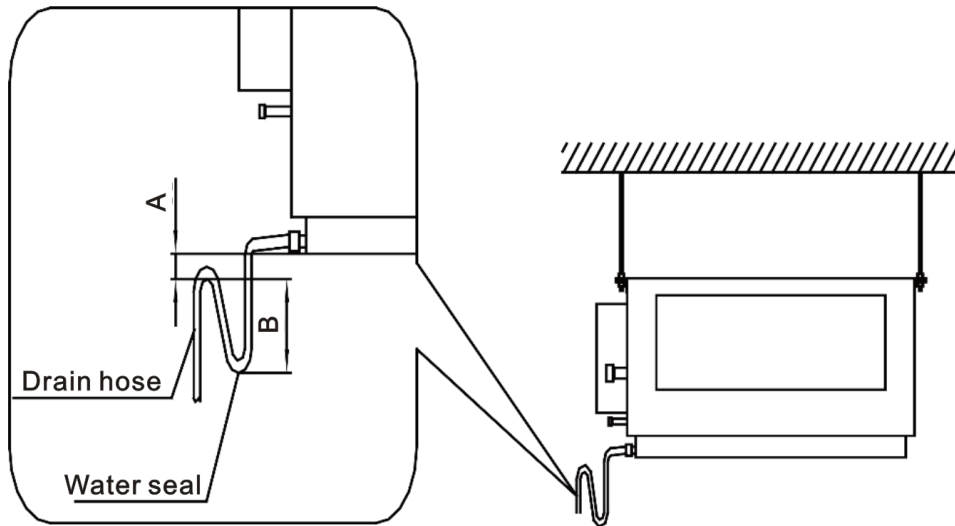

Fig.8

2.3.3 Test of Drainage System

- (1) Inject approximately 1L purified water to drain pan from air vent, ensure that not to splash the water over the electrical components (e.g. water pump. etc.).
- (2) During the test, please carefully check the drainage joint, make sure no any leakage occur.
- (3) It is strongly recommend to do the drain test before ceiling decoration.

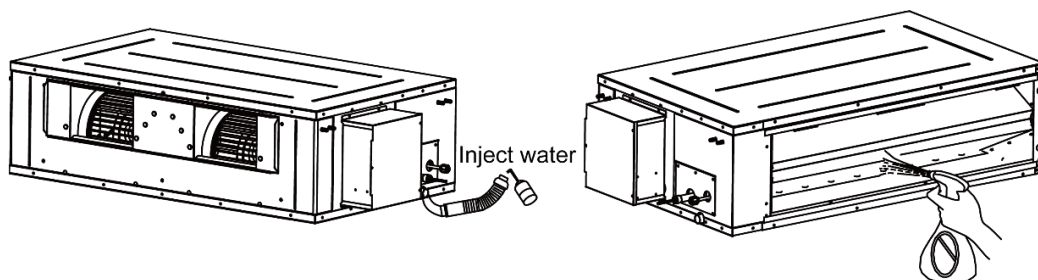

Fig.9

2.4 Installation of Air Duct

! NOTES!

- ① There should be insulating layer on air-out duct, air-return duct and fresh air duct to avoid heat loss and moisture. Adhere a nail on the air duct and then add thermal sponge with a layer of tin. Fasten it with a nail cover and then seal the junction with tin tapes. You can also use other materials that have good insulation quality.
- ② Each air-out duct and air-return duct should be fixed on a pre-made board with iron frame.

The junction of air duct should be well-sealed in order to prevent air leakage.

- ③ The design and construction of air duct should comply with national requirements.
- ④ The edge of air-return duct is suggested to be more than 150mm(5-7/8 in.) away from the wall. Add a filter to the air-return opening.
- ⑤ Please consider noise-damping and vibration damping for the design and construction of air duct. Besides, noise source must be away from people. For instance, do not have the air-return opening installed on top of the user (Offices, rest area, etc.).

2.4.1 Installation of Air-out Duct

(1) Installation of the Rectangular Duct

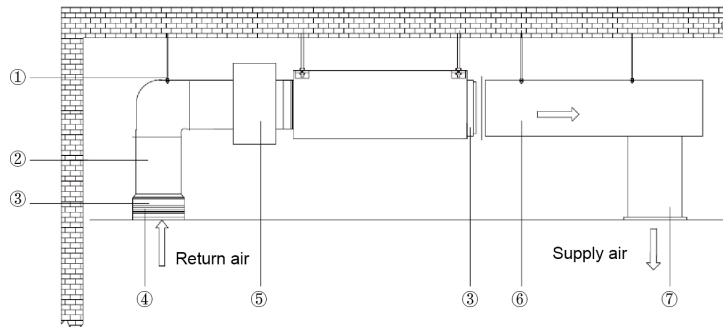

Fig.10

No.	Name	No.	Name
1	Hanger Rod	5	Static Pressure Box
2	Return Air Duct	6	Main Supply Air Duct
3	Canvas Duct	7	Supply Air Outlet
4	Return Air Inlet		

2.4.2 Shape and Size of Air Outlet and Air-return Opening

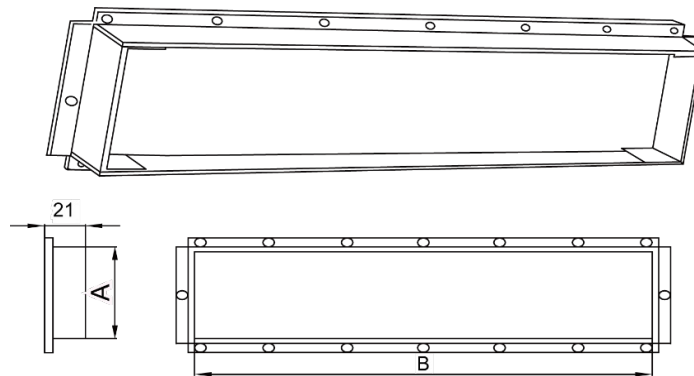

Fig.11 Air Outlet

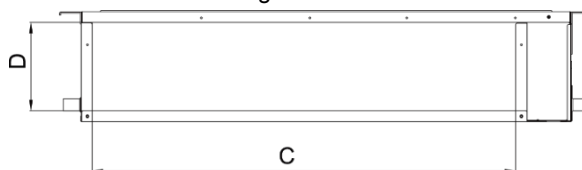

Fig.12 Air-return Opening

Unit: mm

Model	Size of Air Outlet		Size of Air –return Opening	
	A	B	C	D
FGR20Pd/DNa-X(Au)(I)	262	962	1350	402
FGR24Pd/DNa-X(Au)(I)	262	962	1350	402

2.5 Installation of Wired Controller

Please refer to User Manual of Wired Controller for the installation details.

NOTES!

When installation is finished, the unit must be tested and debugged before operation. Please refer to Instruction Manual of ODU for auto addressing and debugging details.

2.6 Wiring Work

WARNING!

Before obtaining access to terminals, all supply circuits must be disconnected.

NOTICE
(1) Units must be earthed securely, or it may cause electric shock.
(2) Please carefully read the wiring diagram before carry out the wiring work, incorrect wiring could cause malfunction or even damage the unit.
(3) The unit should be powered by independent circuit and specific socket.
(4) The wiring should be in accordance with related regulations in order to ensure the units reliable running.
(5) Install circuit breaker for branch circuit according to related regulations and electrical standards.
(6) Keep cable away from refrigerant pipings, compressor and fan motor.
(7) The communication wires should be separated from power cord and connection wire between indoor unit.
(8) Adjust the static pressure via wired controller according to site circumstance.

2.6.1 Connection of Wire and Patch Board Terminal

- (1) The connection of wire (as shown in fig.13).
 - 1) Strip about 25mm (1 in.) insulation of the wire end by stripping and cutting tool.
 - 2) Remove the wiring screws on the terminal board.
 - 3) Shape the tail of wire into ring by needle nose plier, and keep the gauge of ring in accordance with screw.
 - 4) Use the screwdriver for tightening the terminal.
- (2) The connection of stranded wire (as shown in fig.14).
 - 1) Strip about 10mm (3/8 in.) insulation of the end of stranded wire by stripping and cutting tool.
 - 2) Loosen the wiring screws on terminal board.

- 3) Insert the wire into the ring tongue terminal and tighten by crimping tool.
- 4) Use the screwdriver for tightening the terminal.

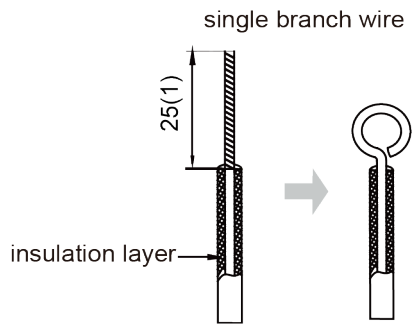

Fig.13

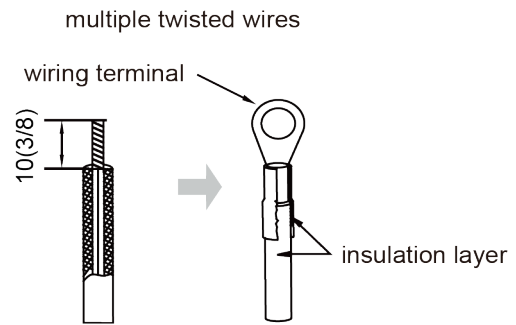

Fig.14

2.6.2 Connect Communication Wire of Wired Controller

- (1) Open electric box cover of indoor unit.
- (2) Let the communication wire go through the rubber ring.
- (3) Connect the communication wire to terminal H1 and H2 of indoor 4-bit wiring board.
- (4) Fix the communication wire with wire clip on the electric box.
- (5) Wiring instructions of remote receiving light board and wired controller:

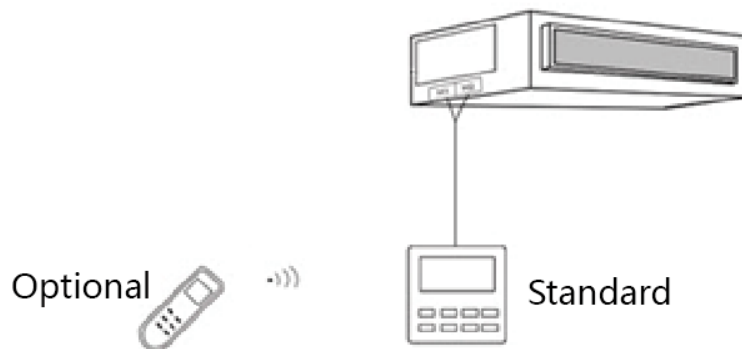

Fig.15

2.6.3 Illustrate for Connection of Wired Controller and Indoor Units Network

- (1) Communication wire of indoor unit and outdoor unit (or indoor unit) is connected to D1, D2.
- (2) Wired controller is connected to H1, H2.
- (3) One indoor unit can connect two wired controllers that must be set as master one and slave one.

3 Installation of Outdoor Unit

! NOTES!

Graphics here are only for reference. Please refer to actual products. Unspecified dimensions are all in mm.

3.1 Dimension of Outdoor Unit and Mounting Hole

Unit Outline and Installation Dimension (mm) .

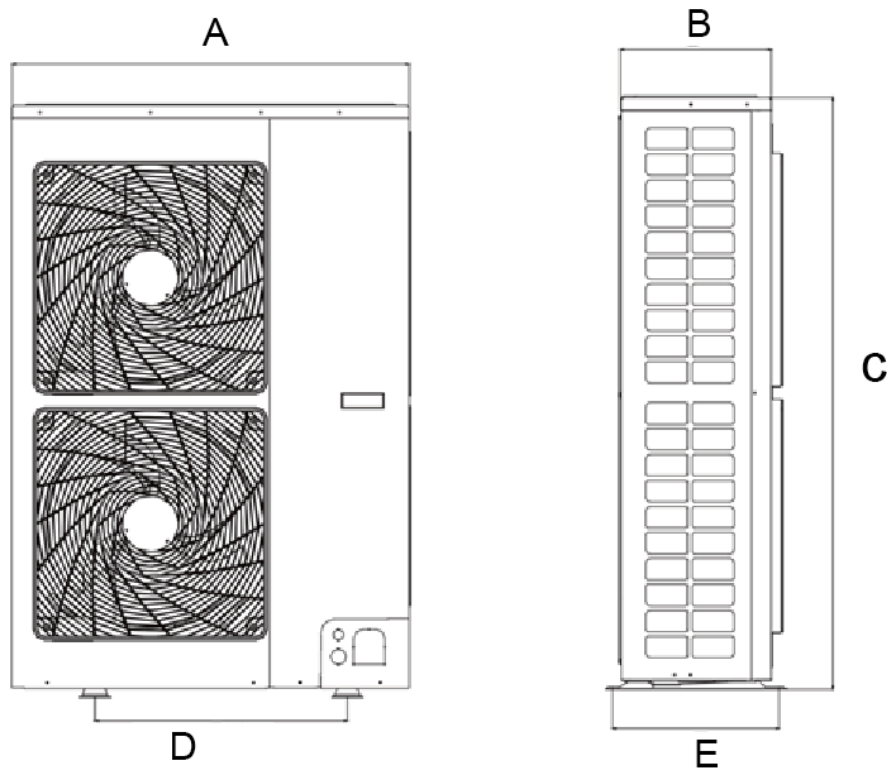

Fig.16

Model	A	B	C	D	E
FGR20Pd/DNa-X(Au)(O)	940	460	1615	610	486
FGR24Pd/DNa-X(Au) (O)	940	460	1615	610	486

Unit: mm

3.2 Installation space requirement

If all sides of the ODU (including the top) are surrounded by walls, process according to the following requirements for installation space:

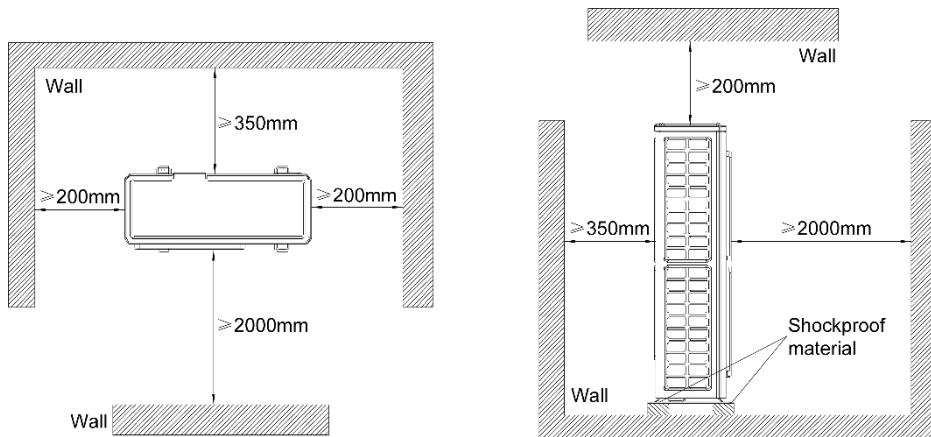

3.3 Refrigerant pipe connection

Note: Do not loosen the cap of the pipes when connecting the pipes between the indoor unit and the outdoor unit. Connecting the pipes as soon as possible after loosening the cap of the pipes to avoid the entering of water and dust. A metal pipe should be utilized if a pipe should be installed through a wall.

The connection of the pipes should confirm to the following principles:

Make sure to lessen the length of connecting pipe, the height difference between the indoor and outdoor unit, and the number of bends, and enlarge the diameter of bends.

The permitted maximum value of each case:

Height difference between the indoor and outdoor unit	<30M
Number of bends	<12
Length of connecting pipes	<50M

The pipe weld type could be employed for the connection of the pipes between the indoor and outdoor units.

The pipe joint should be tightly connected when a pipe joint is employed between two pipes. It is better to use only one connecting pipe if the distance is not far.

The pipes should not be shriveled when the pipes are connecting. The bend diameter should be longer than 200 millimeter. The connecting pipes should not be extended or curved frequently and the curving process should not be larger than 3 times in the same bending position.

During engineering installation, the connection pipe inside the unit must be wrapped by insulation sleeve.

3.4 Vacuum Pumping, Refrigerant Adding

3.4.1 Vacuum Pumping

- (1) Outdoor unit has been charged with refrigerant before delivery. Field-installed connection pipe needs to be charged with additional refrigerant.
- (2) Confirm whether outdoor liquid and gas valves are closed.

- (3) Use vacuum pump to withdraw the air inside indoor unit and connection pipe from the outdoor valve, as shown below.

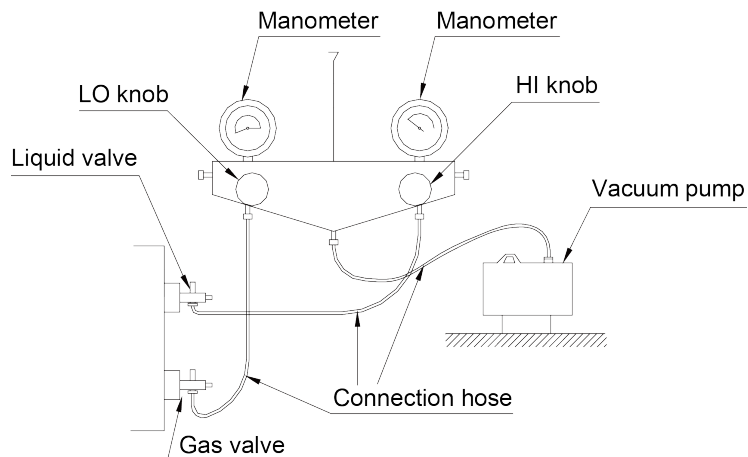

Fig.17

3.4.2 Refrigerant Adding

- (1) Refrigerant quantity of outdoor unit before delivery:

Model	FGR20Pd/DNa-X(Au)(O)	FGR24Pd/DNa-X(Au)(O)
Refrigerant Qty (kg)	6.7	9.5

! NOTES!

- ① The refrigerant amount charged before delivery doesn't include the amount that needs to be added to indoor units and the connection pipeline.
- ② Length of connection pipe is decided on site. Therefore the amount of additional refrigerant shall be decided on site according to the dimension and length of field-installed liquid pipe.
- ③ Record the amount of additional refrigerant for convenience of after-sales service.

- (2) Calculation of the amount of additional refrigerant.

Calculation method of the quantity of additional refrigerant (based on liquid pipe).

Quantity of additional refrigerant = \sum length of liquid pipe X quantity of additional refrigerant per meter.

Quantity of additional refrigerant per meter for liquid pipe (kg/m)					
Φ22.2	Φ19.05	Φ15.9	Φ12.7	Φ9.52	Φ6.35
0.35	0.25	0.17	0.11	0.054	0.022

First confirm that there is no leakage from the system. When compressor is not working, charge additional R410a with specific amount to the unit through the filling opening of the liquid pipe valve of the outdoor unit. If required amount cannot be quickly filled due to pressure increase of the pipe, then set the unit in cooling startup and fill refrigerant from the low pressure check valve of the outdoor unit.

3.5 Electric Wiring

3.5.1 Notices for Wiring

- (1) Install units according to national wiring codes.
- (2) Use air conditioner specialized power supply and make sure that it is consistent with system's rated voltage.
- (3) Do not pull the power cord with force.
- (4) All electrical installation must be performed by qualified technicians in accordance with local laws, regulations and this user manual.
- (5) Caliber of the power cord must be large enough. A damaged power cord or connection wire must be replaced by specialized electrical cords.
- (6) If the supply cord is damaged, it must be replaced by the manufacturer or its service agent or a similarly qualified person in order to avoid a hazard.
- (7) A circuit breaker having a contact separation of at least 3mm in all poles should be fixed in fixed wiring.
- (8) For the wiring of power cord, please refer to the wiring instruction label on the unit.

Connect the unit to specialized grounding device and make sure it is securely grounded. It's a must to install air switch and current circuit breaker that can cut off the power of the entire system. The circuit breaker should include magnetic trip function and thermal trip function so that system can be protected from short circuit and overload.

Grounding Requirements:

- (1) Air conditioner belongs to class I electrical appliance, so it must be securely grounded.
- (2) The yellow-green wire inside the unit is a ground wire. Do not cut it off or secure it with tapping screws, otherwise it will lead to electric shock.
- (3) Power supply must include secure grounding terminal. Do not connect the ground wire to the following:
 - ① Water pipe; ② Gas pipe; ③ Drain pipe; ④ Other places that are deemed as not secure by professional technicians.

3.5.2 Wiring Diagram

(1) Connection of power cord and communication wire.

Separate power supply for IDU and ODU.

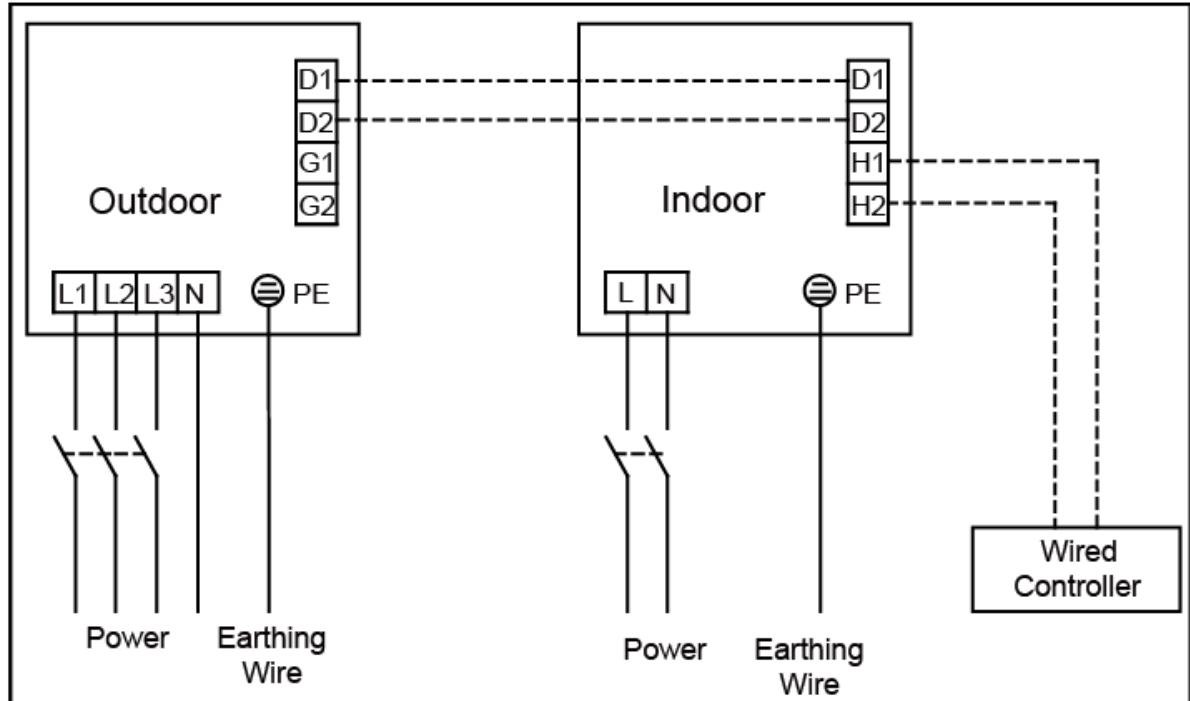

FGR20Pd/DNa-X(Au), FGR24Pd/DNa-X(Au)

Fig.18

(2) Connection of power cord and communication wire for IDU and ODU

Selection of circuit breaker and power cord.

Model	Power supply	Circuit breaker capacity (A)	Number of ground wire * Min sectional area (mm ²)	Number of power cord * Min sectional area (mm ²)
FGR20Pd/DNa-X(Au)(O)	380-415V 3N~ 50/60Hz	32	1*4.0	4*4.0
FGR20Pd/DNa-X(Au)(I)	220V-240V~50/60Hz	/	1*1.5	2*1.5
FGR24Pd/DNa-X(Au)(O)	380-415V 3N~ 50/60Hz	32	1*4.0	4*4.0
FGR24Pd/DNa-X(Au)(I)	220V-240V~50/60Hz	/	1*1.5	2*1.5

NOTES!

- ① Selection of circuit breaker and power cord in the above table is based upon unit's maximum power (maximum current).
- ② Specification of power cord is based on the working condition where ambient temperature is 40°C and multi-core copper cable (working temperature is 90°C, e.g. power cable with YJV cross-linked copper, insulated PE and PVC sheath) is lying on the surface of slot. If working condition changes, please adjust the specification according to national standard.
- ③ Specification of circuit breaker is based on the working condition where ambient

temperature of circuit breaker is 40°C. If working condition changes, please adjust the specification according to national standard.

- ④ The communication wire between the indoor unit and the outdoor unit should wind with a magnetic ring (packed in the packing accessories). The communication wire should wind the magnetic ring for 4 circles, and the use the tieline to fix the magnetic ring at the meta sheet.

4 Check Items after Installation and Test Operation

4.1 Check Items after Installation

Check items	Possible conditions due to improper installation	Check
Each part of the unit is installed securely?	Unit may drop, shake or emit noise.	
Gas leakage test is taken or not?	Insufficient cooling (heating) capacity	
Unit gets proper thermal insulation or not?	There may be condensation and dripping.	
Drainage is smooth or not?	There may be condensation and dripping.	
Is the voltage in accordance with the rated voltage specified on the nameplate?	Unit may have malfunction or components may get damaged.	
is the electric wiring and pipe connection installed correctly?	Unit may have malfunction or components may get damaged.	
Unit is securely grounded or not?	Electrical leakage	
Power cord meets the required specification?	Unit may have malfunction or components may get damaged.	
Is the air inlet/outlet blocked?	Insufficient cooling (heating) capacity	
Length of refrigerant pipe and the charging amount of refrigerant are recorded or not?	The refrigerant charging amount is not accurate.	
Binding pieces on compressor feet are removed or not?	Compressor may get damaged.	

4.2 Test operation and Debugging

NOTES!

- ① After finishing the first installation or replacing the main board of outdoor unit, it is necessary to perform test operation and debugging. Otherwise, unit won't be able to work.
- ② Test operation and debugging must be performed by professional technicians or under the guidance of professional technicians.

4.2.1 Prepare the test operation and Debugging

- (1) Do not connect power until all installation work is finished.
- (2) All control circuits and wires are correctly and securely connected.
- (3) Check whether the fixing loops for compressor foots are removed.
- (4) All small pieces, especially metal chips, thread ends and forceps holder, must be removed from the unit.
- (5) Check whether unit's appearance and pipeline system has been damaged during transportation.
- (6) Calculate the quantity of refrigerant that needs to be added according to the pipe length.

Pre-charge the refrigerant. In case that the required charging quantity is not reached while refrigerant can't be added, record the quantity of refrigerant that still needs to add and complement the quantity during test operation. For details of adding refrigerant during test operation, see below.

- (7) After refrigerant is added, make sure valves of outdoor unit are completely open.
- (8) For the convenience of troubleshooting during debugging, unit shall be connected to a PC with applicable debugging software. Make sure unit's real-time data can be checked through this computer. The installation and connection of debugging software can be found in the Service Manual.
- (9) Before test operation, make sure unit is power on and compressor has been preheated for more than 8 hours. Touch the unit to check whether it's normally preheated. If yes, start test operation. Otherwise, compressor might be damaged.
- (10) If the LED digital tube on main board displays, then input the startup password. For operation details, please see the instructions for the function of startup password.

4.2.2 Test Operation and Debugging

Once the unit is energized and turned on for the first time, the display tube of outdoor unit displays "A0", which indicates debugging standby status. At this time, hold SW3 button successively for 5s on the main module to enter into the automatic debugging, and then the engineering debugging will perform according to the set procedures. Step 3 (confirmation of outdoor unit quantity) and step 4 (confirmation of indoor unit quantity) should be confirmed manually by pressing "SW3", while other procedures will be performed automatically. Once the debugging for each step is finished, "oC" will be displayed; once all engineering debugging are finished, "oF" will be displayed, which indicates the unit is under standby status.

Buttons and digital display tube on the motherboard location:

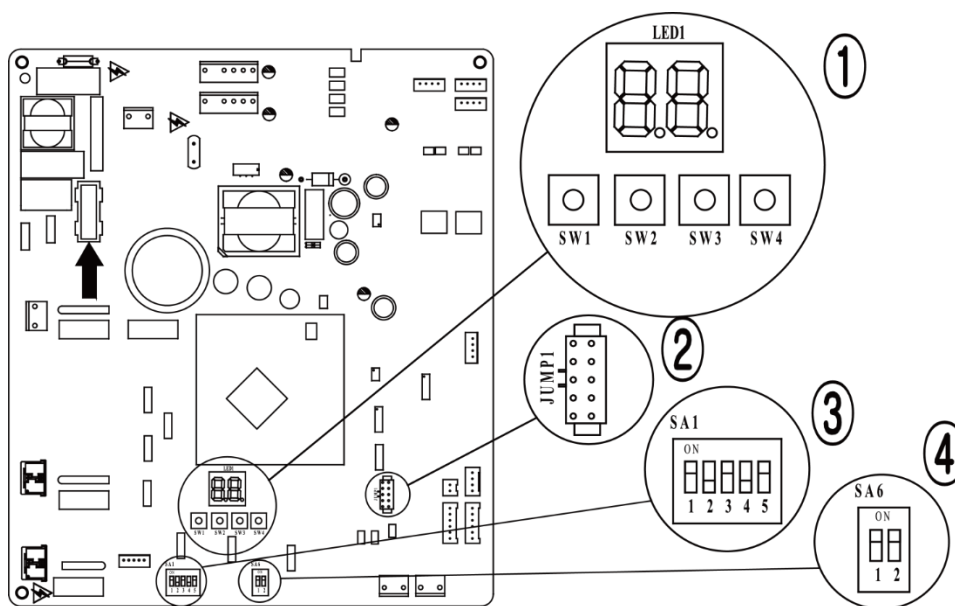

Fig.19

Instruction:

- ① Indicator of main board (digital display tube) “LED1” and four button: “SW1”, “SW2”, “SW3” and “SW4”.

Key No.	SW1	SW2	SW3	SW4
Function	Up	Down	OK	Back

- ② Jumper cap of the unit “JUPM1”, jumper cap No. varies from different type.
- ③ DIP switch “SA1”, DIP switch varies from different cooling capacity, before leaving the factory, DIP switch is set for different models and fixed with glue.
- ④ The main control function DIP switch “SA6” is used to set master module and subsidiary module, the defaulted factory setting is the main module. As the fig is shown, dialing to “ON” side represents “0” and dialing to the figure side represents “1”, the defaulted setting for the unit is “00”. For the system with two outdoor units, one of them shall be set as the

Function	SA6	
	1	2
Master module	0	0
Subsidiary module	1	0



main module, namely, dial “SA6” to “00”, then set the other unit as subsidiary module, namely, dial the “SA6” to “10”.

4.2.2.1 Basic operation of project debugging

- (1) Start project debugging.

Press “SW3” button consecutively in the master module for over 5s to enter auto debugging.

- (2) Exit project debugging.

After entering project debugging, press “SW3” button consecutively in the master module for over 5s to exit the debugging.

- (3) Complete project debugging.

After entering project debugging and completing step “04”, press “SW2” and “SW3” button consecutively in the master module for over 5s to exit the debugging, then the system can operate normally.

Flow-process diagram of debugging:

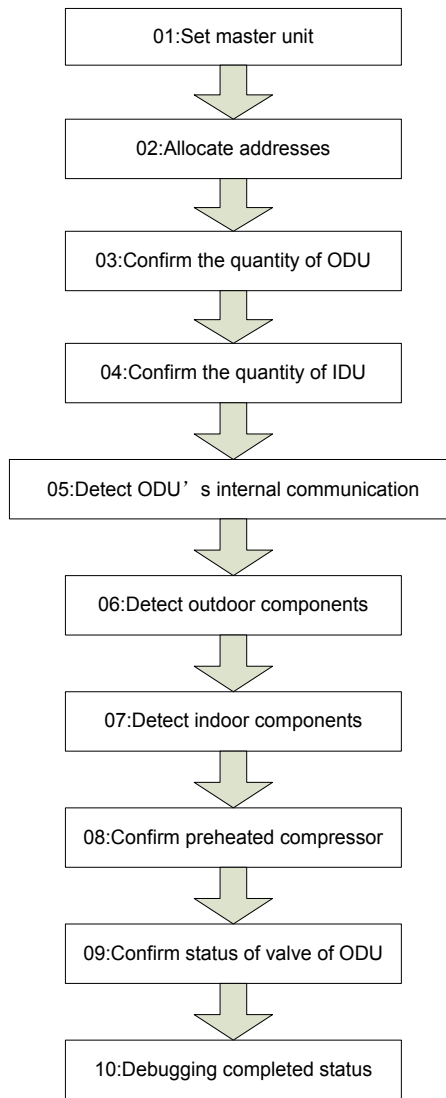

4.2.2.2 Debugging process

(1) Manufacture the unit before Oct 30, 2018.

Debugging procedure for test run, display instruction for indicator on main board of outdoor unit and operation method are as below:

Description of each stage of debugging progress			
Progress	Debugging Code		Instruction for Code and Operating Method
	LED		
	Display Code	Display Code	
Start	A0	Always ON	No debugged yeat. Press "SW3" button consecutively in the master module for over 5s to enter auto debugging.
01_ Set master unit	01/CC	Display repeatedly	There is no master unit in the system. The system cannot continue to conduct debugging, and all the buttons are invalid that must be reset by cutting the power.
	01/CF	Display repeatedly	There are two or more master units in the system. The system cannot continue to conduct debugging, and all the buttons are invalid that must be reset by cutting the power. Please set the correct "SA6" DIP switch.

Description of each stage of debugging progress			
Progress	Debugging Code		Instruction for Code and Operating Method
	LED		
	Display Code	Display Code	
	01/oC	Display repeatedly	There is only one master unit in the system. The unit will automatically enter into the next step after displaying for once.
02_ Allocate addresses	02	Flicker	The system is allocating addresses. It will display as below after 10 seconds.
	02/L7	Display repeatedly	There is no master unit. The display will last for 1 minute, within this 1 minute, the master IDU can be set by debugging software. If the master IDU has not been set within this 1 minute, the system will automatically set the IDU with the minimum IP address as the master IDU.
	02/oC	Display repeatedly	The system has finished allocating the addresses, there is master IDU. It will automatically enter into the next step's operation after displaying for once.
03_ Confirm the quantity of ODU	03/QTY of module	Display repeatedly	Confirmation of quantity of modules in the system. To differentiate from the debugging step, the QTY of module will display only 1-digit on the right. If the actual quantity of ODU is inconformity with the displayed quantity, please check the dial code and wire connection and then conduct debugging for confirmation.
	03/oC	Display repeatedly	If the actual quantity of ODU is in conformity with the displayed quantity, press SW3 button to confirm. After confirmation, all the module nixie tubes will repeatedly display "03" and "0C", after displaying for once, the system will automatically enter into the next operation.
04_ Confirm the quantity of IDU	04/Cb	Display repeatedly	It is not allowed to connect more than one indoor unit in the system. Please check and debug again to confirm.
	04/oC	Display repeatedly	The quantity of IDU in the system has been confirmed. It will enter into the next step.
05_ Detect ODU's internal communication	05/C2	Display repeatedly	Communication error between master control and drive of compressor. Please check if the communication wire between mainboard and driving board of ODU is correctly connected, if it is, enter into the next step. If the ODU should be powered off for the debugging, after re-energizing the unit, please conduct debugging from the above 01 step.
	05/oC	Display repeatedly	The communication between master control and driving of ODU is normal. After displaying for once, it will automatically enter into the next step.
06_ Detect outdoor components	06/corresponding error code	Display repeatedly	Error of components of ODU. After eliminating all the errors, it will automatically enter into the next step. If the ODU should be powered off for the debugging, after re-energizing the unit, please conduct debugging from the above 01 step.
	06/corresponding error code	Display repeatedly	Error of components of ODU. After eliminating all the errors, it will automatically enter into the next step. If the ODU should be powered off for the debugging, after re-energizing the unit, please conduct debugging from the above 01 step.
	06/oC	Display repeatedly	No component of ODU is found in the system, it will enter into the next step 10 seconds later.

Description of each stage of debugging progress			
—	Debugging Code		Instruction for Code and Operating Method
Progress	LED		
	Display Code	Display Code	
07_ Detect indoor components	07/ corresponding error code	Display repeatedly	Error of components of IDU is detected. If the ODU should be powered off for the debugging, after re-energizing the unit, please conduct debugging from the above 01 step.
	07/oC	Display repeatedly	No component of IDU is found in the system. It will automatically enter into the next step 5 seconds later.
08_ Confirm preheated compressor	08/U0	Display repeatedly	Insufficiency preheating of compressor. If the consecutive energization time of all basic modules detected at present is over or equal to 8h, or the discrepancy between the moment when the last consecutive energization time is over or equal to 8h and current time is less than 2h, it means preheat is complete, otherwise, it means preheating is insufficient, direct startup will damage the compressor. At this time, short press SW3 to skip the waiting time to automatically enter the next step.
	08/oC	Display repeatedly	Sufficient preheating of compressor. After displaying once circularly, the system will enter the next step automatically.
09_ Confirm status of valve of ODU	09/oF	Display repeatedly	Standby status, ready to start.
	09/on	Display repeatedly	The system has started.
	09/U6	Display repeatedly	The system shuts down due to malfunction. The error module nixie tube repeatedly display "09" and "U6", other module nixie tubes repeatedly display "09" and "J0". If error occurs, please check if the valve is opened, and at the same time check if the connecting pipes between different modules are correctly connected.
	09/oC	Display repeatedly	Confirmation on valve status is complete. All the modules shut down, then all the module nixie tube will display once.
10_ Debugging completed	OFF	ON	Debugging is completed, the system is in standby status.

(2) Manufacture the unit after Oct 30, 2018.

Debugging procedure for test run, display instruction for indicator on main board of outdoor unit and operation method are as below:

Description of each stage of debugging progress			
—	Debugging code		Instruction for Code and Operating Method
Progress	LED		
	Display code	Display status	
Start	A0	Always ON	No debugged yeat. Press "SW3" button consecutively in the master module for over 5s to enter auto debugging.
01_ Master unit setting	01/CC	Display repeatedly	The system has no master unit. Debugging can't be continued, all buttons are invalid, disconnect the power to reset the correct "SA6" DIP.
	01/CF	Display repeatedly	The system has two or more master units. Debugging can't be continued, all buttons are invalid, disconnect the power to reset the correct "SA6" DIP.
	01/oC	Display repeatedly	The system has only one master unit. After displaying once circularly, the system will enter the next step automatically.

Description of each stage of debugging progress			
Progress	Debugging code		Instruction for Code and Operating Method
	LED		
	Display code	Display status	
02_Address allocation	02	Blink	The system is allocating address, which might takes 10s.
	02/L7	Display repeatedly	No master indoor unit. It will display for 1min continuously. The user can set master through debugging the software within 1min. If no master unit is set manually within 1min, the system will set the indoor unit with the smallest IP address automatically as the master indoor unit.
	02/oC	Display repeatedly	Address allocation of the system is complete with master indoor unit. After displaying once circularly, the system will enter the next step automatically.
03_Confirm quantity of outdoor units	03/ quantity of modules in the system	Display repeatedly	Confirmation of quantity of modules in the system. To differentiate from the debugging step, the QTY of module will display only 1-digit on the right.
	03/oC	Display repeatedly	After 10S, all the nixie tubes of modules will display "03" and "oC", after displaying once circularly, the system will enter the next step automatically.
04_Confirm quantity of indoor units	04/Cb	Display repeatedly	The quantity of indoor unit is more than 1. The system shall not connect more than 1 indoor unit, after inspection, please redebug for confirmation.
	04/oC	Display repeatedly	The quantity of indoor unit is 1. After confirming the quantity of indoor unit, it will enter the next step 2s later.
05_Internal communication of outdoor unit	05/C2	Display repeatedly	Communication error between master control and compressor drive. Please check the connection between the main board of outdoor unit and communication cord of drive board, after eliminating the errors, enter the next step. If the ODU should be powered off for troubleshooting, after re-energizing the unit, please conduct debugging from the above 01 step.
	05/oC	Display repeatedly	Communication between the master control of outdoor unit and drive is normal. After displaying once circularly, the system will enter the next step automatically.
06_Component detection of outdoor unit	06/ Corresponding error code	Display repeatedly	Component error of outdoor unit. After eliminating all the errors, enter the next step automatically, if the ODU should be powered off for troubleshooting, after re-energizing the unit, please conduct debugging from the above 01 step.
	06/oC	Display repeatedly	No component error of outdoor unit. After displaying for 10s circularly, the system will enter the next step automatically.
07_Component inspection of indoor unit	07/ Corresponding error code	Display repeatedly	Component error of indoor unit. After eliminating all the errors, enter the next step automatically, if the ODU should be powered off for troubleshooting, after re-energizing the unit, please conduct debugging from the above 01 step.
	07/oC	Display repeatedly	No component error of indoor unit After displaying for 5s circularly, the system will enter the next step automatically.
08_Preheat confirmation of compressor	08/oC	Display repeatedly	After displaying for 2s circularly, the system will enter the next step automatically.

Description of each stage of debugging progress			
Progress	Debugging code		Instruction for Code and Operating Method
	LED		
	Display code	Display status	
09_ Confirmation of valve of outdoor unit	09/oF	Display repeatedly	Standby status, ready to start.
	09/on	Display repeatedly	The system has started.
	09/U6	Display repeatedly	Malfunction shutdown. The nixie tube of faulted module will display "09" and "U6" repeatedly and the nixie tube of other modules will display "09" and "J0". In canse malfunction occurd, please check if the valve is opened and if the connection pipes among different modules are correctly connected.
	09/oC	Display repeatedly	Confirmation of valve status All modules are halted normally, nixie tubes of all modules will display once circularly.
10_ Debugging completed	OFF	ON	Debugging is completed, the system is in standby status.

5 Common Malfunctions and Troubleshooting



WARNING!

- ① If there is abnormal condition (e.g. unpleasant smell), turn unit off and disconnect power immediately. Then contact Gree authorized service center. If unit continues operation despite the abnormal condition, it may get damaged and lead to electric shock or fire hazard.
- ② Do not repair the air conditioner by yourself. Improper maintenance may lead electric shock or fire hazard. Please contact Gree authorized service center for maintenance.

Please check the items below before calling for maintenance.

Problems	Causes	What to do
Unit doesn't work.	Fuse or circuit breaker is cut off.	Replace fuse or reset the circuit breaker.
	Power failure.	Restart unit when power is restored.
	Power is not connected.	Connect the power.
	Remote controller's power is not enough.	Replace new battery.
	Remote controller is out of the control range.	Control range is within 8m.
Unit runs but stops immediately.	Air inlet or air outlet of indoor and outdoor units is blocked.	Clear obstructions.
Abnormal cooling or heating.	Air inlet or air outlet of indoor and outdoor units is blocked.	Clear obstructions.
	Improper temp setting.	Adjust setting at remote controller or wired controller.
	Fan speed is set too low.	Adjust setting at remote controller or wired controller.
	Wind direction is not correct.	Adjust setting at remote controller or wired controller.
	Door or window is open.	Close the door or window.
	Direct sunshine.	Draw curtain or louver.
	Too many people in the room.	
	Too many heat resources in the room.	Reduce heat resources.
	Filter is blocked and dirty.	Clean the filter.

 **NOTES!**

If problem cannot be solved after checking the above items, please contact Gree service center and describe the cases and models.

Following circumstances are not malfunctions.

Malfunction		Reason
Unit doesn't run.	Unit starts up immediately after it is turned off.	Overload protection switch makes it run after a 3-min delay.
	Power is just turned on.	Standby operation lasts for about 1min.
Mist comes from the unit.	Under cooling.	Indoor air with high humidity is cooled rapidly.
Noise is emitted.	Slight cracking sound is heard when unit is just turned on.	It is the noise when electronic expansion valve is initialized.
	There is consecutive sound when cooling.	It is the sound for gas refrigerant flowing in the unit.
	There is sound when unit starts or stops.	It is the sound when gas refrigerant stops flowing.
	There is slight and consecutive sound when unit is running or after running.	This is the sound of drainage operation.
	Cracking sound is heard when unit is running or after running.	This is the sound caused by the expansion of panel and other parts of the unit due to temperature change.
Unit blows out dust.	Unit starts up after not operating for a long time.	Dust in indoor unit is blown out.
Unit emits odor.	Under operation.	Unit absorbs the room odor and then blows it out.

6 Error Indication

Inquiry method of error indication: combine division symbol and content symbol to check the corresponding error.

For example, division symbol L and content symbol 4 together means over-current protection.

Indoor unit:

Error Code	Content	Error Code	Content
L0	Malfunction of IDU (uniform)	L1	Protection of indoor fan
L2	Auxiliary heating protection	L3	Water-full protection
L4	Wired Controller Power Supply Error	L5	Freeze prevention protection
L6	Mode shock	L7	No main IDU
L8	Power supply is insufficient	L9	1-to-more: number of IDU is inconsistent
LA	1-to-more: IDU series is inconsistent	LH	Alarm due to bad air quality (Fresh air unit)
LC	Models for IDU and ODU are not matched	EC	Drop protection of discharge temperature sensor of compressor 1
d1	Indoor PCB is poor	d3	Malfunction of ambient temperature sensor
d4	Malfunction of entry-tube temperature sensor	d5	Malfunction of middle temperature sensor
d6	Malfunction of exit-tube temperature sensor	d7	Malfunction of humidity sensor
d9	Malfunction of jumper cap	dA	Web address of IDU is abnormal
dH	PCB of wired controller is abnormal	dC	Abnormal setting for capacity button
dL	Malfunction of air-outlet temperature sensor(Fresh air unit)	dE	Malfunction of indoor CO ₂ sensor (fresh air unit)
FP	Malfunction of DC motor	J7	Gas-mixing protection of 4-way valve
J8	High pressure ratio protection of system	J9	Low pressure ratio protection of system
JA	Protection due to abnormal pressure	JL	High-pressure protection
b6	Malfunction of inlet temp sensor of gas-liquid separator	b7	Malfunction of outlet temp sensor of gas-liquid separator
b9	Malfunction of heat exchanger temperature sensor	bH	Clock of system is abnormal
P6	Drive IPM module protection of compressor	P7	Malfunction of drive temperature sensor of compressor
P8	Drive IPM high temperature protection of compressor	P9	Desynchronizing protection of inverter compressor
PH	High-voltage protection of compressor's drive DC bus bar	PC	Drive current detection circuit malfunction of compressor
PL	Low-voltage protection of compressor's drive DC bus bar	PE	Phase-lacking of inverter compressor
PF	Drive charging circuit malfunction of compressor	PJ	Failure startup of inverter compressor
PP	AC current protection of inverter compressor	H6	Drive IPM module protection of fan
H7	Malfunction of drive temperature sensor of fan	H8	Drive IPM high temperature protection of fan
H9	Desynchronizing protection of inverter fan	HH	High-voltage protection of fan's drive DC bus bar
HC	Drive current detection circuit malfunction of fan	HL	Low-voltage protection of fan's drive DC bus bar
HE	Phase-lacking of inverter fan	HF	Drive charging circuit malfunction of fan
HJ	Failure startup of inverter fan	HP	AC current protection of inverter fan

Outdoor:

Error Code	Content	Error Code	Content
E0	Malfunction of ODU (uniform)	E1	High-pressure protection
E2	Discharge low-temperature protection	E3	Low-pressure protection
E4	High discharge temperature protection of compressor	E5	High discharge temperature protection of compressor 1
F0	Main board of ODU is poor	F1	Malfunction of high-pressure sensor
F3	Malfunction of low-pressure sensor	F5	Malfunction of discharge temperature sensor of compressor 1
J1	Over-current protection of compressor 1	b1	Malfunction of outdoor ambient temperature sensor
b2	Malfunction of defrosting temperature sensor 1	b4	Malfunction of liquid temperature sensor of sub-cooler
b5	Malfunction of gas temperature sensor of sub-cooler	P0	malfunction of driving board of compressor (uniform)
P1	Driving board of compressor operates abnormally (uniform)	P2	Voltage protection of driving board power of compressor (uniform)
P3	Reset protection of driving module of compressor	P4	Drive PFC protection of compressor
P5	Over-current protection of inverter compressor	H0	Malfunction of driving board of fan (uniform)
H1	Driving board of fan operates abnormally (uniform)	H2	Voltage protection of driving board power of fan (uniform)
H3	Reset protection of driving module of fan	H4	Drive PFC protection of fan
H5	Over-current protection of inverter fan		

Debugging:

Error Code	Content	Error Code	Content
U0	Preheat time of compressor is insufficient	U2	Wrong setting of ODU's capacity code/jumper cap
U4	Refrigerant-lacking protection	U5	Wrong address for driving board of compressor
U6	Alarm because valve is abnormal	U8	Short-circuit malfunction of IDU
U9	Malfunction of pipe-line for ODU	UC	Setting of main IDU is successful
UL	Wrong button-dial	UE	Charging of refrigerant is invalid
C0	Communication malfunction between IDU, ODU and IDU's wired controller	C2	Communication malfunction between main control and inverter compressor driver
C3	Communication malfunction between main control and inverter fan driver	C4	Malfunction of lack of IDU
C5	Alarm because project code of IDU is inconsistent	C8	Emergency status of compressor
C9	Emergency status of fan	CH	Rated capacity is too high
CC	Malfunction of lack of main control unit	CL	Rated capacity is too low
CF	Malfunction of multiple main control units	CJ	Malfunction of multiple main wired controllers
CP	Malfunction of multiple main wired controllers	CU	Communication malfunction between IDU and the receiving lamp plate
Cb	Overflow distribution of IP address		

Status:

Error Code	Content	Error Code	Content
A0	Unit waiting for debugging	A1	Inquiry of compressor operation parameters
A2	Refrigerant recovery operation of after-sales	A3	Defrosting
A4	Oil-return	A5	Online test
A6	Heat pump function setting	A7	Quiet mode setting
A8	Vacuum pump mode	A9	IPLV test
AA	EU AA level EER test mode	AH	Heating
AC	Cooling	AL	Charging refrigerant automatically
AE	Charging refrigerant manually	AF	Fan
AJ	Alarm for cleaning filter	AP	Debugging confirmation for startup of unit
AU	Long-distance emergency stop	Ab	Emergency stop of operation
Ad	Limit operation	n0	SE operation setting of system
n1	Setting of defrosting cycle K1	n2	Setting of upper limit of IDU/ODU capacity distribution ratio
n4	Limit setting for max. capacity/output capacity	n6	Inquiry of project code of IDU
n7	Inquiry of malfunction	n8	Inquiry of parameters
nA	Heat pump unit	nH	Heating only unit
nC	Cooling only unit	nE	Negative sign code
nF	Fan model		

7 Maintenance and Care

Regular check, maintenance and care can extend unit's service life. Please have specialized person in charge of the management of air conditioners.

7.1 Outdoor Heat Exchanger

Outdoor heat exchanger shall be cleaned regularly, which is at least once every two months. You can use a dust catcher with nylon brush to clean away the dust on the heat exchanger. If compressed air source is available, it also can be used to clean the heat exchanger. Do not clean it with water.

7.2 Drain Pipe

Please check regularly whether drain pipe is blocked or not. Make sure condensate can be drained out smoothly.

7.3 Notice before Seasonal Use

- (1) Check whether air inlets and air outlets of indoor and outdoor units are blocked;
- (2) Check whether ground connection is reliable or not;
- (3) Check whether batteries in the remote controller are replaced or not;
- (4) Check whether air filter is properly installed;
- (5) If unit starts up after not operating for a long time, it should be power on 8 hours before operation starts so as to preheat the outdoor compressor;
- (6) Check whether outdoor unit is securely installed. If there is any problem, please contact Gree authorized service center.

7.4 Maintenance after Seasonal Use

- (1) Disconnect power of the entire system;
- (2) Clean the air filter and outer case of indoor and outdoor units;
- (3) Clean away the dust and obstacles on indoor and outdoor units;
- (4) If outdoor unit has rust, please apply some paint to it so as to prevent the rust from growing.

7.5 Parts Replacement

Parts and components can be obtained from nearby Gree office or Gree distributor.

NOTES!

When you are conducting air tightness test and leakage test, do not mix oxygen, C2H2 or other dangerous gas into the refrigerant circuit. Otherwise, it may lead to danger. Use nitrogen or refrigerant to conduct the tests.

8 After-sales Service

If there's quality defect or other problems in the product, please contact Gree local after-sales service department for help.

Warranty must be based on the following conditions:

- (1) Product's initial startup must be performed by professional technicians from Gree service center or persons assigned by Gree.
- (2) Only Gree spare parts are used.
- (3) All instructions of unit operation and maintenance in this manual must be strictly followed according to set period and set frequency.
- (4) Any breach of the above conditions will disable the warranty.

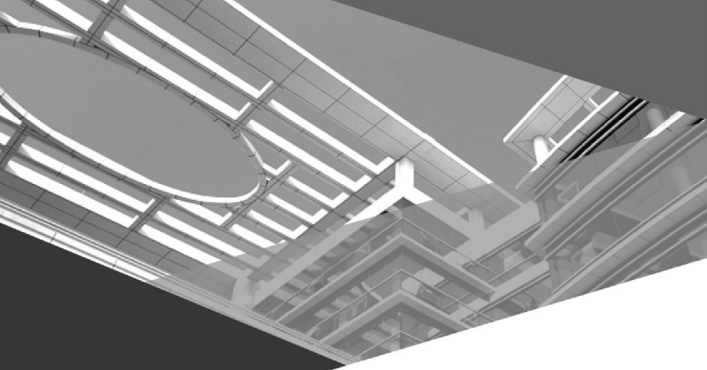

GREE ELECTRIC APPLIANCES, INC. OF ZHUHAI

Add: West Jinji Rd, Qianshan, Zhuhai, Guangdong, China, 519070

Tel: (+86-756) 8522218

Fax: (+86-756) 8669426

E-mail: gree@gree.com.cn www.gree.com



600005060720