

# Dual temperature controller

## XLR460

### COOL MATE

### Operating Manual



## COOLMATE

## XLR460

## INDICE

1. GENERAL WARNINGS	3
2. GENERAL DESCRIPTION	3
3. TEMPERATURE CONTROL	3
4. DEFROST	3
5. CONTROL OF EVAPORATOR FANS (ONLY FOR SECTION 1)	4
6. DISPLAY	5
7. PARAMETER LIST	7
8. DIGITAL INPUT	10
9. INSTALLATION AND MOUNTING	11
10. DIMENSIONS	13
11. ELECTRICAL CONNECTIONS	13
12. HOW TO USE THE HOT KEY	13
13. ALARM SIGNALS	13
14. TECHNICAL DATA	14
15. WIRING CONNECTIONS	14
16. DEFAULT SETTING VALUES	14

## 1. GENERAL WARNINGS

### 1.1 PLEASE READ BEFORE USING THIS MANUAL

- This manual is part of the product and should be kept near the instrument for easy and quick reference.
- The instrument shall not be used for purposes different from those described hereunder. It cannot be used as a safety device.
- Check the application limits before proceeding.

### 1.2 SAFETY PRECAUTIONS

- Check the supply voltage is correct before connecting the instrument.
- Do not expose to water or moisture: use the controller only within the operating limits avoiding sudden temperature changes with high atmospheric humidity to prevent formation of condensation
- Warning: disconnect all electrical connections before any kind of maintenance.
- Fit the probe where it is not accessible by the End User. The instrument must not be opened.
- In case of failure or faulty operation send the instrument back to the distributor or to "Dixell s.r.l." (see address) with a detailed description of the fault.
- Consider the maximum current which can be applied to each relay (see Technical Data).
- Ensure that the wires for probes, loads and the power supply are separated and far enough from each other, without crossing or intertwining.
- In case of applications in industrial environments, the use of mains filters (our mod. FT1) in parallel with inductive loads could be useful.

## 2. GENERAL DESCRIPTION

Model **XR460C**, 32x74 mm format, is a microprocessor based controller, able to control 2 temperatures in an independent way.

The **first section** is suitable for applications on medium or low temperature refrigerating units. It is provided with 3 relay outputs to control compressor, defrost - which can be either electrical or hot gas - and the evaporator fans. It is also provided with 2 NTC or PTC probe inputs, one for temperature control the other one to control the defrost end temperature of the evaporator.

The **second section** is suitable for applications on medium or normal temperature refrigerating units, with timed defrost. It's provided with 1 relay output to control compressor. It is also provided with 1 NTC/PTC probe inputs, for temperature control.

There are two digital inputs (free contact) completely configurable by parameter.

The standard TTL output allows the user to connect, by means of a TTL/RS485 external module, a **ModBUS-RTU** compatible monitoring system and to programme the parameter list with the "**Hot Key**".

## 3. TEMPERATURE CONTROL

### 1. THE COMPRESSOR 1 (2)

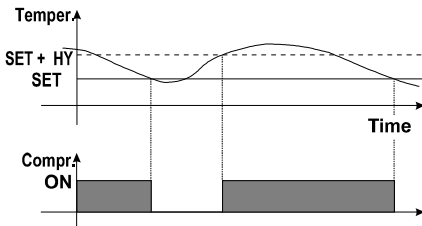

For each section, the regulation is performed according to the temperature measured by its own thermostat probe with a positive differential from the set point.

If the temperature increases and reaches set point1 (2) plus differential1 (2) the compressor is started and then turned off when the temperature reaches the set point value again.

In case of fault in the thermostat probe the start and stop of the compressor are timed through parameters "**CO1(2)**" and "**COF1(2)**".

## 4. DEFROST

### 1. SECTION 1

For the **section 1** two defrost modes are available through the "**tdF1**" parameter:

**tdF1= rE** defrost with electrical heater

**tdF1= in** or hot gas.

The defrost interval is control by means of parameter "**EdF**":

**rtc (only for instruments with RTC)**: beginning of defrost cycles is set by the **L1d1+L1d6** parameters during the working days and **S1d1+S1d6** during the holidays

**in** the defrost is made every "**IdF**" time

**Sd** the interval "**IdF**" is calculate through Smart Defrost algorithm (only when the compressor is ON)

At the end of defrost the drip time is controlled through the "**Fdt**" parameter.

## 2. SECTION 2

For the **section 2** the defrost interval is control by means of parameter "**EdF2**": with EdF=in the defrost is made every "**IdF2**" time, with EdF2=Sd the interval "**IdF2**" is calculate through Smart Defrost algorithm (only when the compressor 2 is ON).

Defrost is performed through a simple stop of the compressor2. Parameter "**IdF2**" controls the interval between defrost cycles, while its length is controlled by parameter "**MdF2**".

## 3. RELATION BETWEEN DEFROSTS

Different kinds of defrosts are available for each section.

The relation between defrosts is set by the **dFS** parameter: **relation between defrosts**.

4 relation between the 2 sections of the controller are available, to manage different kinds of applications:

**in** = independent defrosts;

**StS** = same defrost start, synchronised defrost end;

**St** = same defrost start, independent defrost end;

**SE** = sequential defrost;

- **dFS= in - independent defrosts**

The defrosts of the 2 sections of controller are completely independent.

**First section:** defrost interval is set by **idF1** parameter.

**Second section:** defrost interval is set by **idF2** parameter.

The defrost interval is control by means of parameter "**EdF1(2)**":

**in** the defrost is made every "**IdF**" time

**Sd** the interval "**IdF**" is calculate through Smart Defrost algorithm (only when the compressor is ON)

Manual defrost activation, by pushing the DOWN key (defrost 1) or UP key (defrost 2).

By pushing the Down key or Up key for 3s, a defrost request is generated for section 1 or 2 respectively. The defrost interval is re-loaded.

- **dFS = StS – Same defrost start, end defrost synchronised or dFS = St - Same defrost start, end defrost independent.**

The defrost of the 2 sections of controller starts at the same time. **idF1** parameter sets the defrost interval for both the sections. The defrosts are performed at regular interval if EdF1 = in or according to the Smartdefrost algorithm if EdF1 = Sd.

With **dFS = StS** regulation restarts only when defrost is finished for both the sections. The section that finishes the defrost before the other starts dripping time until also the other section has not finished its defrost.

Manual defrost activation, by pushing the DOWN key (defrost 1) or UP key (defrost 2).

By pushing the Down key or Up key for 3s, a defrost request is generated for both the sections 1 and 2. The defrost interval is re-loaded.

With **dFS = St** each section restarts regulation as soon as its defrost is finished.

- **dFS = SE – sequential defrost**

The defrost of 2 sections is synchronised. **idF1** parameter sets the defrost interval for both the sections. Defrosts are performed at regular interval if EdF1 = in or according to the Smartdefrost algorithm if EdF1 = Sd. Section 1 does its defrost first, at the end of the defrost of section 1, section 2 starts its defrost.

Manual defrost activation, by pushing the DOWN key (defrost 1) or UP key (defrost 2).

By pushing the Down key or Up key for 3s, a defrost request is generated for both the sections 1 and 2. The defrost interval is re-loaded.

## 5. CONTROL OF EVAPORATOR FANS (ONLY FOR SECTION 1)

Section 1 has 1 relay to control evaporator fan.

The fan control mode is selected by means of the "**FnC1**" parameter:

**FnC1=C-n** fans will switch ON and OFF with the compressor and **not run** during defrost;

**FnC1=O-n** fans will run continuously, but not during defrost

After defrost, there is a timed fan delay allowing for drip time, set by means of the "**Fnd1**" parameter.

**FnC1=C-y** fans will switch ON and OFF with the compressor and **run** during defrost;

**FnC1=O-y** fans will run continuously also during defrost

An additional parameter "**FS1**" provides the setting of temperature, detected by the evaporator probe, above which the fans are always OFF. This can be used to make sure circulation of air only if his temperature is lower than set in "FS1".

## 6. DISPLAY



## 1.3 THE KEYBOARD

SET 1

To display and modify target set point 1. During programming it selects a parameter or it confirms a value.

SET 2

To display and modify target set point 2



In programming mode it browses the parameter codes or decreases the displayed value. By holding it pressed for 3s the defrost for section 1 is started



In programming mode it browses the parameter codes or increases the displayed value. By holding it pressed for 3s the defrost for section 2 is started.



It activates light 1



It activates light 2



Section 1 Stand-by



Section 2 Stand-by

## KEYS COMBINATIONS



+



To lock and unlock the keyboard.



+



To enter the programming mode.











+



To exit the programming mode.

## 1.4 MEANING OF THE ICONS



ICON	FUNCTION	MEANING
°C	ON	Celsius degree
°F	ON	Fahrenheit degree
❄️ <sub>1</sub>	ON	Compressor 1 on

 1	FLASHING	Anti-short cycle delay enabled for compressor 1
 2	ON	Compressor 2 on
 2	FLASHING	Anti-short cycle delay enabled for compressor 2
 1	ON	Defrost 1 in progress
 1	FLASHING	Drip time in progress for section 1
 2	ON	Defrost 2 in progress
 1	ON	Fan enabled
 1	FLASHING	Drip time in progress
	ON	ALARM signal

### 1.5 HOW TO SEE AND MODIFY THE SET-POINT

Push and release the **SET1** or **SET2** key:  
the **bottom display** shows the label **St1** or **St2**  
the **upper display** shows the Set point value flashing  
To change the Set value push the **▲** or **▼** within 15s.  
To memorise the new set point value push the **SET1** or **SET2** key again or wait 15s.

### 1.6 HOW TO START A MANUAL DEFOST FOR THE SECTION 1 OR SECTION 2

To start a defrost for the **section 1**: push the **DOWN** key( **1**) for 3s.  
To start a defrost for the **section 2**: push the **UP** key( **2**) for 3s.

### 1.7 HOW TO ENTER THE "PR1" PARAMETER LIST

To change the parameter's value operate as follows:  
Enter the Programming mode by pressing the **Set1** and **DOWN** key for 3s  
The controller will show the first parameter present in the Pr1 menu:  
Bottom menu: label  
Upper menu: value  
**To exit:** Press **SET + UP** or wait 15s without pressing a key.

### 1.8 HOW TO ENTER IN PARAMETERS LIST "PR2"

To access parameters in "Pr2":  
Enter the "Pr1" level.  
Select "Pr2" – "PAS" parameter and press the **"SET1"** key.  
The flashing value "0 - -" is displayed. use **▲** or **▼** to input the security code and confirm the figure by pressing **"SET"** key.  
The security code is "321".  
If the security code is correct the access to "Pr2" is enabled by pressing **"SET1"** on the last digit.

Another possibility is the following:  
After switching ON the instrument, within 30 seconds, push **SET1 + ▼** keys together for 3s: the Pr2 menu will be entered.

### 1.9 HOW TO MOVE A PARAMETER FROM THE "PR2" MENU TO "PR1" AND VICE VERSA.

Each parameter present in "Pr2" MENU can be removed or put into "Pr1", user level, by pressing **"SET1 + ▼"**.  
In "Pr2" when a parameter is present in "Pr1" the decimal point LE of the bottom display is on.

### 1.10 HOW TO CHANGE A PARAMETER

To change a parameter value operates as follows:  
Enter the Programming mode  
Select the required parameter.  
Press the **"SET1"** key and the value starts blinking.  
Use **"UP"** or **"DOWN"** to change its value.  
Press **"SET1"** to store the new value and move to the following parameter.

**TO EXIT:** Press **SET1 + ▲** or wait 15s without pressing a key.

**NOTE:** the set value is stored even when the procedure is exited by waiting the time-out to expire.

### 1.11 HOW TO LOCK THE KEYBOARD



Keep pressed for more than 3 s the ▲ and ▼ keys.

The "POF" message will be displayed and the keyboard will be locked. At this point it will be possible only to see the set points.

If a key is pressed more than 3s the "POF" message will be displayed.

### 1.12 TO UNLOCK THE KEYBOARD

Keep pressed together for more than 3s the ▲ and ▼ keys, till the "Pon" message will be displayed.

### 1.13 ON/OFF FUNCTION – HOW TO SWITCH ON AND OFF THE CONTROLLER

If the function is enabled (par. **onF=yES**), by pressing the **SET1** key for more than 5s the controller is switched OFF. The stand-by function switches OFF all the relays and stops the regulation. During the stand by if a monitored unit is connected, it does not record the instrument data and alarms. To switch the instrument on again press the SET1 key for 5s.

**NOTE1:** When the instrument is under Stand-by, all the relays are under power supply. Don't connect any loads to the normal closed contact of the relays.

**NOTE2:** With the instrument in stand-by, it's possible to see and modify the set points and enter the programming mode.

## 7. PARAMETER LIST

### DIFFERENTIALS

- Hy1 Differential1:** (0,1+25,5°C; 1+45°F): Intervention differential for set point1, always positive. Compressor1 Cut IN is Set Point Plus Differential1 (Hy1). Compressor1 Cut OUT is when the temperature reaches the set point1.
- Hy2 Differential2:** (0,1+25,5°C; 1+45°F): Intervention differential for set point2, always positive. Compressor2 Cut IN is Set Point2 Plus Differential2 (Hy2). Compressor2 Cut OUT is when the temperature reaches the set point2.

### REGULATION – SECTION 1

- LS1 Minimum set point1 limit:** (-50,0°C+SET1; -58°F+SET1) Sets the minimum acceptable value for the set point1.
- US1 Maximum set point1 limit:** (SET1+110°C; SET1+230°F) Set the maximum acceptable value for set point1.
- OdS1 Outputs activation delay of section 1 at start up:** (0+255 min) This function is enabled at the initial start up of the instrument and inhibits any output activation of the section 1 for the period of time set in the parameter. (Light can work)
- AC1 Anti-short cycle delay for compressor1:** (0+30 min) interval between the compressor1 stop and the following restart.
- Con1 Compressor1 ON time with faulty probe1:** (0+255 min) time during which the compressor1 is active in case of faulty thermostat probe. With CO<sub>n</sub>=0 compressor1 is always OFF.
- COF1 Compressor1 OFF time with faulty probe1:** (0+255 min) time during which the compressor is off in case of faulty thermostat probe. With COF=0 compressor is always active.
- CH1 Kind of action for section 1:** CL = cooling; Ht = heating

### REGULATION – SECTION 2

- LS2 Minimum set point2 limit:** (-50,0°C+SET2; -58°F+SET2) Sets the minimum acceptable value for the set point2.
- US2 Maximum set point2 limit:** (SET2+110°C; SET2+230°F) Set the maximum acceptable value for set point2.
- OdS2 Outputs activation delay of section 2 at start up:** (0+255 min) This function is enabled at the initial start up of the instrument and inhibits any output activation of the section 1 for the period of time set in the parameter.
- AC2 Anti-short cycle delay for compressor2:** (0+30 min) interval between the compressor2 stop and the following restart.
- Con2 Compressor2 ON time with faulty probe2:** (0+255 min) time during which the compressor2 is active in case of faulty thermostat probe. With CO<sub>n</sub>=0 compressor2 is always OFF.
- COF2 Compressor2 OFF time with faulty probe2:** (0+255 min) time during which the compressor is off in case of faulty thermostat probe. With COF=0 compressor2 is always active.
- CH2 Kind of action for section 2:** CL = cooling; Ht = heating

### DISPLAY

- CF Temperature measurement unit:** °C = Celsius; °F = Fahrenheit. When the measurement unit is changed the SET point and the values of some parameters have to be modified.
- rES Resolution (for °C):** (in = 1°C; de = 0,1°C) allows decimal point display. **dE** = 0,1°C; **in** = 1 °C
- Lod1 Bottom display visualization:** select which probe is displayed by the instrument in the bottom display: **P1** = Thermostat1 probe; **P2** = Evaporator probe; **P2** = Thermostat2 probe
- Lod2 Upper display visualization:** select which probe is displayed by the instrument in the upper display: **P1** = Thermostat1 probe; **P2** = Evaporator probe; **P2** = Thermostat2 probe

### DEFROST

- dFS relation between defrosts:** 4 relation between the 2 sections of the controller are available, to manage different kinds of applications: **in** = independent defrosts; **StS** = same defrost start, synchronised defrost end; **St** = same defrost start, independent defrost end; **SE** = sequential defrost;
- tdF1 Defrost type, section 1:** **rE** = electrical heater (Compressor OFF); **in** = hot gas (Compressor and defrost relays ON)

- EdF1 Defrost mode, section 1:** in = interval mode. The defrost starts when the time "IdF1" is expired. **Sd = Smartdefrost mode.** The time IdF (interval between defrosts) is increased only when the compressor is running (even non consecutively).
- SdF1 Set point for SMARTDEFROST, section 1:** (-30:+30 °C/ -22:+86 °F) evaporator temperature which allows the IdF counting (interval between defrosts) in SMARTDEFROST mode.
- dtE1 Defrost termination temperature, section 1:** (-50,0+110,0°C; -58+230°F) (Enabled only when the evaporator probe is present) sets the temperature measured by the evaporator probe which causes the end of defrost.
- IdF1 Interval between defrosts, section 1:** (1+120h) Determines the time interval between the beginning of two defrost cycles.
- MdF1 (Maximum) duration of defrost, section 1:** (0+255 min) When **P2P = no**, no evaporator probe, it sets the defrost duration, when **P2P = yES**, defrost end based on temperature, it sets the maximum length for defrost.
- tPF1 Pre-defrost time:** (0+30min) The compressor is activated for this time before a hot gas defrost.
- Fdt1 Drain down time, section 1:** (0+60 min.) time interval between reaching defrost termination temperature and the restoring of the control's normal operation. This time allows the evaporator to eliminate water drops that might have formed due to defrost.
- dPo1 First defrost after start-up, section 1:** y = Immediately; n = after the IdF time
- EdF2 Defrost mode, section 2:** in = interval mode. The defrost starts when the time "IdF2" is expired. **Sd = Smartdefrost mode.** The time IdF (interval between defrosts) is increased only when the compressor is running (even non consecutively).
- IdF2 Interval between defrosts, section 2:** (1+120h) Determines the time interval between the beginning of two defrost cycles.
- MdF2 (Maximum) duration of defrost, section 2:** (0+255 min) it sets the defrost duration.
- dFd Display during defrost:** rt = real temperature; it = temperature reading at the defrost start; **Set** = set point; **dEF** = "dEF" label; **dEG** = "dEG" label;
- dAd Defrost display time out:** (0+255 min) Sets the maximum time between the end of defrost and the restarting of the real room temperature display.
- dSd Start defrost delay :** ( 0+99min) This is useful when different defrost start times are necessary to avoid overloading the plant.

**FANS**

- FnC1 Fan operating mode, section 1:** **C-n** = running with the compressor1, OFF during the defrost; **C-y** = running with the compressor1, ON during the defrost; **O-n** = continuous mode, OFF during the defrost; **O-y** = continuous mode, ON during the defrost;
- Fnd1 Fan delay after defrost, section 1:** (0+255 min) The time interval between the defrost end and evaporator fans start.
- FSt1 Fan stop temperature, section 1:** (-50+110°C; -58+230°F) setting of temperature, detected by evaporator probe, above which the fan is always OFF.
- FAP1 Probe selection for fans management, section 1:** **nP** = no probe: fan follows the setting of FnC1 parameter; **P1** = thermostat 1 probe; **P2** = thermostat 2 probe; **P3** = evaporator probe;

**ALARMS**

- ALc1 Temperature alarms configuration, section 1:** it determines if alarms are relative to set point 1 or referred to absolute values: **rE** relative to set point; **Ab** absolute temperature
- ALU1 Maximum alarm, section 1:**  
  - with ALc1=rE:** alarm relative to set point1, (0+50°C) Maximum alarm is enabled when the probe values exceeds the "SET1+ALU" value.
  - with ALc1=Ab:** absolute alarm, (Set1+Full Sc.) Maximum alarm is enabled when the probe values exceeds the "ALU" value.
- ALL1 Minimum alarm, section 1:**  
  - with ALc1=rE:** relative to set point1, (0+50°C) this value is subtracted from the set point1. The alarm signal is enabled when the probe values goes below the "SET1-ALL" value.
  - with ALc1=Ab** absolute value, minimum alarm is enabled when the probe values goes below the "ALL1" value.
- ALd1 Temperature alarm delay, section 1:** (0+255 min) time interval between the detection of an alarm condition and the corresponding alarm signalling.
- dAo1 Delay of temperature alarm at start-up, section 1:** (0min+23h 50min) time interval between the detection of the temperature alarm condition in section after the instrument power on and the alarm signalling.
- ALc2 Temperature alarms configuration, section 2:** it determines if alarms are relative to set point 2 or referred to absolute values: **rE** relative to set point; **Ab** absolute temperature
- ALU2 Maximum alarm, section 2:**  
  - with ALc2=rE:** alarm relative to set point1, (0+50°C) Maximum alarm is enabled when the probe values exceeds the "SET2+ALU" value.
  - with ALc2=Ab:** absolute alarm, (Set2+Full Sc.) Maximum alarm is enabled when the probe values exceeds the "ALU" value.
- ALL2 Minimum alarm, section 2:**  
  - with ALc2=rE:** relative to set point1, (0+50°C) this value is subtracted from the set point2. The alarm signal is enabled when the probe values goes below the "SET2-ALL" value.
  - with ALc2=Ab** absolute value, minimum alarm is enabled when the probe values goes below the "ALL2" value.
- ALd2 Temperature alarm delay, section 2:** (0+255 min) time interval between the detection of an alarm condition and the corresponding alarm signalling.
- dAo2 Delay of temperature alarm at start-up, section 2:** (0min+23h 50min) time interval between the detection of the temperature alarm condition in section after the instrument power on and the alarm signalling.
- AFH Temperature alarm and fan differential:** (0,1+25,5°C; 1+45°F) Intervention differential for temperature alarm set point and fan regulation set point, always positive.
- EdA Alarm delay at the end of defrost:** (0+255 min) Time interval between the detection of the temperature alarm condition at the end of defrost and the alarm signalling.



- dot** Delay of temperature alarm after closing the door : (0÷255 min) Time delay to signal the temperature alarm condition after closing the door.
- doA** Open door alarm delay:(0÷255 min) delay between the detection of the open door condition and its alarm signalling: the flashing message "dA" is displayed.

**PROBE INPUTS**

- Pbc** Kind of probe: Ptc = PTC; ntc = NTC
- oFS1** Thermostat1 probe calibration: (-12.0÷12.0°C / -21÷21°F) allows to adjust possible offset of the thermostat1 probe.
- oFS2** Thermostat2 probe calibration: (-12.0÷12.0°C / -21÷21°F) allows to adjust possible offset of the thermostat2 probe.
- oFS3** Evaporator probe calibration: (-12.0÷12.0°C / -21÷21°F) allows to adjust possible offsets of the evaporator probe.
- P2P** Thermostat2 probe presence : no= not present; yES= present.
- P3P** Evaporator probe presence : no= not present: the defrost stops only by time; yES= present: the defrost stops by temperature and time.

**DIGITAL INPUTS**

- i1P** Digital input 1 polarity (14-15):  
 CL : the digital input is activated by closing the contact;  
 OP : the digital input is activated by opening the contact.
- i1F** Digital input 1 operating mode(14-15): configure the digital input function:  
 MP1 = door switch 1; MP2 = door switch 2, MP: door switch (it's used by both the sections); EA1 = generic alarm section 1; EA2 = generic alarm section 2; EAL = generic alarm (it's used by both the sections); bA1 = serious alarm mode section 1; bA2 = serious alarm mode section 2; , bAL = serious alarm mode section (it's used by both the sections); dF1 = Start defrost, section 1; dF2 = Start defrost, section 2; dEF = Start defrost (it's used by both the sections); oF1 = remote on/ off, section1; oF2 = remote on/ off, section 2; oFF = = remote on/ off (it's used by both the sections); ES = Energy Saving
- i2P** Digital input 2 polarity(13-14):  
 CL : the digital input is activated by closing the contact;  
 OP : the digital input is activated by opening the contact.
- i2F** Digital input 2 operating mode(13-14): configure the digital input function:  
 MP1 = door switch 1; MP2 = door switch 2, MP: door switch (it's used by both the sections); EA1 = generic alarm section 1; EA2 = generic alarm section 2; EAL = generic alarm (it's used by both the sections); bA1 = serious alarm mode section 1; bA2 = serious alarm mode section 2; , bAL = serious alarm mode section (it's used by both the sections); dF1 = Start defrost, section 1; dF2 = Start defrost, section 2; dEF = Start defrost (it's used by both the sections); oF1 = remote on/ off, section1; oF2 = remote on/ off, section 2; oFF = = remote on/ off (it's used by both the sections); ES = Energy Saving
- odc1** Compressor and fan status when open door, section 1: no = normal; Fan = Fan OFF; CPr = Compressor OFF; F\_C = Compressor and fan OFF;
- rrd1=** Outputs restart after door open alarm, section 1: n = status of outputs according to odc1; Y= outputs restart working.
- did1** Time interval delay for digital input alarm, section 1:(0÷255 min.) With i1F or i2F = EAL1 or bAL1 (external alarms), "did" parameter defines the time delay between the detection and the successive signalling of the alarm.
- odc2** Compressor status when open door, section 2: no ,Fan = normal; CPr, F\_C = Compressor OFF.
- rrd2** Outputs restart after door open alarm, section 2: n = status of outputs according to odc2; Y= outputs restart working.
- did2** Time interval delay for digital input alarm, section 2:(0÷255 min.) With i1F or i2F = EAL1 or bAL1 (external alarms), "did" parameter defines the time delay between the detection and the successive signalling of the alarm.

**OTHER**

- oA6** Auxiliary output configuration: (cP1 / cP2 / dF1 / dF2 / Fn1 / Fn2 / Lg1 / Lg2 / on1 / on2 / db1 / db2 / ALr) cP1= compressor 1, cP2= compressor 2; dF1= defrost 1; dF2= defrost 2; Fn1= fans 1; Fn2= fans 2; Lg1= light 1; Lg2= light 2; on1= On/Off; on2= On/Off; db1= n.u.; db2= n.u.; ALr= alarm.
- tbA** Alarm relay silencing: y= relay silencing with alarm; n= silencing only alarm signals
- AoP** Alarm relay polarity: cL= active closed; oP= active opened
- HES1** Temperature increase during the Energy Saving cycle, section 1: (-30÷30°C / -54÷54°F) sets the increasing value of the set point1 during the Energy Saving cycle.
- HES2** Temperature increase during the Energy Saving cycle, section 2: (-30÷30°C / -54÷54°F) sets the increasing value of the set point2 during the Energy Saving cycle.

**TO SET CURRENT TIME AND WEEKLY HOLIDAYS (ONLY WITH RTC)**

- Hur** Current hour (0 ÷ 23 h)
- Min** Current minute (0 ÷ 59min)
- dAY** Current day (Sun ÷ Sat)
- Hd1** First weekly holiday (Sun ÷ nu) Set the first day of the week which follows the holiday times.
- Hd2** Second weekly holiday (Sun ÷ nu) Set the second day of the week which follows the holiday times.
- Hd3** Third weekly holiday (Sun ÷ nu) Set the third day of the week which follows the holiday times.

N.B. Hd1,Hd2,Hd3 can be set also as "nu" value (Not Used).

**TO SET ENERGY SAVING TIMES (ONLY WITH RTC)**

- ILE** Energy Saving cycle start during workdays: (0 ÷ 23h 50 min.) During the Energy Saving cycle the set point is increased by the value in HES so that the operation set point is SET + HES.
- dLE** Energy Saving cycle length during workdays: (0 ÷ 24h 00 min.) Sets the duration of the Energy Saving cycle on workdays.

ISE Energy Saving cycle start on holidays. (0 ÷ 23h 50 min.)

dSE Energy Saving cycle length on holidays (0 ÷ 24h 00 min.)

#### TO SET DEFROST TIMES (ONLY WITH RTC)

**L1d1+L1d6 Workday defrost start SECTION 1 (0 ÷ 23h 50 min.)** These parameters set the beginning of the eight programmable defrost cycles during workdays. Ex. When L1d2 = 12.4 the second defrost starts at 12.40 during workdays.

**S1d1+S1d6 Holiday defrost start (0 ÷ 23h 50 min.)** These parameters set the beginning of the eight programmable defrost cycles on holidays. Ex. When S1d2 = 3.4 the second defrost starts at 3.40 on holidays.

**L2d1+L2d6 Workday defrost start SECTION 2 (0 ÷ 23h 50 min.)** These parameters set the beginning of the eight programmable defrost cycles during workdays. Ex. When L2d2 = 12.4 the second defrost starts at 12.40 during workdays.

**S2d1+S2d6 Holiday defrost start (0 ÷ 23h 50 min.)** These parameters set the beginning of the eight programmable defrost cycles on holidays. Ex. When S2d2 = 3.4 the second defrost starts at 3.40 on holidays.

**N.B. :** To disable a defrost cycle set it to "nu"(not used).

Ex. If L1d6=nu ; the sixth defrost cycle is disabled

#### UTILITY

**Adr1 RS485 serial address, section 1 (1÷247):** Identifies section 1 address when connected to a ModBUS compatible monitoring system.

**Adr2 RS485 serial address, section 2 (1÷247):** Identifies section 2 address when connected to a ModBUS compatible monitoring system.

If Adr1 = Adr2

**dP1 First probe display**

**dP2 Second probe display**

**dP3 Third probe display**

**rEL Release software:** (read only) Software version of the microprocessor.

**Ptb Parameter table:** (read only) it shows the original code of the **dixell** parameter map.

**Pr2 Access to the protected parameter list** (read only).

## 8. DIGITAL INPUT

The instrument can support up to 2 free contact digital inputs. Both of them can be configured as One is always configured as door switch, the second is programmable in seven different configurations by the "1ZF" parameter.

### 1.14 DOOR SWITCH INPUT (MP1, MP2, MP)

It signals the door status to the controller: **MP1:** door open for section 1; **MP2:** door open for section 2; **MP** door open for both the sections.

When the door is open the status of compressor (and fans) depends on the "odc1" and "odc2" parameters: **no** = normal (no changes); **Fan** = Fan OFF (if fan is present); **CP**r = Compressor OFF; **F\_C** = Compressor and fan OFF. Since the door is opened, after the delay time set through parameter "doA", the alarm output is enabled and the display shows the message "dA". The alarm stops as soon as the external digital input is disabled again. During this time and then for the delay "dot" after closing the door, the high and low temperature alarms are disabled.

### 1.15 CONFIGURABLE INPUT - GENERIC ALARM (EA1, EA2, EAL)

It signals to the controller: **EA1:** generic alarm – section 1; **EA2:** generic alarm – section 2; **EAL:** generic alarm – it counts for both the sections.

As soon as the digital input is activated the unit will wait for "did1" time for section 1 and "did2" time for section 2 delay before signalling the "EAL" alarm message. The outputs status don't change. The alarm stops just after the digital input is de-activated.

### 1.16 CONFIGURABLE INPUT - SERIOUS ALARM MODE (BA1, BA2, BAL)

It signals to the controller: **BA1:** serious alarm – section 1; **BA2:** serious alarm – section 2; **BAL:** serious alarm – it counts for both the sections.

As soon as the digital input is activated the unit will wait for "did1" time for section 1 and "did2" time for section 2 delay before signalling the "bAL" alarm message. The relay outputs are switched OFF. The alarm will stop as soon as the digital input is de-activated.

### 1.17 CONFIGURABLE INPUT - START DEFROST (DF1, DF2, DEF)

It executes a defrost if there are the right conditions, respectively for: **df1:** section 1; **df2:** section 2; **dEF:** both the sections.

After the defrost is finished, the normal regulation will restart only if the digital input is disabled otherwise the instrument will wait until the "MdF1" and "MdF2" safety time is expired.

### 1.18 CONFIGURABLE INPUT - REMOTE ON/OFF (OF1, OF2, ONF)

This function allows to switch ON and OFF a sections of the instrument or the whole instrument according to the following setting: **of1:** section 1; **of2:** section 2; **onF:** it counts for both the sections. When the digital input is de-activated, the corresponding section restarts working.

### 1.19 CONFIGURABLE INPUT - ENERGY SAVING (ES)

The Energy Saving function allows to change the set point value as the result of the SET1+HES1 for section and SET2 + HES2 fro section 2. This function is enabled until the digital input is activated.

### 1.20 DIGITAL INPUTS POLARITY

The digital inputs polarity depends on "11P" and "12P" parameters: **CL** : the digital input is activated by closing the contact; **OP** : the digital input is activated by opening the contact

9. INSTALLATION AND MOUNTING

The temperature range allowed for correct operation is 0 - 60 °C. Avoid places subject to strong vibrations, corrosive gases, excessive dirt or humidity. The same recommendations apply to probes. Let the air circulate by the cooling holes. Thanks to the case, XLH260 model can be panel or wall mounted. See the following instructions for details.

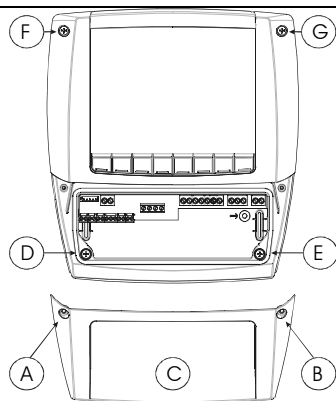

FIG. 1

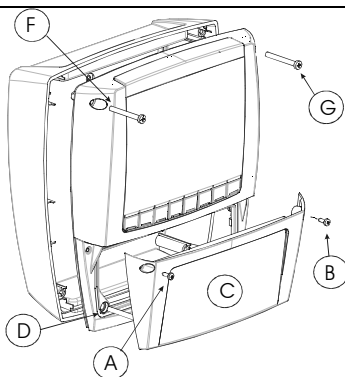

FIG. 2

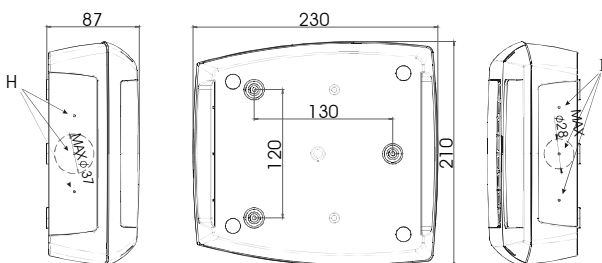

FIG. 3

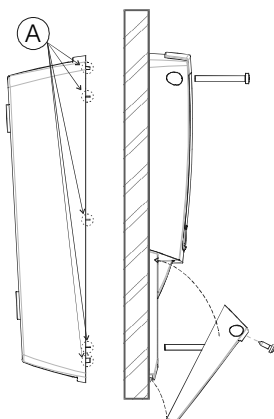

Fig. 6

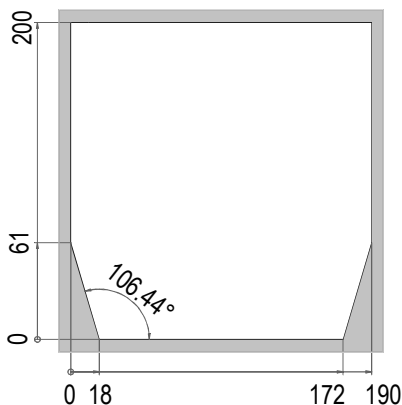

Fig. 4

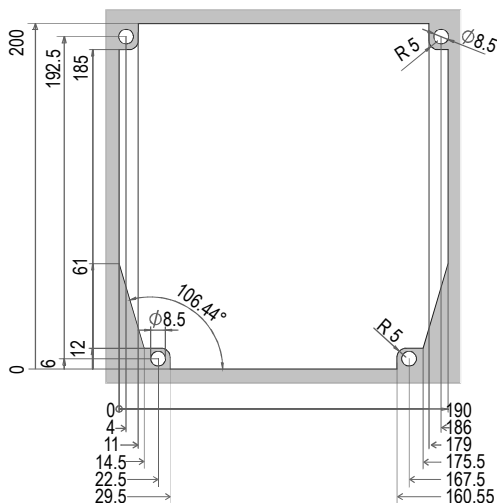

Fig. 5

### 1.21 WALL MOUNTING

1. Unscrew the 4 frontal screws (Fig. 1, A, B, F, G) and remove the cover (Fig. 1, C).
2. Unscrew the 2 screws (Fig. 1, D, E) that keep connected the frontal and lower parts of Cool Mate and separate the 2 parts.
3. Make the proper holes for cablepresses or pipepresses using the centres signed in the bottom cover of the Cool Mate, (Fig. 3, H, I, ). Then make 3 holes in the wall, as indicated in (Fig. 3, L, M, N), to fix the Cool Mate
4. Fix the cablepresses and the pipepresses..
5. Insert the wall-nugs, contained in the kit, into the holes made in the wall. Then use the o-rings and fix the back part of the Cool Mate (Fig. 3, L, M, N) by means of the 3 screws to the wall itself.
6. Insert the wiring cables in cablepresses or in the pipepresses.
7. Mount the frontal part using the previous 4 screws Fig. 1, D, E, F, G. (do not press excessively in order to avoid plastic deformation).
8. After connecting the wires to the terminal blocks close the cover (Fig. 2, c) and fix it by the screws.

### 1.22 PANEL MOUNTING

1. Make a hole in the panel with dimensions described in Fig. 4 (simplified) or Fig. 5 (completed)
2. Unscrew the 4 frontal screws (Fig. 1, A, B, F, G) and remove the cover (Fig. 1, C).
3. Unscrew the 2 screws (Fig. 1, D, E) that keep connected the frontal and lower parts of Cool Mate and separate the 2 parts.
4. Cut from the back part of the Cool Mate the teeth indicated in Fig. 6, A.
5. Make the proper holes for cablepresses or pipepresses using the centres signed in the bottom cover of the Cool Mate, (Fig. 3, H, I, ).
6. Fix the cablepresses and the pipepresses..
7. Insert the wiring cables in cablepresses or in the pipepresses.
8. Join the back and frontal parts, with the panel in the middle, and fix them screwing the 4 screws taken previously away (dimensions 4x35 mm), in the holes of Fig. 1, A, B, D, E. Maximum panel thickness: 6mm.
9. After connecting the wires to the terminal blocks close the cover (Fig. 2, c) and fix it by the screws.

## 10. DIMENSIONS

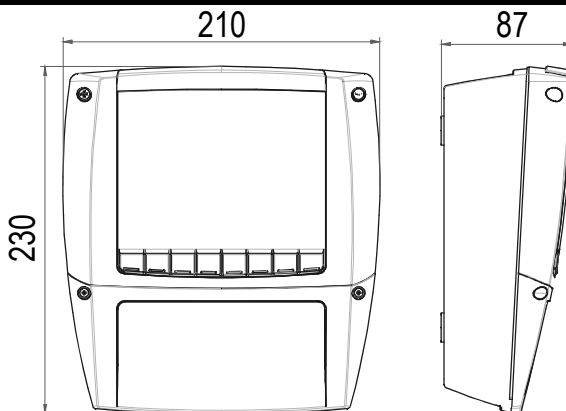

## 11. ELECTRICAL CONNECTIONS

The instruments are provided with screw terminal block to connect cables with a cross section up to 2,5 mm<sup>2</sup>. Heat-resistant cables have to be used. Before connecting cables make sure the power supply complies with the instrument's requirements. Separate the probe cables from the power supply cables, from the outputs and the power connections. Do not exceed the maximum current allowed on each relay, in case of heavier loads use a suitable external relay.

### 1.23 PROBE CONNECTIONS

The probes shall be mounted with the bulb upwards to prevent damages due to casual liquid infiltration. It is recommended to place the thermostat probe away from air streams to correctly measure the average room temperature.

## 12. HOW TO USE THE HOT KEY

### 1.24 HOW TO PROGRAM A HOT KEY FROM THE INSTRUMENT (UPLOAD)

1. Program one controller with the front keypad.
2. When the controller is ON, insert the "Hot key" and push  $\blacktriangle$  key; the "uPL" message appears followed a by flashing "End"
3. Push "SET" key and the End will stop flashing.
4. Turn OFF the instrument remove the "Hot Key", then turn it ON again.

**NOTE:** the "Err" message is displayed for failed programming. In this case push again  $\blacktriangle$  key if you want to restart the upload again or remove the "Hot key" to abort the operation.

### 1.25 HOW TO PROGRAM AN INSTRUMENT USING A HOT KEY (DOWNLOAD)

1. Turn OFF the instrument.
2. Insert a **programmed "Hot Key"** into the 5 PIN receptacle and then turn the Controller ON.
3. Automatically the parameter list of the "Hot Key" is downloaded into the Controller memory, the "doL" message is blinking followed a by flashing "End".
4. After 10 seconds the instrument will restart working with the new parameters.
5. Remove the "Hot Key"..

**NOTE** the message "Err" is displayed for failed programming. In this case turn the unit off and then on if you want to restart the download again or remove the "Hot key" to abort the operation.

## 13. ALARM SIGNALS

Message	Cause	Outputs
"P1"	Thermostat1 probe failure	Alarm output ON; Compressor1 output according to parameters "CO1" and "COF1"
"P2"	Thermostat2 probe failure	Alarm output ON; Compressor2 output according to parameters "CO2" and "COF2"
"P3"	Evaporator probe failure	Alarm output ON; Other outputs unchanged
"HA"	High temperature alarm	Outputs unchanged
"LA"	Low temperature alarm	Outputs unchanged
"EE"	Some memory problems	Alarm output ON; Other outputs OFF
"dA"	Door switch alarm	Outputs unchanged

"EAL"	External alarm	Outputs unchanged
"bAL"	Serious external alarm	Regulation outputs deactivated
"POF"	Keyboard locked	Outputs unchanged
"POn"	Keyboard unlocked	Outputs unchanged

The alarm message is displayed until the alarm condition is recovery.

All the alarm messages are showed alternating with the room temperature except for the "P1" which is flashing. To reset the "EE" alarm and restart the normal functioning press any key, the "rSt" message is displayed for about 3s.

**1.26 SILENCING BUZZER**

Once the alarm signal is detected the buzzer can be silenced by pressing any key.

**1.27 "EE" ALARM**

The **dixell** instruments are provided with an internal check for the data integrity. Alarm "EE" flashes when a failure in the memory data occurs. In such cases the alarm output is enabled.

**1.28 ALARM RECOVERY**

Probe alarms : "P1" (probe1 faulty), "P2" and "P3"; they automatically stop 10s after the probe restarts normal operation. Check connections before replacing the probe. Door switch alarm "dA" stop as soon as the door is closed. External alarms "EAL", "bAL" stop as soon as the external digital input is disabled. The alarm message is displayed until the alarm condition is recovery. All the alarm messages are showed alternating with the room temperature except for the "P1" which is flashing.

**14. TECHNICAL DATA**

**Housing:** self extinguishing ABS; **Case:** frontal 210x230 mm; depth 87mm; **Mounting:** See par. 9; **Protection:** IP65

**Connections:** Screw terminal block ≤ 2,5 mm<sup>2</sup> wiring.

**Power supply:** 230Vac 50/60Hz ± 10% or 110Vac 50/60Hz ± 10%; **Power absorption:** 10VA max.

**Display:** 3 digits, red LED, 30.5 mm high; 3 digits, yellow LED low.

**Inputs:** 3 NTC or PTC Probes

**Digital inputs :** door switch and configurable, free voltage. Max. distance 10m

**Relay outputs:**

**Compressor 1:** relay SPST 20(8) A, 250Vac;

**Compressor 2:** relay SPST 20(8) A, 250Vac;

**defrost:** relay SPDT 16(3) A, 250Vac;

**light:** relay SPDT 16 A, 250Vac;

**fans:** relay SPST 8(3) A, 250Vac;

**alarm:** relay SPST 8(3) A, 250Vac;

**Other output:** Direct RS485 (optional)

**Data storing:** on the non-volatile memory (EEPROM).

**Kind of action:** 1B.; **Pollution grade:** normal; **Software class:** A.

**Operating temperature:** 0+60 °C.; **Storage temperature:** -25+60 °C.

**Relative humidity:** 20-85% (no condensing)

**Measuring and regulation range:** **NTC probe:** -40+110°C (-58+230°F);

**Resolution:** 0,1 °C or 1°C or 1 °F (selectable).

**Accuracy:** (ambient temp. 25°C): ±0,5 °C ±1 digit

**15. WIRING CONNECTIONS**

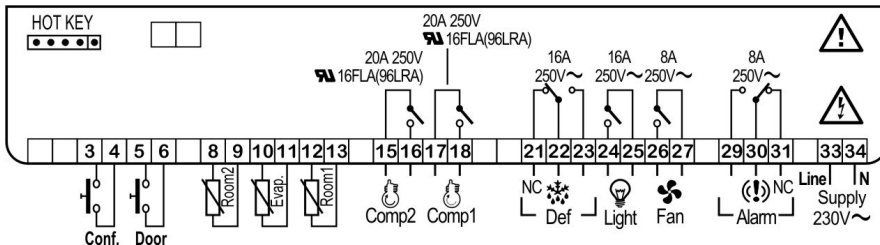

**16. DEFAULT SETTING VALUES**

Label	Name	Range	Default	level
<b>REGULATION</b>				
Set1	Set point 1	LS1+US1	-5	Pr1
Set2	Set point 2	LS2+US2	3	Pr1

Label	Name	Range	Default	level
Hy1	Differential 1	0,1+25,5 °C / 1+45°F	2.0	Pr1
Hy2	Differential 2	0,1+25,5 °C / 1+45°F	2.0	Pr1
<b>REGULATION – SECTION 1</b>				
LS1	Minimum set point1 limit	-50,0°C+SET1 / -58°F+SET1	-50.0	Pr2
US1	Maximum set point1 limit	SET1 + 150°C / SET1 + 302°F	110	Pr2
odS1	Outputs activation delay of sect. 1 at start up	0+255 min.	0	Pr2
Ac1	Anti-short cycle delay for compressor1	0+30 min.	1	Pr1
con1	Compressor1 ON time with faulty probe1	0+255 min.	15	Pr2
coF1	Compressor1 OFF time with faulty probe1	0+255 min.	15	Pr2
ch1	Kind of action for section 1	cL / Ht	cL	Pr2
<b>REGULATION – SECTION 2</b>				
LS2	Minimum set point2 limit	-50,0°C+SET2 / -58°F+SET2	-50.0	Pr2
US2	Maximum set point2 limit	SET2 + 150°C / SET2 + 302°F	110	Pr2
odS2	Outputs activation delay of sect. 2 at start up	0+255 min.	0	Pr2
Ac2	Anti-short cycle delay for compressor2	0+30 min.	1	Pr1
con2	Compressor2 ON time with faulty probe2	0+255 min.	15	Pr2
coF2	Compressor2 OFF time with faulty probe2	0+255 min.	15	Pr2
ch2	Kind of action for section 2	cL / Ht	cL	Pr2
<b>DISPLAY</b>				
cF	Temperature measurement unit	°C / °F	°C	Pr2
rES	Resolution (for °C)	in + de	dE	Pr1
Lod1	Bottom display visualization	P1 + P4	P1	Pr2
Lod2	Upper display visualization	P1 + P4	P3	Pr2
<b>DEFROST</b>				
dFS	Relation between defrosts	ind; SIS; Sti; SE	ind	Pr2
tdF1	Kind of defrost section 1	rE, in	rE	Pr2
EdF1	Defrost mode, section 1	In, Sd, RTC	in	Pr2
SdF1	Set point for Smart Defrost section 1	-30 + +30°C / -22++86°F	0	Pr2
dtE1	End defrost temperature section 1	-50,0+110°C/ -58+230°F	6.0	Pr2
idF1	Interval between defrosts, section 1	1+120ore	6	Pr1
MdF1	Maximum duration of defrost, section 1	0+255 min.	20	Pr1
tPF1	Pre-defrost compressor on time	0+30 min.	0	Pr2
Fdt1	Dripping time section 1. 1	0+60 min.	0	Pr2
dPo1	Defrost at power on section . 1	n + y	n	Pr2
EdF2	Defrost mode, section 2:	In, Sd, RTC	in	Pr2
idF2	Interval between defrosts, section 2	1+120ore	8	Pr1
MdF2	(Maximum) duration of defrost, section 2	0+255 min.	20	Pr1
dFd	Display during defrost	rt, it, SEt, dEF, dEG	it	Pr2
dAd	Defrost display time out	0+255 min.	20	Pr2
dSd	Defrost delay	0+255 min.	0	Pr2
<b>FANS</b>				
FnC1	Fans operating mode, section 1	C-n, C-y, O-n, O-y	O-n	Pr2
Fnd1	Fans delay after defrost, section 1	0+255 min.	10	Pr2
FSt1	Fans stop temperature, section 1	-50,0+110°C/ -58+230°F	2.0	Pr2
FAP1	Probe for fans	P1+P3	P2	Pr2
<b>ALARM</b>				
ALc1	Temperature alarms configuration, section 1	rE / Ab	Ab	Pr2
ALu1	Maximum alarm, section 1	-50,0+150°C/ -58+302°F	110	Pr1
ALL1	Minimum alarm, section 1	-50,0+150°C/ -58+302°F	-50.0	Pr1
ALd1	Temperature alarm delay, section 1	0+255 min.	15	Pr2
dAo1	Delay of temp. alarm at start-up, section 1	0 + 23h 50 min.	1.3	Pr2
ALc2	Temp. alarms configuration, section 2	re + Ab	Ab	Pr2
ALu2	Maximum alarm, section 2	-50,0+150°C/ -58+302°F	110	Pr1
ALL2	Minimum alarm, section 2	-50,0+150°C/ -58+302°F	-50.0	Pr1
ALd2	Temperature alarm delay, section 2	0+255 min.	15	Pr2
dAo2	Delay of temp. alarm at start-up, section 2	0 + 23h 50 min.	1.3	Pr2
AFH	Temperature alarm and fan differential	0,1+25,5 °C / 1+45°F	1.0	Pr2

Label	Name	Range	Default	level
EdA	Alarm delay at the end of defrost	0+255 min.	20	Pr2
dot	Delay of temp. alarm after closing the door	0+255 min.	20	Pr2
doA	Open door alarm delay	0+254 min., nu	15	Pr2
Pbc	Kind of probe	PTC/ntc	ntc	Pr2
<b>ANALOGUE INPUTS</b>				
oFS1	Thermostat1 probe calibration	-12,0+12,0°C / -21+21°F	0.0	Pr2
oFS2	Thermostat2 probe calibration	-12,0+12,0°C / -21+21°F	0.0	Pr2
oFS3	Evaporator probe calibration	-12,0+12,0°C / -21+21°F	0.0	Pr2
P2P	Thermostat2 probe presence	n / y	Y	Pr2
P3P	Evaporator probe presence	n + y	Y	Pr2
<b>DIGITAL INPUTS</b>				
i1P	Digital input 1 polarity	cL+OP	cL	Pr2
i1F	Digital input 1 operating mode	MP1; MP2, MP; EA1; EA2; EAL; bA1; bA2; , bAL; dF1; dF2; dEF; oF1; oF2; oFF; ES	EAL	Pr2
i2P	Digital input 2 polarity	cL+OP	cL	Pr2
i2F	Digital input 2 operating mode	MP1; MP2, MP; EA1; EA2; EAL; bA1; bA2; , bAL; dF1; dF2; dEF; oF1; oF2; oFF; ES	EAL	Pr2
odc1	Comp. and fan status when open door, sect 1	no, Fan, CPr, F_C	no	Pr2
rrd1	Outputs restart after door open alarm, sect. 1	n, y	Y	Pr2
did1	Time interval delay for digital input alarm, sect. 1	0+255 min.	5	Pr2
odc2	Comp. status when open door, section 2:	no, Fan, CPr, F_C	no	Pr2
rrd2	Outputs restart after door open alarm, sect. 2	n, y	Y	Pr2
did2	Time interval delay for digital input alarm, sect. 2	0+255 min.	5	Pr2
<b>OTHER</b>				
oa6	Auxiliary output configuration	cP1 / cP2 / dF1 / dF2 / Fn1 / Fn2 / Lg1 / Lg2 / on1 / on2 / db1 / db2 / ALr	Alr	Pr2
tbA	Alarm relay silencing	n - Y	Y	Pr2
AoP	Alarm relay polarity	cL - oP	cL	Pr2
HES1	Temp. increase during the Energy Saving cycle, sect. 1	-30+30°C / -54+54°F	0	Pr2
HES2	Temp. increase during the Energy Saving cycle, section 2	-30+30°C / -54+54°F	0	Pr2
<b>TIME AND WEEKLY HOLIDAYS (ONLY WITH RTC)</b>				
Hur	Current hour	0 ÷ 23	0	Pr2
Min	Current minute	0 ÷ 59	0	Pr2
dAY	Current day	Sun ÷ SAT	Sun	Pr2
Hd1	First weekly holiday	Sun ÷ SAT - nu	nu	Pr2
Hd2	Second weekly holiday	Sun ÷ SAT - nu	nu	Pr2
Hd3	Third weekly holiday	Sun ÷ SAT - nu	nu	Pr2
<b>ENERGY SAVING TIMES (ONLY WITH RTC)</b>				
ILE	Energy Saving cycle start during workdays	0 ÷ 23h 50 min.	0	Pr2
dLE	Energy Saving cycle length during workdays	0 ÷ 24h 00 min.	0	Pr2
ISE	Energy Saving cycle start on holidays	0 ÷ 23h 50 min.	0	Pr2
dSE	Energy Saving cycle length on holidays	0 ÷ 24h 00 min.	0	Pr2
<b>DEFROST TIMES (ONLY WITH RTC)</b>				
L1d1	1 <sup>st</sup> workdays defrost start (Section 1)	0 ÷ 23h 50 min. - nu	6.0	Pr2
L1d2	2 <sup>nd</sup> workdays defrost start (Section 1)	0 ÷ 23h 50 min. - nu	13.0	Pr2
L1d3	3 <sup>rd</sup> workdays defrost start (Section 1)	0 ÷ 23h 50 min. - nu	21.0	Pr2
L1d4	4 <sup>th</sup> workdays defrost start (Section 1)	0 ÷ 23h 50 min. - nu	nu	Pr2
L1d5	5 <sup>th</sup> workdays defrost start (Section 1)	0 ÷ 23h 50 min. - nu	nu	Pr2
L1d6	6 <sup>th</sup> workdays defrost start (Section 1)	0 ÷ 23h 50 min. - nu	nu	Pr2
S1d1	1 <sup>st</sup> holiday defrost start (Section 1)	0 ÷ 23h 50 min. - nu	6.0	Pr2
S1d2	2 <sup>nd</sup> holiday defrost start (Section 1)	0 ÷ 23h 50 min. - nu	13.0	Pr2
S1d3	3 <sup>rd</sup> holiday defrost start (Section 1)	0 ÷ 23h 50 min. - nu	21.0	Pr2
S1d4	4 <sup>th</sup> holiday defrost start (Section 1)	0 ÷ 23h 50 min. - nu	nu	Pr2
S1d5	5 <sup>th</sup> holiday defrost start (Section 1)	0 ÷ 23h 50 min. - nu	nu	Pr2
S1d6	6 <sup>th</sup> holiday defrost start (Section 1)	0 ÷ 23h 50 min. - nu	nu	Pr2
L2d1	1 <sup>st</sup> workdays defrost start (Section 2)	0 ÷ 23h 50 min. - nu	6.0	Pr2
L2d2	2 <sup>nd</sup> workdays defrost start (Section 2)	0 ÷ 23h 50 min. - nu	13.0	Pr2
L2d3	3 <sup>rd</sup> workdays defrost start (Section 2)	0 ÷ 23h 50 min. - nu	21.0	Pr2



Label	Name	Range	Default	level
L2d4	4 <sup>th</sup> workdays defrost start (Section 2)	0 + 23h 50 min. - nu	nu	Pr2
L2d5	5 <sup>th</sup> workdays defrost start (Section 2)	0 + 23h 50 min. - nu	nu	Pr2
L2d6	6 <sup>th</sup> workdays defrost start (Section 2)	0 + 23h 50 min. - nu	nu	Pr2
S2d1	1 <sup>st</sup> holiday defrost start (Section 2)	0 + 23h 50 min. - nu	6.0	Pr2
S2d2	2 <sup>nd</sup> holiday defrost start (Section 2)	0 + 23h 50 min. - nu	13.0	Pr2
S2d3	3 <sup>rd</sup> holiday defrost start (Section 2)	0 + 23h 50 min. - nu	21.0	Pr2
S2d4	4 <sup>th</sup> holiday defrost start (Section 2)	0 + 23h 50 min. - nu	nu	Pr2
S2d5	5 <sup>th</sup> holiday defrost start (Section 2)	0 + 23h 50 min. - nu	nu	Pr2
S2d6	6 <sup>th</sup> holiday defrost start (Section 2)	0 + 23h 50 min. - nu	nu	Pr2
<b>UTILITY</b>				
Adr1	RS485 serial address, section 1	1+247	1	Pr2
Adr2	RS485 serial address, section 2	1+247	1	Pr2
dP1	Thermostat 1 probe value	---	---	Pr1
dP2	Thermostat 2 probe value	---	---	Pr1
dP3	Evaporator probe value	---	---	Pr1
rEL	Release software	---	---	Pr2
Ptb	Parameter table	---	---	Pr2
Pr2	Access to the protected parameter list		---	Pr1

**dixell S.p.a.**

Z.I. Via dell'Industria, 27 - 32010 Pieve d'Alpago (BL) ITALY

tel. +39 - 0437 - 98 33 - fax +39 - 0437 - 98 93 13

<http://www.dixell.com> E-mail: [dixell@dixell.com](mailto:dixell@dixell.com)