

Vibration Eliminators

The function of a Vibration Eliminator is to absorb compressor vibration.

By installing a vibration eliminator, the risk of damage to system equipment and pipework is reduced.

The V Series

Each unit is constructed of a deep pitch corrugated hose covered with a stainless steel braid. The hose and braid are reinforced by ferrules at each end and connected to copper tube ends by a high temperature braze alloy.

The VS Series

The VS series is based on the proven design of the V series with a few modifications. The VS series is constructed entirely of stainless steel and all joints are tig welded. Consequently there is no need to wet-rag the product during the installation process. The maximum working pressures are higher, as detailed in the table.

A vibration eliminator is suited for installation in both the suction and discharge lines of refrigeration and air-conditioning systems.

Vibration eliminators are suitable for HCFC, HFC and CO₂ refrigerants, along with their associated oils.



V-Series



VS-Series

Manufacturing Standards

Manufactured to CE and UL classifications

Safe Working Pressure: As per table

Allowable Operating Temperature: -40°C to 120°C

Features

- Proven design.
- Large hose ID.
- Stainless steel hose and braid.
- Stainless steel ferrules.
- Helium leak tested.
- CE marked and UL listed (V series only).
- VS Series constructed entirely of stainless steel.
- Features VS Series rated to 60 bar MWP up to 1-3/8" I.D.

Benefits

- Long service life.
- Minimal pressure drop.
- Corrosion resistant.
- Superior strength.
- Leak proof.
- Fully tested to recognised international standards.
- No need to wet rag the VS series during installation.
- Ideal for CO₂ (sub-critical) applications.

Installation – Main issues

Take special care to install vibration eliminators horizontally when used in suction lines or where operating temperatures are below freezing point. Condensation may form on the outside of the unit and if installed vertically this may accumulate in the lower braid collar. In subsequent freezing this may deform and destroy the unit. If vertical installation is the only option, or indeed if condensation is possible with horizontal mounting, the entire flexible section, ferrules and braided hose, must be covered with a watertight synthetic material e.g. a heat shrinkable PVC sleeve.

The ferrule and start of braid must be wet-ragged for brazing when installing the V series to prevent overheating and subsequent damage.

The V Series

Each unit is constructed of a deep pitch corrugated hose covered with a stainless steel braid. The hose and braid are reinforced by ferrules at each end and connected to copper tube ends by a high temperature braze alloy.

The VS Series

The VS Series is based on the proven design of the V series with a few modifications. The VS series is constructed entirely of stainless steel and all joints are TIG welded. Consequently there is no need to wet-rag the product during the installation process. The maximum working pressures are higher, as detailed in the table.

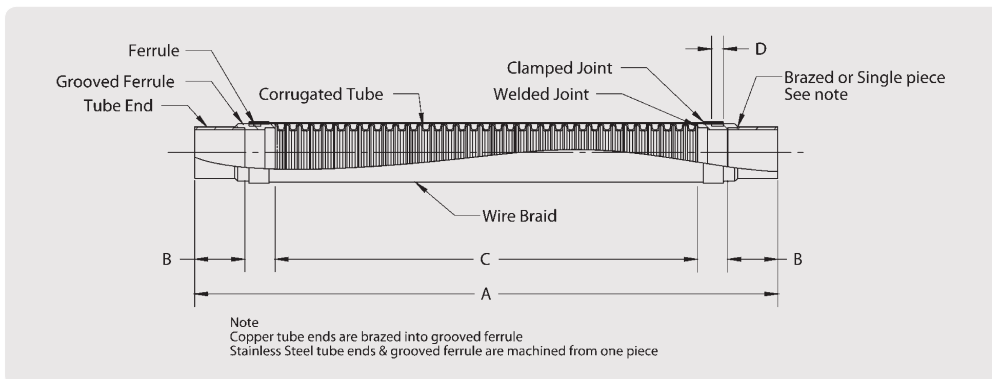

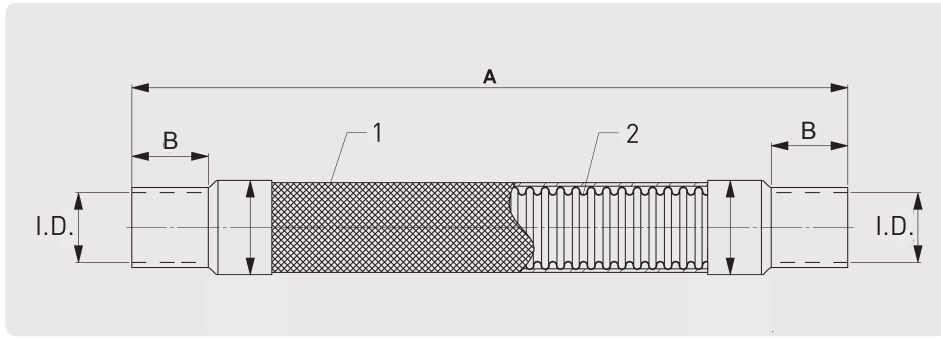

Part No.		Connection Size ID (Inch)	Dimensions		Hose Internal Dia.	MWP (kPa)		Weight (kg)
V Series	VS Series		A	B		V Series	VS Series	
V-3/8	VS-3/8	3/8	215	18	10	4480	6000	0.14
V-1/2	VS-1/2	1/2	225	18	13	4480	6000	0.15
V-5/8	VS-5/8	5/8	247	20	16	4480	6000	0.21
V-3/4	-	3/4	266	23	19	4480	6000	0.32
V-7/8	-	7/8	301	25	23	4480	6000	0.31
V-1-1/8	VS-1-1/8	1 1/8	329	32	29	4130	6000	0.42
V-1-3/8	VS-1-3/8	1 3/8	392	35	35	3790	6000	0.66
V-1-5/8	-	1 5/8	425	40	42	3510	6000	0.98
V-2-1/8	-	2 1/8	520	50	55	2750	-	1.46
V-2-5/8	-	2 5/8	613	60	67	2410	-	2.60
V-3-1/8	-	3 1/8	680	70	80	2200	-	3.60

Single system

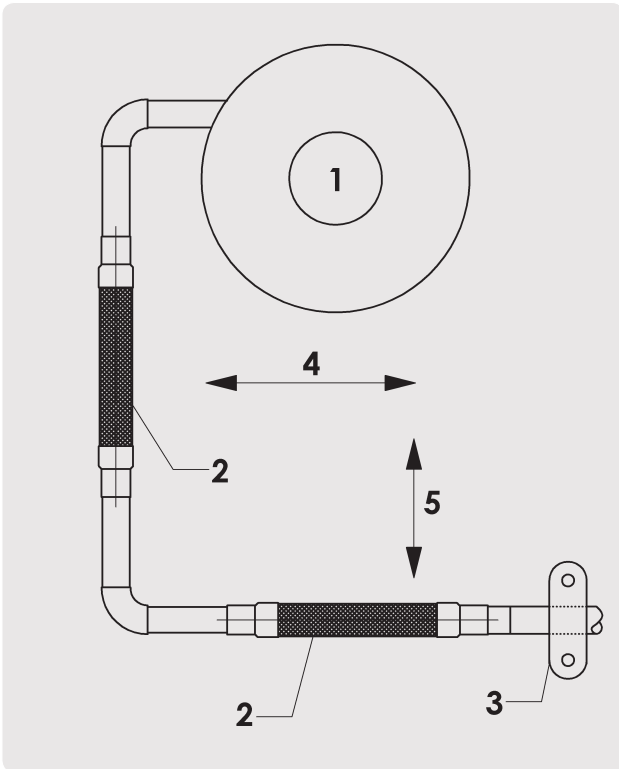

Double system

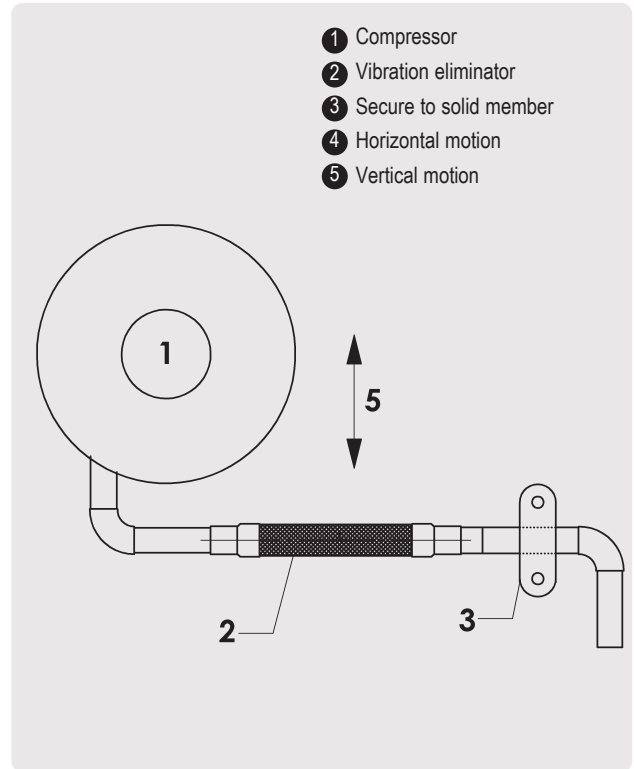

- ① Compressor
- ② Vibration eliminator
- ③ Secure to solid member
- ④ Horizontal motion
- ⑤ Vertical motion