

Installation and Operating Instructions

XH20P

Relative Humidity probe with 4÷20mA or 0÷10V Output (0i÷99%)
and NTC temperature probe

1. GENERAL WARNINGS.

1.1 THE FOLLOWING SPECIFICATIONS MUST BE READ BEFORE PROCEEDING FURTHER IN THE USE OF THE MANUAL.

- This manual is part of the product and shall be kept near the probe for easy and quick reference.
- Check the application limits before proceeding.

1.2 SAFETY PRECAUTIONS

- The probe shall be installed by qualified personnel. In any case when the box is opened or when the probe is going to be connected to the instrument, standard protection measures, to avoid electrostatic discharge, have to be taken.
- Check the supply voltage is correct before connecting the probe.
- Warning: disconnect all electrical connections before any kind of maintenance.
- Make sure that the wires for probes and power wires are separated and far enough from each other.
- In case of failure or faulty operation send the probe back to the retailer with a detailed description of the fault.

2. GENERAL DESCRIPTION

The XH20P humidity probe is suitable for all those applications where it is necessary to detect and control humidity. Such applications are: refrigeration, drying processes, air conditioning, and others.

According to the model the probe supplies a standard output: current or voltage signal (4÷20mA or 0÷10V) that covers a range of 0÷99% relative humidity for XH20P and 30÷90% for XH10P.

The high precision and the quick reply time to external changes make these probes extremely effective and reliable.

3. INSTALLATION

1. Open the box of the probe. Unscrew the screws on the lid and connect the cable to the terminals according to the model as shown at point (A).

IMPORTANT NOTE: Internal components can be damaged by electrostatic discharge

2. By means of the proper holes, fix the probe where it has to measure the humidity (B).

IMPORTANT NOTE: To avoid having problem with condensing place the probe with filter in a horizontal position or turn down.

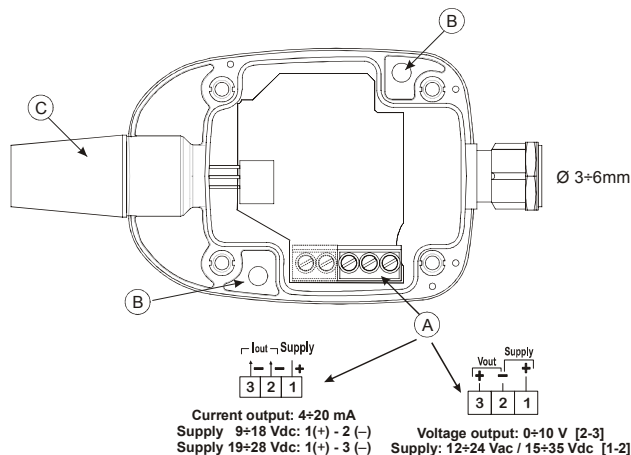

3. Close the lid as shown in fig. 1, making sure that the isolation gasket is in good condition and safely positioned in its groove.- This will guarantee a waterproof housing.
4. Disconnect the power supply from the instrument to which the humidity probe is to be connected and then carry out the connection.

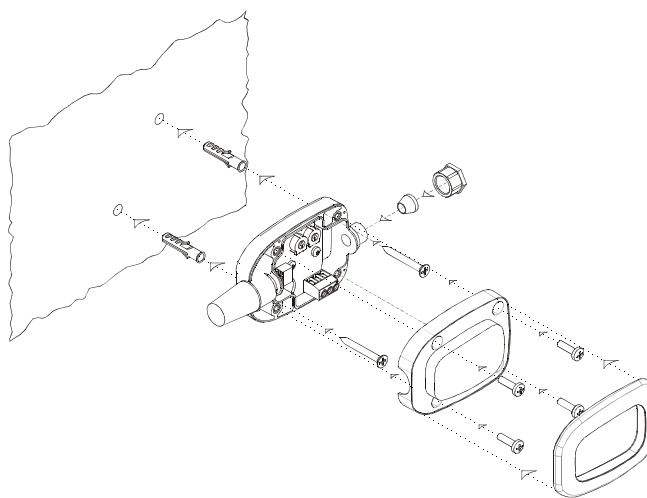
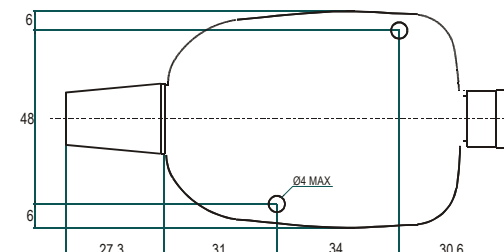

Fig. 1

4. DIMENSIONS

The dimensions of the humidity probe are the following:



5. MAINTENANCE AND CLEANING

The probe does not require particular maintenance.- However, if it is installed in particularly dusty places, the protective filter could become filled with dust, and as a consequence it would alter the humidity read.- In this case it is necessary to clean or change the filter as follows:

1. Disconnect the instrument from the power supply
2. Keep (C) on which the filter is screwed, blocked.- Now unscrew the filter by turning it anticlockwise, making sure the sensor is not extracted.

IMPORTANT NOTE: Once the protective filter has been removed, DO NOT touch the sensor, as it is sensitive to electrostatic charge.

3. Change or clean the protective filter (e.g. with compressed air from the inside towards the outside).
4. Screw it on again carefully.
5. Reconnect the instrument to the power supply.

6. TECHNICAL DATA

Power supply: according to the model: 19÷28Vdc or 9-20Vdc or 15÷35Vdc

Power consumption: 20mA max

Connection: 2 not polarised wires

Max cross wires: 2,5mm²

Output: 4÷20mA or 0÷10Vdc

Measurement range: 0÷99% R. H.

Protection: IP65

Operating range: 0÷70 °C

Storage range: -30÷85 °C

RH response time: 15 sec in slowly moving air at 25°C

Accuracy at 25°C: better than 3% F. S.

