

ENGINEERING
TOMORROW

Danfoss

Quick reference

Maneurop[®] reciprocating compressors **MT - MTZ - NTZ**

50 Hz - R404A - R507 - R407C - R134a - R22 - R407A - R407F



Quick reference

Dimensions

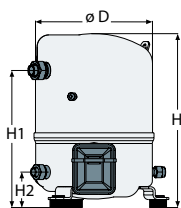

MT / MTZ / NTZ
1 cylinder

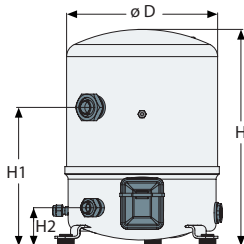

MT / MTZ / NTZ
2 cylinders

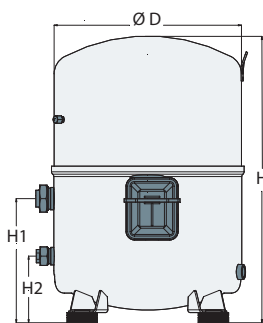

MT / MTZ / NTZ
4 cylinders

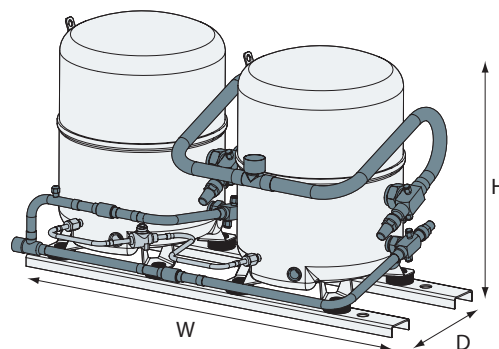

MT / MTZ Tandem
2 x 4 cylinders

Single compressors (all dimensions in mm)

	D	H	H1	H2
1 cylinder	224	333 / 358	263	68
2 cylinders	288	413	265	74
4 cylinders	352	519 / 540	233	128

Tandem model (all dimensions in mm)

	H	D	W
2 x 4 cylinders	544/565	515	925

Nomenclature

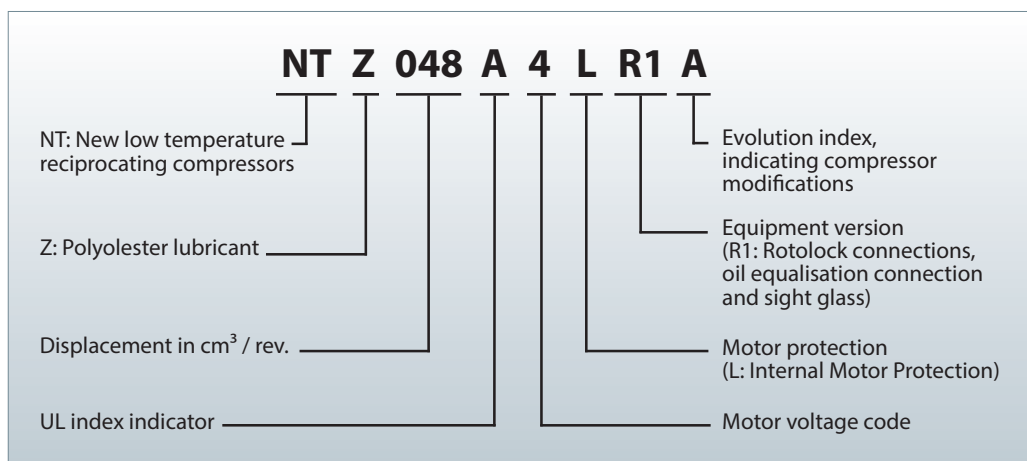
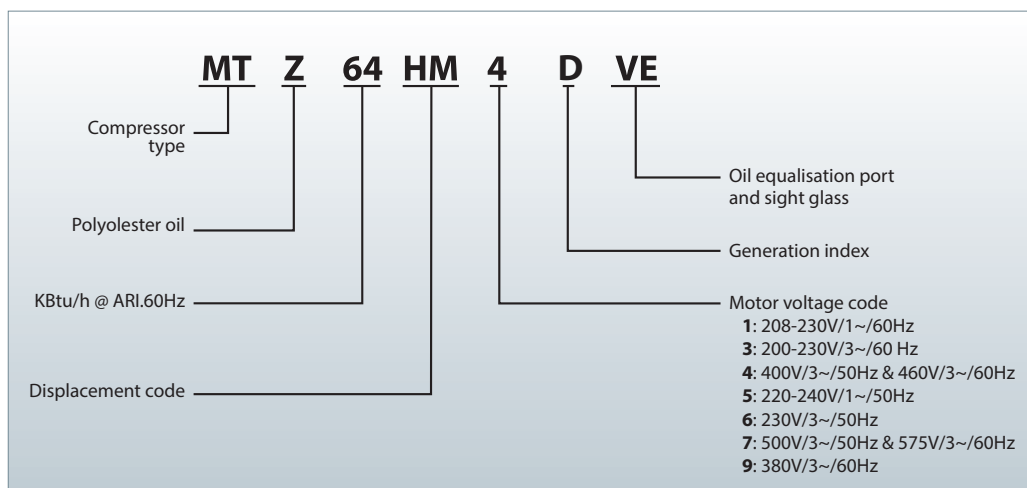

Quick reference
Code numbers for ordering single pack compressors

	Model	4	5	6	7	Swept volume cm ³ /rev	Displacement m ³ /h at 2900 rpm	Cylinder number	Oil charge dm ³	Net weight kg
		460/3/60 400/3/50	230/1/50	230/3/50	575/3/60 500/3/50					
Low back pressure applications	NTZ048	120F0001	120F0087	-	-	48	8.4	1	0.95	21
	NTZ068	120F0002	120F0088	-	-	68	11.8	1	0.95	23
	NTZ096	120F0003	-	-	-	96	16.7	2	1.8	35
	NTZ108	120F0004	-	-	-	108	18.7	2	1.8	35
	NTZ136	120F0005	-	-	-	136	23.6	2	1.8	35
	NTZ215	120F0006	-	-	-	215	37.5	4	3.9	62
	NTZ271	120F0007	-	-	-	271	47.3	4	3.9	64
Medium-High back pressure applications	MT018	MT18-4VI	MT18-5VI	-	-	30	5.3	1	0.95	21
	MT022	MT22-4VI	MT22-5VI	MT22-6VI	-	38	6.6	1	0.95	21
	MT028	MT28-4VI	MT28-5VI	MT28-6VI	-	48	8.4	1	0.95	23
	MT032	MT32-4VI	MT32-5VI	MT32-6VI	-	54	9.4	1	0.95	24
	MT036	MT36-4VI	MT36-5VI	MT36-6VI	-	60	10.5	1	0.95	25
	MT040	MT40-4VI	-	MT40-6VI	-	68	11.8	1	0.95	26
	MT044	MT44-4VI	-	MT44-6VI	-	76	13.3	2	1.8	37
	MT050	MT50-4VI	-	MT50-6VI	MT50-7VI	86	14.9	2	1.8	37
	MT056	MT56-4VI	-	MT56-6VI	MT56-7VI	96	16.7	2	1.8	39
	MT064	MT64-4VI	-	MT64-6VI	-	108	18.7	2	1.8	39
	MT072	MT72-4VI	-	MT72-6VI	-	121	21.0	2	1.8	40
	MT080	MT80-4VI	-	MT80-6VI	-	136	23.6	2	1.8	40
	MT100	MT100-4VI	-	MT100-6VI	MT100-7VI	171	29.8	4	3.9	60
	MT125	MT125-4VI	-	MT125-6VI	MT125-7VI	215	37.5	4	3.9	64
	MT144	MT144-4VI	-	MT144-6VI	MT144-7VI	242	42.1	4	3.9	67
	MT160	MT160-4VI	-	MT160-6VI	MT160-7VI	272	47.3	4	3.9	67
	MTM200	MTM200T4SA	-	-	-	2 x 171	2 x 29.8	2 x 4	2 x 3.9	134
	MTM250	MTM250T4SA	-	-	-	2 x 215	2 x 37.5	2 x 4	2 x 3.9	142
	MTM288	MTM288T4SA	-	-	-	2 x 242	2 x 42.1	2 x 4	2 x 3.9	148
	MTM320	MTM320T4SA	-	-	-	2 x 272	2 x 47.3	2 x 4	2 x 3.9	148
	MTZ018	MTZ18-4VI	MTZ18-5VI	MTZ18-6VI	-	30	5.3	1	0.95	21
	MTZ022	MTZ22-4VI	MTZ22-5VI	MTZ22-6VI	-	38	6.6	1	0.95	21
	MTZ028	MTZ28-4VI	MTZ28-5VI	MTZ28-6VI	-	48	8.4	1	0.95	23
	MTZ032	MTZ32-4VI	MTZ32-5VI	MTZ32-6VI	MTZ32-7VI	54	9.4	1	0.95	24
	MTZ036	MTZ36-4VI	MTZ36-5VI	MTZ36-6VI	MTZ36-7VI	60	10.5	1	0.95	25
	MTZ040	MTZ40-4VI	-	MTZ40-6VI	-	68	11.8	1	0.95	26
	MTZ044	MTZ44-4VI	-	MTZ44-6VI	MTZ44-7VI	76	13.3	2	1.8	37
	MTZ050	MTZ50-4VI	-	MTZ50-6VI	MTZ50-7VI	86	14.9	2	1.8	37
	MTZ056	MTZ56-4VI	-	MTZ56-6VI	MTZ56-7VI	96	16.7	2	1.8	39
	MTZ064	MTZ64-4VI	-	MTZ64-6VI	-	108	18.7	2	1.8	39
	MTZ072	MTZ72-4VI	-	MTZ72-6VI	-	121	21.0	2	1.8	40
	MTZ080	MTZ80-4VI	-	MTZ80-6VI	-	136	23.6	2	1.8	40
MTZ100	MTZ100-4VI	-	MTZ100-6VI	MTZ100-7VI	171	29.8	4	3.9	60	
MTZ125	MTZ125-4VI	-	MTZ125-6VI	MTZ125-7VI	215	37.5	4	3.9	64	
MTZ144	MTZ144-4VI	-	MTZ144-6VI	MTZ144-7VI	242	42.1	4	3.9	67	
MTZ160	MTZ160-4VI	-	MTZ160-6VI	MTZ160-7VI	272	47.3	4	3.9	67	
MTZ200	MTZ200T4SA	-	-	-	2 x 171	2 x 29.8	2 x 4	2 x 3.9	134	
MTZ250	MTZ250T4SA	-	-	-	2 x 215	2 x 37.5	2 x 4	2 x 3.9	142	
MTZ288	MTZ288T4SA	-	-	-	2 x 242	2 x 42.1	2 x 4	2 x 3.9	148	
MTZ320	MTZ320T4SA	-	-	-	2 x 272	2 x 47.3	2 x 4	2 x 3.9	148	

Quick reference

Performance data

NTZ - R404A/R507

Model	To	-45		-40		-35		-30		-25		-20		-15		-10	
	Tc	Qo	Pe	Qo	Pe	Qo	Pe	Qo	Pe	Qo	Pe	Qo	Pe	Qo	Pe	Qo	Pe
NTZ048-4	45	190	0.35	420	0.59	710	0.84	1240	1.09	1700	1.34	2240	1.57	2860	1.79	3570	1.99
NTZ068-4	45	520	1.02	870	1.28	1290	1.54	2110	1.81	2790	2.09	3570	2.38	4490	2.68	5540	2.99
NTZ096-4	45	-	-	910	1.29	1420	1.67	2430	2.09	3360	2.53	4510	2.99	5900	3.48	7550	3.97
NTZ108-4	45	-	-	1120	1.57	1770	2.03	3010	2.49	4080	2.95	5340	3.40	6820	3.85	8530	4.29
NTZ136-4	45	-	-	1570	2.27	2360	2.86	3890	3.47	5200	4.08	6750	4.69	8570	5.29	10710	5.87
NTZ215-4	45	1190	2.31	2240	3.17	3540	4.08	5970	5.01	8030	5.94	10440	6.86	13220	7.72	16420	8.52
NTZ271-4	45	2120	3.57	3470	4.61	5140	5.66	8380	6.73	11050	7.81	14190	8.90	17840	10.00	22040	11.10

Legend: To: Evaporating temperature in °C Qo: Cooling capacity in W Superheat = 10K; Subcooling = 0 K Voltage: 400V / 3 / 50 Hz
Tc: Condensing temperature in °C Pe: Power input in kW Suction temp. = 20°C; Subcooling = 0 K

MT - R22

Model	To	-25		-20		-15		-10		-5		0		5		10		15	
	Tc	Qo	Pe	Qo	Pe	Qo	Pe	Qo	Pe	Qo	Pe	Qo	Pe	Qo	Pe	Qo	Pe	Qo	Pe
MT018-4	45	570	0.64	890	0.77	1300	0.88	1810	1.00	2450	1.10	3220	1.19	4150	1.26	5260	1.31	6550	1.33
MT022-4	45	740	0.77	1280	0.95	1920	1.12	2670	1.29	3540	1.44	4560	1.56	5720	1.66	7040	1.73	8550	1.76
MT028-4	45	1460	1.22	2190	1.43	3030	1.63	4000	1.81	5090	1.98	6330	2.11	7720	2.20	9280	2.25	11020	2.24
MT032-4	45	1550	1.46	2310	1.68	3190	1.90	4230	2.11	5440	2.31	6830	2.47	8420	2.60	10240	2.69	12300	2.74
MT036-4	45	1960	1.68	2890	1.90	3950	2.13	5150	2.35	6500	2.56	8020	2.76	9710	2.93	11600	3.07	13680	3.17
MT040-4	45	2050	1.77	3080	2.08	4260	2.39	5590	2.67	7090	2.93	8780	3.15	10670	3.32	12760	3.42	15080	3.45
MT044-4	45	1920	1.70	2760	1.97	3850	2.22	5210	2.46	6880	2.68	8870	2.88	11230	3.07	13970	3.23	17120	3.38
MT050-4	45	2170	1.93	3300	2.31	4660	2.65	6290	2.94	8210	3.20	10460	3.42	13050	3.61	16010	3.77	19380	3.92
MT056-4	45	2680	2.20	3770	2.55	5170	2.88	6910	3.18	9020	3.46	11530	3.72	14490	3.96	17920	4.18	21850	4.38
MT064-4	45	3140	2.40	4580	2.85	6290	3.27	8310	3.64	10670	3.98	13420	4.27	16590	4.53	20200	4.76	24300	4.94
MT072-4	45	3240	2.61	4950	3.20	6960	3.72	9330	4.19	12110	4.60	15320	4.96	19020	5.27	23260	5.54	28070	5.78
MT080-4	45	4230	3.32	6180	3.89	8450	4.41	11100	4.89	14170	5.33	17690	5.72	21720	6.09	26290	6.42	31460	6.72
MT100-4	45	4570	4.06	6650	4.66	9150	5.25	12140	5.79	15690	6.27	19870	6.66	24730	6.94	30360	7.09	36820	7.08
MT125-4	45	6690	5.48	9360	6.17	12550	6.87	16350	7.55	20850	8.18	26120	8.75	32240	9.24	39310	9.63	47400	9.88
MT144-4	45	7700	6.16	10660	6.94	14230	7.71	18510	8.47	23600	9.17	29590	9.81	36590	10.36	44690	10.80	53990	11.09
MT160-4	45	8660	6.93	11920	7.79	15850	8.65	20560	9.49	26170	10.28	32790	11.00	40520	11.61	49470	12.10	59750	12.44
MTM200-4	45	9140	8.12	13300	9.32	18300	10.49	24280	11.58	31380	12.54	39730	13.32	49470	13.89	60720	14.19	73640	14.17
MTM250-4	45	13390	10.95	18720	12.35	25100	13.74	32700	15.09	41690	16.36	52230	17.51	64490	18.49	78630	19.25	94810	19.77
MTM288-4	45	15390	12.32	21320	13.87	28460	15.42	37030	16.93	47200	18.35	59190	19.63	73180	20.72	89380	21.59	107990	22.18
MTM320-4	45	17330	13.86	23840	15.58	31700	17.30	41130	18.99	52350	20.57	65580	22.00	81030	23.22	98930	24.20	119500	24.88

Legend: To: Evaporating temperature in °C Qo: Cooling capacity in W Superheat = 11.1 K Voltage: 400V / 3 / 50 Hz
Tc: Condensing temperature in °C Pe: Power input in kW Subcooling = 8.3 K

Quick reference

Performance data

MTZ - R407C

Model	To	-15		-10		-5		0		5		10		15	
	Tc	Qo	Pe	Qo	Pe	Qo	Pe	Qo	Pe	Qo	Pe	Qo	Pe	Qo	Pe
MTZ018-4	45	1170	0.82	1750	0.94	2430	1.04	3230	1.13	4170	1.20	5260	1.26	6510	1.30
MTZ022-4	45	1760	1.07	2480	1.24	3320	1.39	4300	1.50	5450	1.60	6770	1.67	8280	1.73
MTZ028-4	45	2150	1.30	3100	1.52	4210	1.72	5500	1.89	7010	2.03	8740	2.13	10730	2.21
MTZ032-4	45	2700	1.50	3730	1.75	4920	1.95	6310	2.12	7920	2.27	9770	2.38	11880	2.48
MTZ036-4	45	3260	1.81	4390	2.10	5690	2.36	7180	2.57	8900	2.74	10850	2.86	13070	2.95
MTZ040-4	45	3870	2.18	5130	2.48	6590	2.74	8270	2.98	10200	3.18	12410	3.35	14930	3.48
MTZ044-4	45	3550	1.97	4900	2.28	6570	2.54	8580	2.76	10980	2.94	13810	3.10	17090	3.24
MTZ050-4	45	4190	2.34	5760	2.70	7630	3.00	9840	3.24	12430	3.45	15460	3.61	18970	3.75
MTZ056-4	45	4520	2.50	6290	2.90	8410	3.24	10930	3.53	13890	3.78	17360	3.98	21370	4.16
MTZ064-4	45	5530	2.91	7460	3.35	9790	3.73	12580	4.05	15880	4.32	19750	4.57	24230	4.79
MTZ072-4	45	6280	3.49	8520	3.96	11200	4.39	14400	4.77	18160	5.11	22540	5.39	27600	5.63
MTZ080-4	45	7260	4.08	9830	4.64	12840	5.12	16380	5.54	20490	5.89	25260	6.19	30730	6.45
MTZ100-4	45	7840	4.81	10990	5.47	14750	6.04	19220	6.52	24470	6.92	30590	7.26	37650	7.56
MTZ125-4	45	11460	6.13	15420	6.97	20060	7.69	25500	8.31	31820	8.84	39140	9.30	47550	9.69
MTZ144-4	45	12610	7.07	16970	7.92	22120	8.70	28160	9.42	35210	10.04	43380	10.58	52780	11.01
MTZ160-4	45	15310	8.21	20110	9.20	25770	10.09	32430	10.91	40220	11.68	49270	12.42	59700	13.16
MTZ200-4	45	15690	9.61	21980	10.94	29510	12.08	38450	13.03	48950	13.84	61180	14.53	75300	15.11
MTZ250-4	45	22930	12.26	30840	13.93	40120	15.37	50990	16.61	63640	17.68	78280	18.59	95100	19.38
MTZ288-4	45	25220	14.13	33940	15.83	44230	17.41	56320	18.83	70420	20.09	86760	21.16	105560	22.02
MTZ320-4	45	30630	16.42	40210	18.39	51540	20.17	64860	21.81	80450	23.36	98540	24.85	119400	26.32

Legend: To: Evaporating temperature in °C Qo: Cooling capacity in W Superheat = 11.1 K Voltage: 400 V / 3 / 50 Hz
Tc: Condensing temperature in °C Pe: Power input in kW Subcooling = 8.3 K

MTZ - R134a

Model	To	-15		-10		-5		0		5		10		15		20	
	Tc	Qo	Pe	Qo	Pe	Qo	Pe	Qo	Pe	Qo	Pe	Qo	Pe	Qo	Pe	Qo	Pe
MTZ018-4	45	700	0.61	1050	0.69	1470	0.76	1970	0.82	2570	0.87	3270	0.91	4090	0.93	5020	0.93
MTZ022-4	45	940	0.72	1370	0.82	1900	0.91	2550	0.99	3320	1.06	4240	1.11	5310	1.15	6560	1.16
MTZ028-4	45	1230	0.91	1720	1.02	2350	1.13	3130	1.24	4090	1.34	5260	1.43	6650	1.51	8300	1.58
MTZ032-4	45	1430	1.09	2020	1.25	2770	1.40	3690	1.54	4810	1.66	6160	1.76	7760	1.83	9630	1.86
MTZ036-4	45	2050	1.30	2740	1.45	3580	1.60	4590	1.74	5780	1.87	7170	1.97	8790	2.05	10660	2.10
MTZ040-4	45	2450	1.47	3160	1.61	4000	1.75	4980	1.89	6100	2.01	7390	2.12	8860	2.21	10520	2.27
MTZ044-4	45	2080	1.29	2910	1.49	3940	1.68	5190	1.83	6710	1.95	8540	2.05	10710	2.13	13270	2.17
MTZ050-4	45	2360	1.57	3340	1.80	4560	2.00	6040	2.17	7820	2.31	9950	2.43	12470	2.51	15410	2.57
MTZ056-4	45	2290	1.64	3380	1.88	4730	2.11	6400	2.31	8420	2.49	10820	2.65	13650	2.77	16940	2.86
MTZ064-4	45	2700	1.87	4010	2.17	5600	2.43	7510	2.67	9780	2.87	12440	3.04	15550	3.18	19130	3.27
MTZ072-4	45	3200	2.16	4660	2.50	6430	2.81	8560	3.08	11090	3.33	14070	3.54	17540	3.74	21560	3.92
MTZ080-4	45	4130	2.59	5700	2.93	7620	3.24	9950	3.54	12740	3.80	16040	4.05	19920	4.28	24430	4.48
MTZ100-4	45	4660	3.25	6550	3.65	8860	4.02	11680	4.35	15050	4.63	19050	4.84	23730	4.96	29170	4.98
MTZ125-4	45	5870	3.63	8230	4.17	11090	4.69	14520	5.16	18590	5.57	23380	5.89	28960	6.09	35390	6.18
MTZ144-4	45	7880	4.85	10680	5.40	14060	5.94	18090	6.46	22850	6.93	28420	7.34	34870	7.67	42290	7.92
MTZ160-4	45	8770	5.23	11800	5.84	15470	6.45	19890	7.06	25130	7.65	31300	8.21	38480	8.72	46770	9.18
MTZ200-4	45	9320	6.50	13090	7.29	17730	8.04	23350	8.70	30100	9.26	38090	9.68	47460	9.92	58340	9.96
MTZ250-4	45	11740	7.25	16460	8.35	22180	9.39	29040	10.33	37190	11.14	46770	11.77	57910	12.19	70770	12.35
MTZ288-4	45	15750	9.71	21370	10.81	28130	11.89	36190	12.91	45710	13.85	56840	14.67	69750	15.35	84590	15.84
MTZ320-4	45	17540	10.46	23600	11.67	30950	12.90	39780	14.11	50260	15.29	62600	16.41	76960	17.44	93530	18.37

Legend: To: Evaporating temperature in °C Qo: Cooling capacity in W Superheat = 10 K Voltage: 400 V / 3 / 50 Hz
Tc: Condensing temperature in °C Pe: Power input in kW Subcooling = 0 K

Quick reference

Performance data

MTZ - R404A/R507

Model	To	-30			-25			-20			-15			-10			-5			0			5			10		
		Tc	Qo	Pe	Qo	Pe	Qo	Pe	Qo	Pe	Qo	Pe	Qo	Pe	Qo	Pe	Qo	Pe	Qo	Pe	Qo	Pe	Qo	Pe	Qo	Pe		
MTZ018-4	45	390	0.69	650	0.83	980	0.97	1400	1.09	1900	1.21	2520	1.31	3250	1.40	4110	1.47	5120	1.53									
MTZ022-4	45	640	0.86	980	1.03	1410	1.19	1960	1.34	2620	1.48	3440	1.61	4410	1.72	5550	1.82	6880	1.90									
MTZ028-4	45	760	1.05	1250	1.30	1850	1.53	2570	1.75	3430	1.96	4450	2.14	5640	2.31	7040	2.45	8640	2.56									
MTZ032-4	45	1040	1.20	1580	1.46	2240	1.71	3030	1.94	3980	2.16	5110	2.36	6440	2.55	7980	2.71	9760	2.86									
MTZ036-4	45	1300	1.50	1930	1.78	2690	2.06	3600	2.33	4670	2.58	5930	2.81	7400	3.01	9100	3.19	11050	3.34									
MTZ040-4	45	1600	1.70	2320	2.05	3160	2.37	4160	2.67	5330	2.95	6700	3.21	8290	3.44	10130	3.65	12230	3.84									
MTZ044-4	45	1360	1.60	2100	1.94	2990	2.25	4070	2.53	5370	2.78	6910	3.00	8740	3.20	10890	3.38	13370	3.54									
MTZ050-4	45	1700	1.94	2500	2.29	3510	2.62	4750	2.93	6260	3.22	8070	3.48	10220	3.71	12740	3.91	15680	4.07									
MTZ056-4	45	1730	2.04	2620	2.43	3710	2.81	5060	3.17	6710	3.51	8690	3.83	11060	4.11	13840	4.36	17090	4.57									
MTZ064-4	45	2160	2.32	3200	2.83	4480	3.32	6060	3.78	7980	4.20	10300	4.60	13070	4.96	16330	5.28	20150	5.55									
MTZ072-4	45	2550	2.74	3670	3.25	5080	3.75	6810	4.23	8920	4.69	11450	5.11	14450	5.51	17970	5.87	22050	6.19									
MTZ080-4	45	3170	3.15	4530	3.85	6170	4.48	8130	5.07	10470	5.61	13230	6.11	16470	6.57	20240	7.01	24580	7.41									
MTZ100-4	45	3240	4.01	4930	4.80	6960	5.53	9390	6.18	12280	6.76	15700	7.27	19710	7.70	24370	8.06	29760	8.34									
MTZ125-4	45	4660	5.16	6620	6.02	9060	6.86	12060	7.67	15710	8.44	20080	9.16	25250	9.83	31300	10.44	38310	10.98									
MTZ144-4	45	5700	6.08	8060	7.05	10920	8.00	14370	8.91	18490	9.78	23380	10.60	29110	11.36	35770	12.06	43450	12.69									
MTZ160-4	45	6280	6.80	8870	7.95	12010	9.04	15790	10.08	20310	11.08	25640	12.05	31900	13.01	39160	13.98	47540	14.95									
MTZ200-4	45	6480	8.02	9860	9.60	13920	11.05	18770	12.36	24560	13.52	31400	14.53	39420	15.39	48750	16.11	59510	16.68									
MTZ250-4	45	9320	10.32	13230	12.05	18110	13.73	24120	15.34	31420	16.88	40160	18.32	50500	19.66	62600	20.88	76620	21.96									
MTZ288-4	45	11410	12.17	16120	14.11	21840	16.00	28740	17.82	36990	19.56	46760	21.20	58220	22.72	71550	24.12	86900	25.37									
MTZ320-4	45	12550	13.61	17740	15.90	24030	18.08	31590	20.15	40610	22.15	51280	24.10	63790	26.03	78330	27.95	95070	29.90									

Legend: To: Evaporating temperature in °C Qo: Cooling capacity in W Superheat = 10 K Voltage: 400 V / 3 / 50 Hz
Tc: Condensing temperature in °C Pe: Power input in kW Subcooling = 0 K

Quick reference

Performance data

MTZ - R407A

Model	To	-30			-25			-20			-15			-10			-5			0			5			10		
	Tc	Qo	Pe	Qo	Pe	Qo	Pe	Qo	Pe	Qo	Pe	Qo	Pe	Qo	Pe	Qo	Pe	Qo	Pe	Qo	Pe	Qo	Pe	Qo	Pe			
MTZ018-4	45	260	0.49	510	0.63	830	0.76	1240	0.90	1740	1.02	2340	1.14	3070	1.24	3930	1.32	4940	1.39									
MTZ022-4	45	430	0.60	760	0.77	1190	0.94	1730	1.10	2390	1.26	3200	1.40	4170	1.53	5300	1.64	6630	1.72									
MTZ028-4	45	510	0.74	990	0.99	1570	1.23	2280	1.46	3130	1.67	4140	1.86	5330	2.03	6720	2.19	8330	2.32									
MTZ032-4	45	700	0.85	1240	1.11	1890	1.37	2690	1.61	3630	1.84	4760	2.05	6080	2.25	7630	2.43	9400	2.59									
MTZ036-4	45	870	1.06	1510	1.35	2270	1.64	3180	1.92	4260	2.19	5520	2.44	7000	2.66	8700	2.86	10670	3.03									
MTZ040-4	45	1070	1.21	1830	1.56	2700	1.90	3710	2.22	4890	2.51	6250	2.79	7840	3.04	9670	3.27	11760	3.47									
MTZ044-4	45	920	1.13	1630	1.47	2520	1.79	3590	2.09	4890	2.36	6440	2.60	8270	2.83	10410	3.03	12890	3.20									
MTZ050-4	45	1140	1.36	1940	1.73	2950	2.08	4190	2.42	5700	2.73	7520	3.02	9670	3.28	12190	3.50	15120	3.69									
MTZ056-4	45	1160	1.43	2030	1.84	3120	2.24	4470	2.62	6120	2.98	8100	3.32	10460	3.63	13240	3.91	16480	4.15									
MTZ064-4	45	1450	1.64	2480	2.15	3760	2.64	5340	3.12	7270	3.57	9600	3.99	12360	4.38	15620	4.73	19420	5.03									
MTZ072-4	45	1710	1.93	2850	2.46	4260	2.98	6010	3.49	8130	3.98	10670	4.44	13680	4.88	17190	5.27	21260	5.61									
MTZ080-4	45	2130	2.23	3520	2.91	5190	3.57	7180	4.18	9540	4.76	12330	5.31	15590	5.81	19360	6.28	23710	6.72									
MTZ100-4	45	2170	2.83	3860	3.64	5880	4.41	8300	5.11	11200	5.74	14620	6.31	18640	6.80	23310	7.22	28700	7.56									
MTZ125-4	45	3130	3.65	5130	4.56	7610	5.46	10650	6.33	14330	7.17	18710	7.96	23890	8.70	29950	9.36	36940	9.95									
MTZ144-4	45	3830	4.33	6270	5.37	9190	6.39	12700	7.38	16870	8.32	21780	9.21	27540	10.04	34220	10.81	41910	11.49									
MTZ160-4	45	4220	4.84	6900	6.05	10120	7.21	13960	8.33	18520	9.42	23890	10.48	30180	11.51	37470	12.53	45860	13.53									
MTZ200-4	45	4300	5.65	7700	7.29	11800	8.81	16600	10.21	22400	11.48	29200	12.61	37300	13.60	46600	14.44	57400	15.13									
MTZ250-4	45	6300	7.31	10300	9.12	15200	10.91	21300	12.66	28700	14.34	37400	15.92	47800	17.39	59900	18.73	73890	19.89									
MTZ288-4	45	7700	8.66	12500	10.74	18400	12.78	25400	14.75	33700	16.64	43600	18.42	55100	20.09	68400	21.61	83830	22.99									
MTZ320-4	45	8400	9.69	13800	12.10	20200	14.42	27900	16.66	37000	18.84	47800	20.96	60400	23.02	74900	25.06	91720	27.06									

Legend: To: Evaporating temperature in °C Qo: Cooling capacity in W Superheat = 10 K Voltage: 400 V / 3 / 50 Hz
Tc: Condensing temperature in °C Pe: Power input in kW Subcooling = 0 K

MTZ - R407F

Model	To	-25			-20			-15			-10			-5			0			5			10				
	Tc	Qo	Pe	Qo	Pe	Qo	Pe	Qo	Pe	Qo	Pe	Qo	Pe	Qo	Pe	Qo	Pe	Qo	Pe	Qo	Pe	Qo	Pe				
MTZ018-4	45	540	0.70	890	0.83	1320	0.96	1850	1.08	2490	1.20	3260	1.30	4170	1.39	5230	1.44										
MTZ022-4	45	810	0.86	1270	1.02	1840	1.18	2540	1.33	3400	1.48	4410	1.61	5620	1.72	7030	1.80										
MTZ028-4	45	1030	1.09	1660	1.31	2420	1.54	3320	1.76	4390	1.97	5650	2.15	7130	2.31	8830	2.42										
MTZ032-4	45	1310	1.22	2010	1.46	2850	1.70	3860	1.94	5050	2.17	6450	2.38	8080	2.56	9970	2.71										
MTZ036-4	45	1610	1.49	2430	1.76	3390	2.04	4520	2.32	5860	2.57	7410	2.81	9210	3.01	11290	3.16										
MTZ040-4	45	1930	1.71	2850	2.02	3920	2.34	5170	2.65	6620	2.94	8300	3.21	10250	3.44	12480	3.63										
MTZ044-4	45	1750	1.62	2690	1.92	3830	2.21	5200	2.49	6830	2.75	8760	2.99	11020	3.19	13660	3.35										
MTZ050-4	45	2090	1.88	3160	2.24	4470	2.58	6060	2.90	7970	3.19	10240	3.44	12910	3.67	16020	3.85										
MTZ056-4	45	2180	2.04	3340	2.40	4770	2.78	6500	3.16	8590	3.51	11080	3.84	14020	4.11	17460	4.33										
MTZ064-4	45	2670	2.38	4040	2.84	5700	3.31	7730	3.78	10180	4.22	13100	4.63	16540	4.97	20580	5.25										
MTZ072-4	45	3060	2.74	4570	3.21	6410	3.71	8640	4.21	11310	4.69	14480	5.14	18190	5.53	22520	5.85										
MTZ080-4	45	3790	3.23	5560	3.84	7650	4.44	10140	5.04	13070	5.61	16500	6.13	20490	6.60	25100	7.01										
MTZ100-4	45	4090	4.01	6270	4.73	8840	5.42	11900	6.07	15500	6.66	19740	7.18	24680	7.59	30400	7.89										
MTZ125-4	45	5520	5.07	8160	5.88	11360	6.73	15220	7.58	19830	8.41	25290	9.17	31700	9.84	39130	10.38										
MTZ144-4	45	6730	5.92	9840	6.85	13530	7.81	17910	8.78	23090	9.72	29160	10.60	36220	11.36	44370	11.99										
MTZ160-4	45	7420	6.70	10820	7.75	14870	8.84	19670	9.95	25320	11.05	31950	12.13	39650	13.16	48540	14.12										
MTZ200-4	45	8200	8.01	12500	9.45	17700	10.84	23800	12.14	31000	13.33	39500	14.35	49400	15.18	60800	15.78										
MTZ250-4	45	11000	10.14	16300	11.76	22700	13.46	30400	15.16	39700	16.81	50600	18.34	63400	19.67	78300	20.75										
MTZ288-4	45	13500	11.85	19700	13.69	27100	15.62	35800	17.57	46200	19.45	58300	21.19	72400	22.73	88700	23.98										
MTZ320-4	45	14800	13.40	21700	15.50	29700	17.68	39300	19.90	50600	22.11	63900	24.27	79300	26.32	97100	28.23										

Legend: To: Evaporating temperature in °C Qo: Cooling capacity in W Superheat = 10 K Voltage: 400 V / 3 / 50 Hz
Tc: Condensing temperature in °C Pe: Power input in kW Subcooling = 0 K

Danfoss Commercial Compressors

is a worldwide manufacturer of compressors and condensing units for refrigeration and HVAC applications. With a wide range of high quality and innovative products we help your company to find the best possible energy efficient solution that respects the environment and reduces total life cycle costs.

We have 40 years of experience within the development of hermetic compressors which has brought us amongst the global leaders in our business, and positioned us as distinct variable speed technology specialists. Today we operate from engineering and manufacturing facilities spread across three continents.

 <p>Danfoss Scrolls</p>	 <p>Danfoss Inverter Scrolls</p>	 <p>Danfoss Turbocor Compressors</p>
 <p>Secop Compressors for Danfoss</p>	 <p>Danfoss Maneurop Reciprocating Compressors</p>	 <p>Danfoss Optyma Condensing Units</p>

Our products can be found in a variety of applications such as rooftops, chillers, residential air conditioners, heatpumps, coldrooms, supermarkets, milk tank cooling and industrial cooling processes.

<http://cc.danfoss.com>

Danfoss Commercial Compressors, BP 331, 01603 Trévoux Cedex, France | +334 74 00 28 29

member of:



Danfoss can accept no responsibility for possible errors in catalogues, brochures and other printed material. Danfoss reserves the right to alter its products without notice. This also applies to products already on order provided that such alterations can be made without subsequential changes being necessary in specifications already agreed. All trademarks in this material are property of the respective companies. Danfoss and the Danfoss logotype are trademarks of Danfoss A/S. All rights reserved.