

ML6984, ML7984 Series 4000 Direct Coupled Valve Actuators

PRODUCT DATA



FEATURES

- Self-contained, motorized globe valve linkage.
- Microprocessor-based digital position sensing and motor control for accurate positioning.
- Compact size for easy installation in confined spaces.
- NEMA 3R rain-proof cover for outdoor installation.
- Self-calibrating for valve stroke from 1/2 in. (13 mm) to 1 in. (25 mm).
- DIP switch input configuration selection.
- LED (light-emitting diode) status indication.
- Configurable to 3-wire mode for floating models.
- 710 N 160 lbf (712 N) valve closing force.
- Usable with common transformer power supply for multiple actuators and controllers.
- 24 Vac or 28 Vdc power supply.
- Field-addable position feedback/auxiliary switch module available for 5-wire models.

APPLICATION

The ML6984 and ML7984 are self-contained, self-adjusting, motorized valve actuators that mount directly onto V5011 two-way and V5013 three-way globe valves, providing linear stem operation between 1/2 in. (13 mm) and 1 in. (25 mm).

ML6984 is for use with low voltage SPDT Series 20, Series 60 (on-off), or SP3T Series 60 (floating) electro-mechanical and electronic controllers.

ML7984 is for use with Series 70 0-10 Vdc, 2-10 Vdc, 4-20 mA; electronic Series 90 "SuperMod"; and 135 ohm modulating controllers.

Contents

Specifications	2
Ordering Information	2
Installation	3
Wiring Schematics.....	5
Operation.....	9
Replacement Notes.....	10
Checkout	11
Troubleshooting.....	11



SPECIFICATIONS

IMPORTANT

The specifications given in this publication do not include normal manufacturing tolerances. Therefore, an individual unit may not exactly match the listed specifications. Also, this product is tested and calibrated under closely controlled conditions and some minor differences in performance can be expected if those conditions are changed.

Operating Environment:

Operating Ambient Temperature: 32° to 130° F (0° to 54° C) measured at the actuator.

Shipping Temperature: -40° to 150° F (-40° to +65° C).

Relative Humidity: 15% to 95% up to 104° F (40° C), non-condensing atmosphere NEMA-3R/IP54 cover for outdoor installation.

Acoustic Noise:

55 dBA maximum Sound Pressure Level at 39 in. (991.0 mm) distance.

Electrical Ratings:

Power supply/consumption:

24 V (+10%, -15%), 50/60 Hz or 28 Vdc +/- 10%,
6 VA (Running), 12 VA (Valve seating).

Specifications/CE Declaration:

ML6984 and ML7984 actuators conform to the essential requirements of the Low Voltage Directive 73/23/EEC based on the standards EN 60730-1:2000 and EN 60730-2-14:1995+A1:2001

Inputs:

ML6984 - 25 mA 24 Vac (5-wire mode only)
- 500 mA (valve seating 3-wire mode)
- Minimum Signal Input Duration: 100 ms

ML7984* - 2 -10 Vdc (1 mA); 4-20 mAdc

*May be used with 0-10 Vdc input but valve will be closed at 2 Vdc.

Input Impedance for the ML7984:

Voltage Source — 20 KW ohm
Current Source — 237 ohm

Shipping Weight:

Approx. 2.2 lbs (1 kg).

Accessories/Parts:

272629A - Mounting adapter for V5045 valves.

272630D - Electronic position feedback low voltage auxiliary switch.

272822 - Resistor kit for multiple actuator Series 90 application and for ML7984 to replace the old ML784 (4-20 mA).

272775 - Replacement motor brush kit.

40003793-005 - Mounting hardware bag assembly.

Mechanical Ratings:

Stroke — Between 1/2 in. (13 mm) and 1 in. (25 mm), self-adjusting.

Bonnet — 1 3/8 in. (35 mm) for V5011/13 valves up to 3 in. (76 mm)(DN80).

Stem Coupling — 1/4-28 UNF thread.

Stroke Timing — Nominal 63 seconds for 3/4 in. (19 mm) stroke.

— Proportional to stroke length at 24 Vac.

Closing Force — 710 N (160 lbf) minimum at 24 Vac.

— Force varies 22 N/V (5 lbf/volt).

Performance Specifications:

Life Expectancy — (at rated load and power conditions)
50,000 full stroke cycles plus 1,000,000 repositions of 10% stem travel or 10 years, whichever occurs first.

Hysteresis — 5%

Table 1. Close-off Pressure Ratings for ML6984/7984 Series with Honeywell Globe Valves, psid.

Type	Valve Family	1/2 in.	3/4 in.	1 in.	1-1/4 in.	1-1/2 in.	2 in.	2-1/2 in.	3 in.
Flange	V5011A	--	--	--	--	--	--	33 (228)	19 (131)
	V3350/51; V3450/51	--	--	--	--	--	--	25 (172)	17 (117)
	V5013B, C; V3360/61; V3460/61	--	--	--	--	--	--	25 (172)	17 (117)
NPT	V5011F, G*	150 (1034)	150 (1034)	150 (1034)	150 (1034)	91 (627)	58 (400)	33 (228)	19 (131)
	V5011H, J	150 (1034)	150 (1034)	150 (1034)	150 (1034)	--	--	--	--
	V5011N*, V5013N	230 (1586)	230 (1586)	193 (1331)	123 (848)	79 (545)	44 (303)	--	--
	V5011N2xxx Steam	100 (689)	100 (689)	100 (689)	100 (689)	79 (545)	44 (303)	--	--
	V5011G Steam	100 (689)	100 (689)	100 (689)	100 (689)	91 (627)	58 (400)	33 (228)	19 (131)
	V5013F	150 (1034)	150 (1034)	150 (1034)	149 (1027)	91 (627)	58 (400)	--	--

* Do not exceed 100 psid with valves used in steam applications.

ORDERING INFORMATION

When purchasing replacement and modernization products from your TRADELINE® wholesaler or distributor, refer to the TRADELINE® Catalog or price sheets for complete ordering number.

If you have additional questions, need further information, or would like to comment on our products or services, please write or phone:

1. Your local Honeywell Automation and Control Products Sales Office (check white pages of your phone directory).
2. Honeywell Customer Care
1885 Douglas Drive North
Minneapolis, Minnesota 55422-4386

In Canada—Honeywell Limited/Honeywell Limitée, 35 Dynamic Drive, Toronto, Ontario, M1V 4Z9.

International Sales and Service Offices in all principal cities of the world. Manufacturing in Australia, Canada, Finland, France, Germany, Japan, Mexico, Netherlands, Spain, United Kingdom, U.S.A.

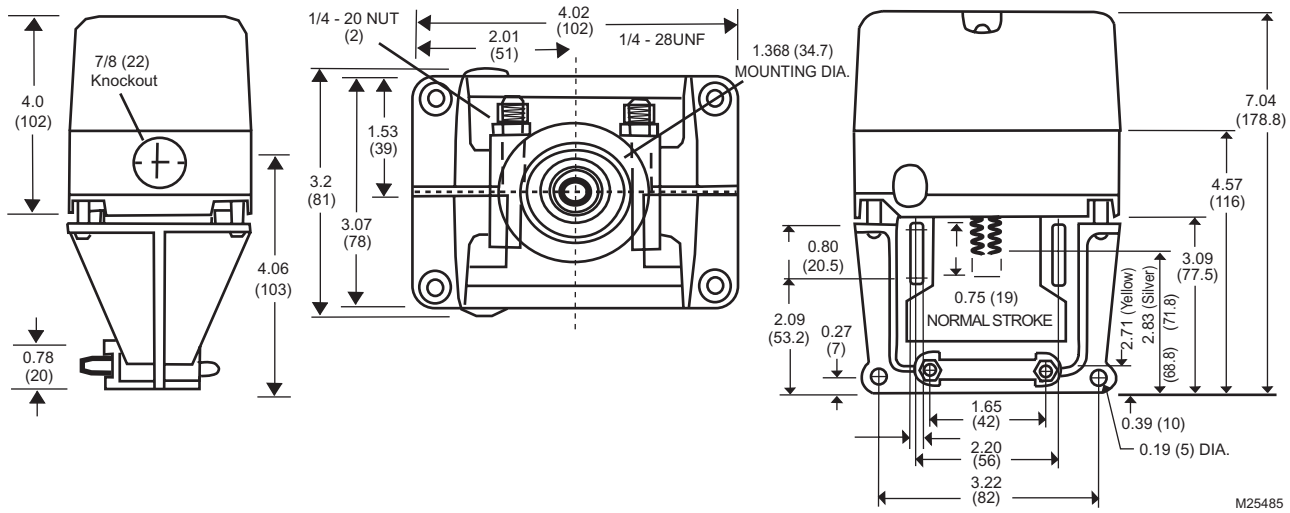

Fig. 1. ML6984 Valve Actuator Dimensions, in. (mm).

INSTALLATION

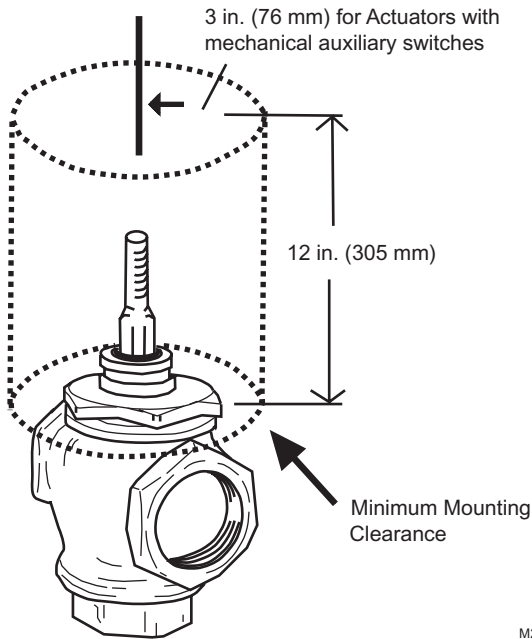

Fig. 2. Minimum Mounting Clearance.

CAUTION

Short and rapid cycling/repositioning may result in possible switch device lock-up or reduced service life.

When Installing This Product...

1. Read these instructions carefully. Failures to follow them could damage the product or cause a hazardous condition.
2. Check ratings given in instructions and on the product to ensure the product is suitable for your application.
3. The installer must be a trained, experienced service technician.
4. After installation is complete, check out product operation as provided in these instructions.
5. DO NOT electrically operate the actuator before assembly to the valve because damage not apparent to the installer may occur.

IMPORTANT

Before installing the valve, raise and lower the valve stem to make sure that the valve stem operates freely. Impaired stem operation can indicate that the stem was bent by rough handling. This condition can require repair or replacement of the valve.

Protect the stem from damage due to bending or scratching. Damage to the stem packing may result.

Proper Use:

Valves are to be installed by skilled personnel and in strict accordance with installation instructions and local regulations. Honeywell assumes no responsibility for damages or injuries resulting from non-compliance with installation instructions or standard good practice when mounting, operating, or maintaining the valves, even if not explicitly mentioned in the installation instructions. Observe all safety practices when working with steam systems.

Mounting:

1. Ensure that valve body is installed correctly, arrow pointing in the direction of flow.
2. Actuator can be mounted in any position; however, it is preferable that it is mounted above the horizontal plane of the pipe. This minimizes the risk of damage to the actuator in the event of condensation or valve gland leak. When controlling steam, rotate the valve body with the actuator beside the valve to avoid exceeding ambient temperature limits of the actuator. For the same reason, do not mount ML Actuators to steam valves in enclosed cabinets. For on-off control of steam in small pipe sizes, Honeywell recommends V8043J zone valves.

NOTE: NEMA 3R rainproof rating only applies to actuators mounted vertically. Cover has been treated with UV stabilizers for outdoor applications. Weather-proof conduit fittings approved for outdoor and wet locations must be used to maintain NEMA 3R rating.

3. Remove stem button (Fig. 3) from valve stem.
4. (Optional) Snap red position indicator (metal clip) over valve stem and position for best visibility (Fig. 3). Indicator will self-align to the marking on yoke after complete operating cycle. It is recommended that this is done after actuator installation.

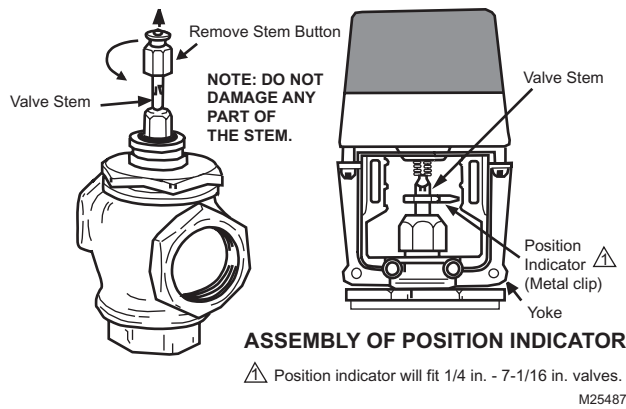

Fig. 3. Preparation for Valve Assembly.

Assembly of MLx984 Actuator to the Valve:

1. The drive shaft of the MLx984 Actuator has a 1/4-28 UNF threaded hole to link with the valve stem. Slide the yoke over the valve bonnet (Fig. 4).
2. Thread the MLx984 Actuator drive shaft onto the valve stem all the way, until it is completely attached (with no threads showing), by turning the valve actuator in a clockwise direction, as viewed from above. Depending on the valve body, use a pin or wrench to keep valve stem from turning. Note that the valve actuator is shipped with drive shaft in the mid-position.
3. Care should be exercised when using tools on the valve stem during tightening (Fig. 4). DO NOT damage the threads or other parts of the stem.
4. Orient the conduit hole to the most desirable direction, then tighten the LOCKNUTS on the U-bolt.
5. Remove the plastic cover from the MLx984 by loosening the two captive screws located on the top. Drop the Allen (Hex) type of set screw (included in the plastic bag) into the top of the shaft, hex side up.
6. **Tighten the set screw to lock valve stem in place** (Fig. 6), using a 1/8 in. Allen wrench (included).

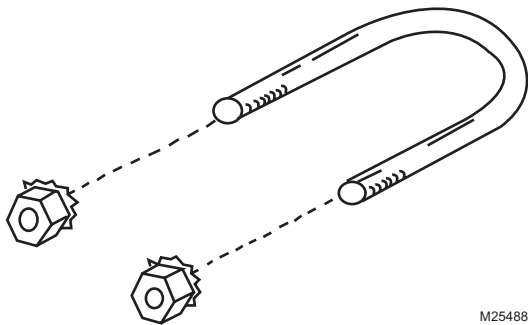
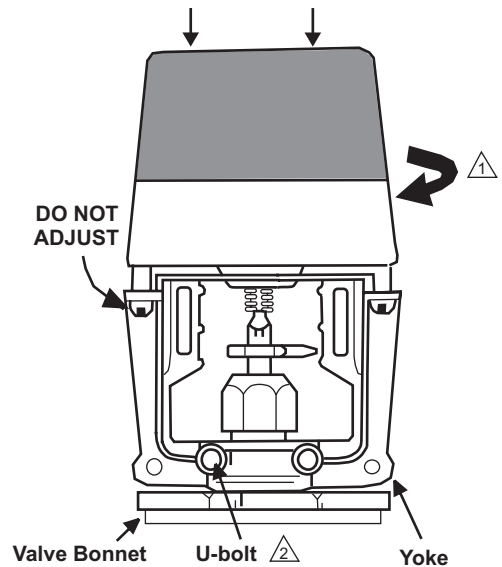

Fig. 4. U-bolt Assembly.

NOTE: Use U-bolt supplied with actuator. Do not replace with stainless steel U-bolt on chilled water valves. Condensation may cause corrosion of yoke with SS U-bolt.



- ⚠️ THREAD ACTUATOR SHAFT TO VALVE STEM BY ROTATING IN A CLOCKWISE DIRECTION.
- ⚠️ TIGHTEN U-BOLT NUTS TO SECURE LINKAGE TO VALVE BODY.

Fig. 5. Assembly of MLx984A to Valve.

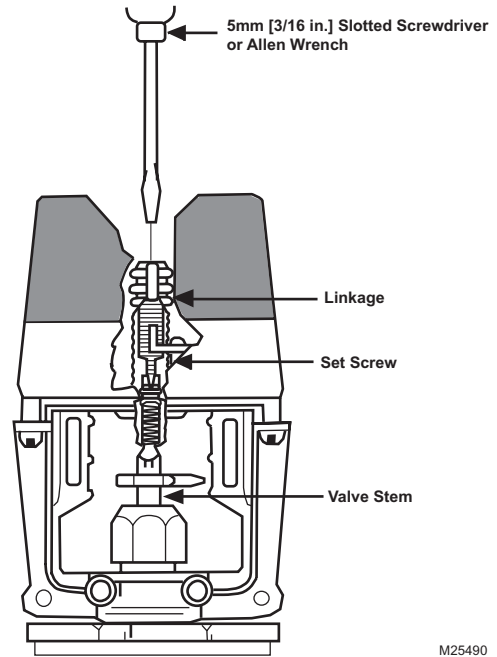

Fig. 6. Locking MLx984A Drive Shaft to Valve Stem.



CAUTION

For proper valve operation, valve stem must be threaded into the actuator all the way (with no threads showing) and locked in place with the set screw provided.

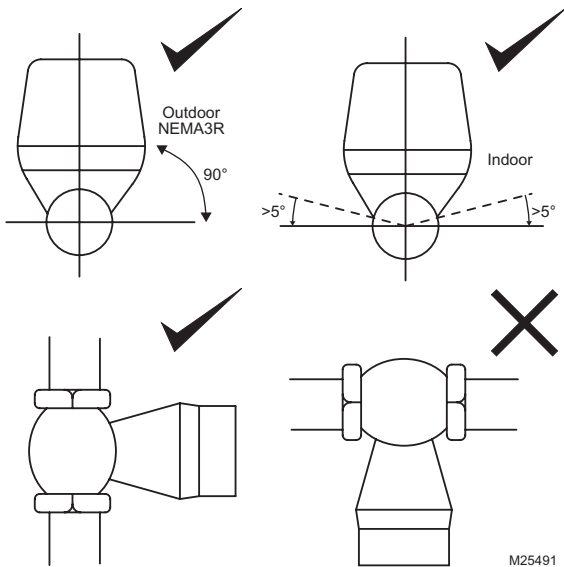

Fig. 7. Mounting Positions.

WIRING SCHEMATICS

MLx984 actuators are designed to operate from a Safety Extra Low Voltage, Class II power source. A 7/8 in. (22 mm) wiring hole is provided for attaching flexible conduit where required by local codes. When installing outdoors, weatherproof conduit fittings approved for outdoor and wet locations must be used.

CAUTION

Electrical Shock or Equipment Damage Hazard. Can Shock Individuals or Short Equipment Circuitry. Disconnect power supply to the actuator to prevent electrical shock and equipment damage, or remove and cap the air line to the actuator.

NOTE: In all cases when wiring multiple actuators, the power supply to all actuators must be connected in a “star” fashion to reduce excessive voltage drop. DO NOT “daisy chain” i.e. connect power to one actuator then branch to another.

Operation:

The recommended valve actuator power source is a Safety Extra-Low Voltage (SELV) Class II, 24 V transformer or regulated 28 Vdc across terminals T5 and T6. Internal circuitry provides dc power for the electronic sensing and drive motor circuits.

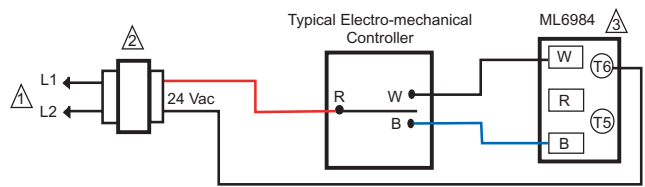

- ⚠ POWER SUPPLY PROVIDES OVERLOAD PROTECTION AND DISCONNECT MEANS.
- ⚠ ALLOW UP TO 0.5 AMPS FOR EACH DEVICE. ACTUATORS AND CONTROLLER CAN SHARE SAME TRANSFORMER, PROVIDED THAT THE VA RATING OF THE TRANSFORMER IS NOT EXCEEDED AND PROPER PHASING IS OBSERVED. DO NOT MIX A.C. AND D.C. POWER SOURCES.
- ⚠ CONTROLLER CAN BE LOW VOLTAGE SPDT SERIES 20 “ON-OFF” OR SP3T SERIES 60 “FLOATING” (TRI-STATE) TYPE. TERMINALS R AND T5 ARE CONNECTED INSIDE THE ML6984.

Fig. 8. 3-Wire Control of ML6984 with Series 60 Controller.

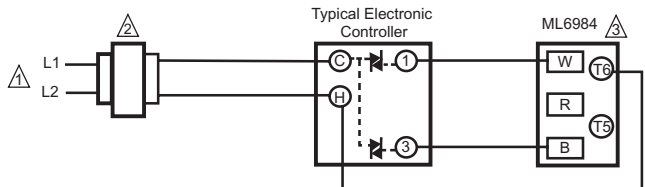

- ⚠ POWER SUPPLY PROVIDES OVERLOAD PROTECTION AND DISCONNECT MEANS.
- ⚠ ALLOW UP TO 0.5 AMPS FOR EACH DEVICE. ACTUATORS AND CONTROLLER CAN SHARE SAME TRANSFORMER, PROVIDED THAT THE VA RATING OF THE TRANSFORMER IS NOT EXCEEDED AND PROPER PHASING IS OBSERVED. DO NOT MIX A.C. AND D.C. POWER SOURCES.
- ⚠ CONTROLLER CAN BE LOW VOLTAGE SPDT SERIES 20 “ON-OFF” OR SP3T SERIES 60 “FLOATING” (TRI-STATE) TYPE. TERMINALS R AND T5 ARE CONNECTED INSIDE THE ML6984.

Fig. 9. 3-Wire Control of ML6984 with Electronic Controller.

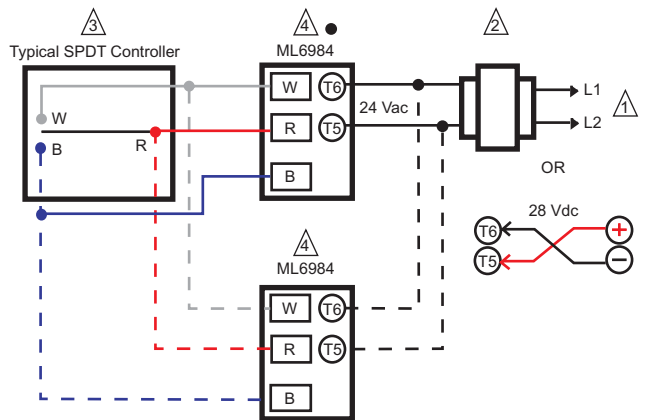

- ⚠ POWER SUPPLY PROVIDES OVERLOAD PROTECTION AND DISCONNECT MEANS.
- ⚠ ALLOW UP TO 0.5 AMPS FOR EACH DEVICE. ACTUATORS AND CONTROLLER CAN SHARE SAME TRANSFORMER, PROVIDED THAT THE VA RATING OF THE TRANSFORMER IS NOT EXCEEDED AND PROPER PHASING IS OBSERVED. DO NOT MIX A.C. AND D.C. POWER SOURCES.
- ⚠ CONTROLLER CAN BE LOW VOLTAGE SPDT SERIES 20 “ON-OFF” OR SP3T SERIES 60 “FLOATING” (TRI-STATE) TYPE. TERMINALS R AND T5 ARE CONNECTED INSIDE THE ML6984.
- ⚠ MULTIPLE ACTUATORS CONTROLLED BY A COMMON CONTROLLER IN PARALLEL MUST BE WIRED SO THAT THEY ALL TRAVEL IN THE SAME DIRECTION. REVERSE ACTING ACTUATORS WILL NOT OPERATE RELIABLY IN COMBINATION WITH DIRECT ACTING UNITS DUE TO GEARBOX TOLERANCES. USE ML7984 MODULATING ACTUATORS, OR DEDICATED CONTROLLERS, OR SEPARATE CONTROLLER OUTPUTS FOR EACH GROUP INSTEAD.

Fig. 10. 5-Wire Control of ML6984.

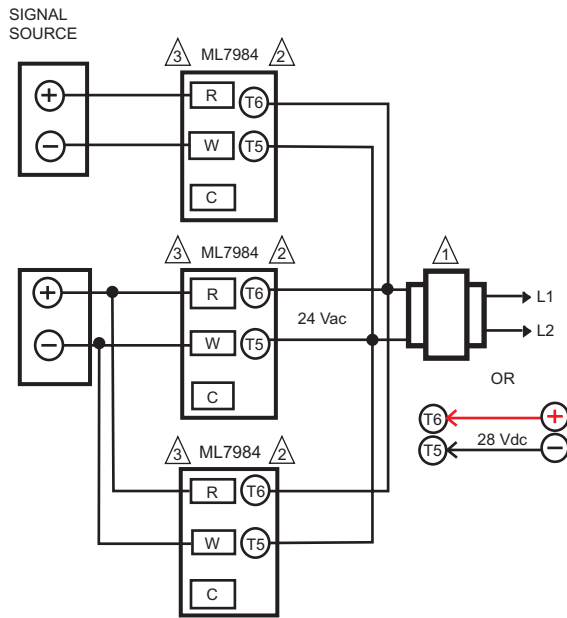

FUNCTION	DIP SWITCH CONFIGURATION								
1000 2-10 Vdc Direct Acting	<table border="1"> <tr> <td>On (1)</td> <td>Off (0)</td> <td>On (1)</td> <td>Off (0)</td> </tr> <tr> <td>1</td> <td>2</td> <td>3</td> <td>4</td> </tr> </table>	On (1)	Off (0)	On (1)	Off (0)	1	2	3	4
On (1)	Off (0)	On (1)	Off (0)						
1	2	3	4						
1010 10-2 Vdc Reverse Acting	<table border="1"> <tr> <td>On (1)</td> <td>Off (0)</td> <td>On (1)</td> <td>Off (0)</td> </tr> <tr> <td>1</td> <td>2</td> <td>3</td> <td>4</td> </tr> </table>	On (1)	Off (0)	On (1)	Off (0)	1	2	3	4
On (1)	Off (0)	On (1)	Off (0)						
1	2	3	4						

- ⚠ POWER SUPPLY PROVIDES OVERLOAD PROTECTION AND DISCONNECT MEANS.
- ⚠ ALLOW UP TO 0.5 AMPS FOR EACH DEVICE. ACTUATORS AND CONTROLLER CAN SHARE SAME TRANSFORMER PROVIDING THE VA RATING OF THE TRANSFORMER IS NOT EXCEEDED AND PROPER PHASING IS OBSERVED. DO NOT MIX A.C. AND D.C. POWER SOURCES.
- ⚠ IN ML7984, "T5" AND "W" TERMINALS ARE CONNECTED INTERNALLY. DEVICE IS COMPATIBLE WITH 3 CONDUCTOR WIRING.
- ⚠ USE CONFIGURATION DIP SWITCHES TO SELECT DEVICE FUNCTIONS: DIRECT ACTING FUNCTION (ACTUATOR STEM MOVES DOWNWARDS WITH SIGNAL INCREASES TO 10V/20MA) OR REVERSE ACTING FUNCTION (ACTUATOR STEM MOVES UPWARDS WITH SIGNAL INCREASES TO 10V/20MA).
- ⚠ ALWAYS TURN POWER OFF BEFORE SETTING ANY DIP SWITCHES.

M25495

Fig. 11. ML7984 Wiring with 10 Vdc Analog Control Signal.

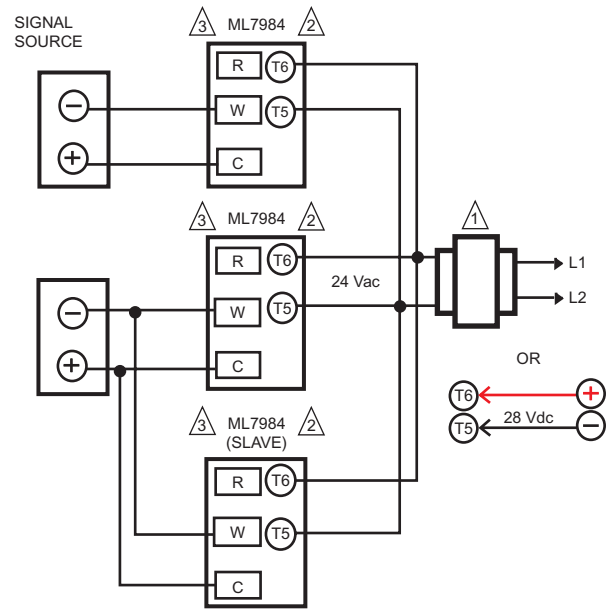

FUNCTION	DIP SWITCH CONFIGURATION								
X000 4-20 mA Direct Acting	<table border="1"> <tr> <td>Master actuator →</td> <td>← Slave actuator</td> <td>On (1)</td> <td>Off (0)</td> </tr> <tr> <td>1</td> <td>2</td> <td>3</td> <td>4</td> </tr> </table>	Master actuator →	← Slave actuator	On (1)	Off (0)	1	2	3	4
Master actuator →	← Slave actuator	On (1)	Off (0)						
1	2	3	4						
X010 20-4 mA Reverse Acting	<table border="1"> <tr> <td>Master actuator →</td> <td>← Slave actuator</td> <td>On (1)</td> <td>Off (0)</td> </tr> <tr> <td>1</td> <td>2</td> <td>3</td> <td>4</td> </tr> </table>	Master actuator →	← Slave actuator	On (1)	Off (0)	1	2	3	4
Master actuator →	← Slave actuator	On (1)	Off (0)						
1	2	3	4						

- ⚠ POWER SUPPLY PROVIDES OVERLOAD PROTECTION AND DISCONNECT MEANS.
- ⚠ ALLOW UP TO 0.5 AMPS FOR EACH DEVICE. ACTUATORS AND CONTROLLER CAN SHARE SAME TRANSFORMER PROVIDING THE VA RATING OF THE TRANSFORMER IS NOT EXCEEDED AND PROPER PHASING IS OBSERVED. DO NOT MIX A.C. AND D.C. POWER SOURCES.
- ⚠ IN ML7984, "T5" AND "W" TERMINALS ARE CONNECTED INTERNALLY. DEVICE IS COMPATIBLE WITH 3 CONDUCTOR WIRING.
- ⚠ USE CONFIGURATION DIP SWITCHES TO SELECT DEVICE FUNCTIONS: DIRECT ACTING FUNCTION (ACTUATOR STEM MOVES DOWNWARDS WITH SIGNAL INCREASES TO 10V/20MA) OR REVERSE ACTING FUNCTION (ACTUATOR STEM MOVES UPWARDS WITH SIGNAL INCREASES TO 10V/20MA).
- ⚠ ALWAYS TURN POWER OFF BEFORE SETTING ANY DIP SWITCHES.

M25496

Fig. 12. ML7984 Wiring with 20mA Analog Control Signal.

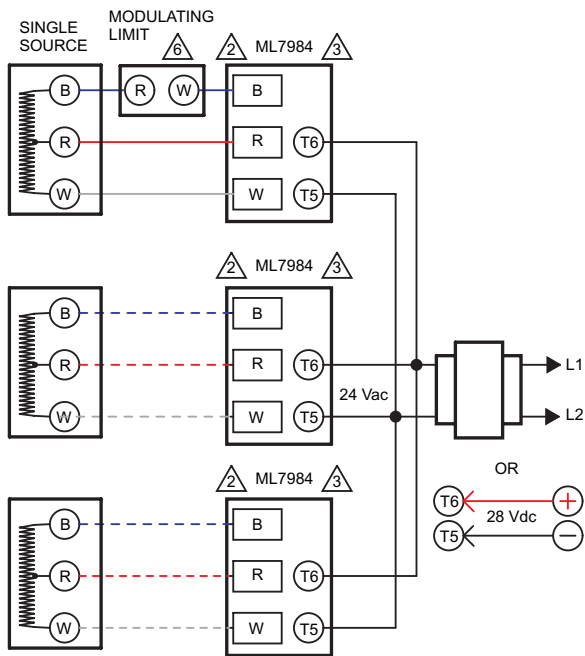

FUNCTION	DIP SWITCH CONFIGURATION				
1001 Mechanical Series 90 Direct Acting					On (1) Off (0)
1011 Mechanical Series 90 Reverse Acting					On (1) Off (0)

- ⚠ POWER SUPPLY PROVIDES OVERLOAD PROTECTION AND DISCONNECT MEANS.
- ⚠ ALLOW UP TO 0.5 AMPS FOR EACH DEVICE. ACTUATORS AND CONTROLLER CAN SHARE SAME TRANSFORMER PROVIDING THE VA RATING OF THE TRANSFORMER IS NOT EXCEEDED AND PROPER PHASING IS OBSERVED. DO NOT MIX A.C. AND D.C. POWER SOURCES.
- ⚠ DO NOT MIX M984/6 OR MODUTROL MOTORS WITH THE ML7984 IN THE SAME CIRCUITRY.
- ⚠ USE CONFIGURATION DIP SWITCHES TO SELECT DEVICE FUNCTIONS: DIRECT ACTING FUNCTION (ACTUATOR STEM MOVES UPWARDS WITH SIGNAL INCREASE) OR REVERSE ACTING FUNCTION (ACTUATOR STEM MOVES DOWNWARDS WITH SIGNAL INCREASE).
- ⚠ TURN POWER OFF BEFORE SETTING ANY DIP SWITCHES. FOR COMMON TRANSFORMER AND COMMON CONTROLLER APPLICATION, PLEASE CONSULT THE FACTORY.
- ⚠ MAXIMUM RESISTANCE PER CONTROL CIRCUIT OF 280 OHM.

Fig. 13. ML7984 Wiring with Common Transformer, Individual Controllers.

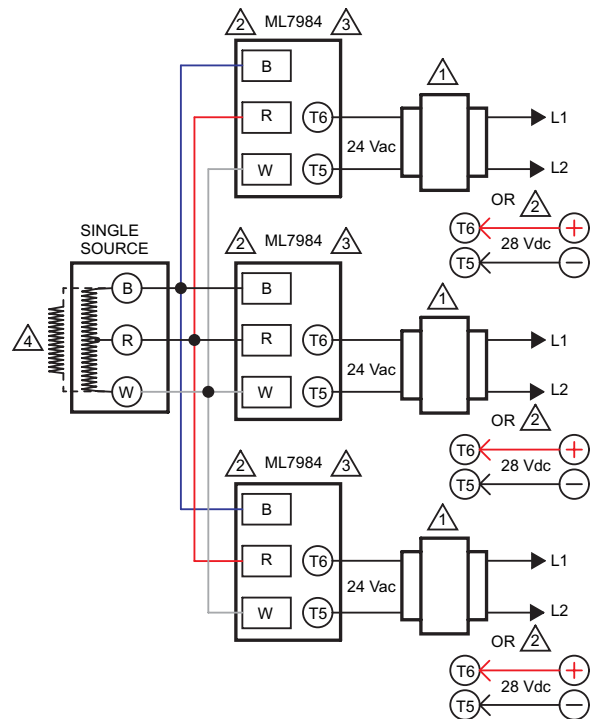

RESISTOR SELECTION CHART		
NO. OF ACTUATORS	RESISTOR VALUE	
1	RESISTOR NOT REQ'D.	
2	133 OHM	ALL RESISTORS 1/4 WATT 1% METAL FILM
3	68.1 OHM	
4	45.3 OHM	

- ⚠ POWER SUPPLY PROVIDES OVERLOAD PROTECTION AND DISCONNECT MEANS.
- ⚠ ALLOW UP TO 0.5 AMPS FOR EACH DEVICE. ACTUATORS AND CONTROLLER CAN SHARE SAME TRANSFORMER PROVIDING THE VA RATING OF THE TRANSFORMER IS NOT EXCEEDED AND PROPER PHASING IS OBSERVED. DO NOT MIX A.C. AND D.C. POWER SOURCES.
- ⚠ DO NOT MIX M984/6 OR MODUTROL MOTORS WITH THE ML7984 IN THE SAME CIRCUITRY.
- ⚠ USE RESISTOR KIT PART NUMBER 272822.

Fig. 14. ML7984 with Individual Transformers, Common Controller.

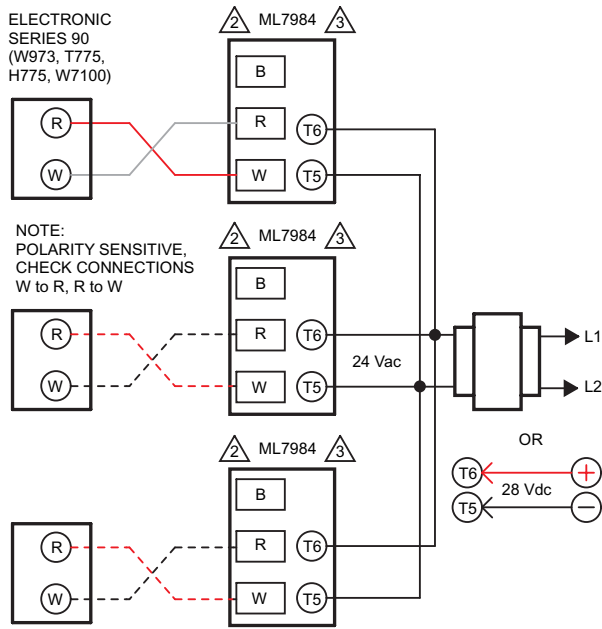

FUNCTION	DIP SWITCH CONFIGURATION
1101 Electronic Series 90 Direct Acting	 On (1) Off (0)
1111 Electronic Series 90 Reverse Acting	 On (1) Off (0)

- ⚠️ POWER SUPPLY PROVIDES OVERLOAD PROTECTION AND DISCONNECT MEANS.
- ⚠️ ALLOW UP TO 0.5 AMPS FOR EACH DEVICE. ACTUATORS AND CONTROLLER CAN SHARE SAME TRANSFORMER PROVIDING THE VA RATING OF THE TRANSFORMER IS NOT EXCEEDED AND PROPER PHASING IS OBSERVED. DO NOT MIX A.C. AND D.C. POWER SOURCES.
- ⚠️ DO NOT MIX M984/6 OR MODUTROL MOTORS WITH THE ML7984 IN THE SAME CIRCUITRY.
- ⚠️ USE CONFIGURATION DIP SWITCHES TO SELECT DEVICE FUNCTIONS: DIRECT ACTING FUNCTION (ACTUATOR STEM MOVES UPWARDS WITH SIGNAL INCREASES TO 10V/20MA) OR REVERSE ACTING FUNCTION (ACTUATOR STEM MOVES DOWNWARDS WITH SIGNAL INCREASES TO 10V/20MA).
- ⚠️ TURN POWER OFF BEFORE SETTING ANY DIP SWITCHES. M25499

Fig. 15. ML7984 with Common Transformer, Individual Controllers.

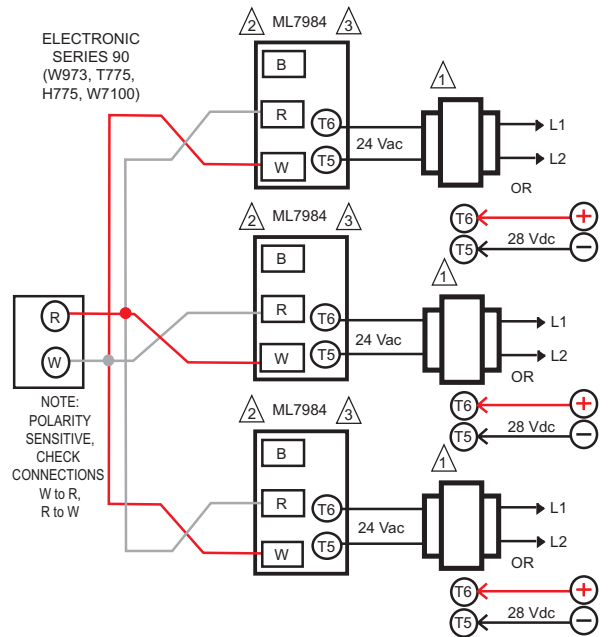

FUNCTION	DIP SWITCH CONFIGURATION
1101 Electronic Series 90 Direct Acting	 On (1) Off (0)
1111 Electronic Series 90 Reverse Acting	 On (1) Off (0)

- ⚠️ POWER SUPPLY PROVIDES OVERLOAD PROTECTION AND DISCONNECT MEANS.
- ⚠️ ALLOW UP TO 0.5 AMPS FOR EACH DEVICE. ACTUATORS AND CONTROLLER CAN SHARE SAME TRANSFORMER PROVIDING THE VA RATING OF THE TRANSFORMER IS NOT EXCEEDED AND PROPER PHASING IS OBSERVED. DO NOT MIX A.C. AND D.C. POWER SOURCES.
- ⚠️ DO NOT MIX M984/6 OR MODUTROL MOTORS WITH THE ML7984 IN THE SAME CIRCUITRY.
- ⚠️ USE CONFIGURATION DIP SWITCHES TO SELECT DEVICE FUNCTIONS: DIRECT ACTING FUNCTION (ACTUATOR STEM MOVES UPWARDS WITH SIGNAL INCREASES TO 10V/20MA) OR REVERSE ACTING FUNCTION (ACTUATOR STEM MOVES DOWNWARDS WITH SIGNAL INCREASES TO 10V/20MA).
- ⚠️ TURN POWER OFF BEFORE SETTING ANY DIP SWITCHES. M25500

Fig. 16. ML7984 with Individual Transformers, Common Controller.

OPERATION

Each time actuator terminals T5 and T6 are (re)powered, the microprocessor will cycle the valve through a full stroke to calibrate its position. Any stroke between 1/2 in. (13 mm) and 1 in. (25 mm) will be divided into 30 equal steps. Run time is proportional to stroke length and power supply voltage. The actuator will also slow down as the valve closes off the seat. The LED lights when terminals T5 and T6 are powered, and flashes when the actuator is in motion. T5 is connected to Terminal R in ML6984 and to Terminal W in ML7984.

NOTE: Initial callibration does not apply to ML6984 installed for 3-wire control or installed for 5-wire control without the 272630D position feedback/auxiliary switch module. Span and start positions will need to be set during controller set-up. See ML6984 Operation 3-wire, below. ML7984 always conducts a self-calibration sequence when (re)powering up.

ML7984 Operation:

The microprocessor responds to the signal across the input terminals based on the configuration DIP switch settings.

When correctly connected to the actuator, a control signal between signal input terminals is converted to a digital run time and compared to pulse counts from the first gear in the gear train. When these counters are equal, the drive motor and drive shaft are stationary.

As long as the value of the controlled medium remains at the controller setpoint, the control loop circuit is in balance, and the actuator does not run. When the controller set point or controlled temperature changes, the controller output voltage is changed, causing the counters to differ. As the actuator moves in the direction to correct the difference, the counters increment or decrement, and stop the actuator when the input and gear counts agree.

At the end of the valve stroke, the actuator develops the necessary force for positive valve close-off. The motor stops automatically when the motor draws a predetermined current which corresponds to a force level. The digital counters are reset and calibrated at each end of stroke.

Modulating actuators will automatically travel to the position corresponding to analog input signal following the self-calibration cycle.



CAUTION

Disconnect power supply before beginning installation to prevent electrical shock and equipment damage.

All wiring must comply with applicable local electrical codes, ordinances, and regulations.

Make certain that the voltage and frequency of the power supply correspond to the rating of the device.

DO NOT electrically operate the MLx984 actuator before assembly to the valve because damage not apparent to the installer may occur.

DO NOT connect 24 Vac between any ML7984 signal input terminals. DEVICE FAILURE WILL RESULT.

NOTE:

1. The ML7984 must be field configured with the DIP switches which are located beside the terminal block. See wiring diagrams for details. Turn power off before setting any DIP switches.
2. There is a 1.5 second delay in actuator response to every signal change. This occurs to screen out electrical noise.
3. For proper operation, voltage on the T5 and T6 must not be less than 22 Vac or 24 Vdc during running or force generating stages. Increase transformer VA rating or use a model with better regulation if voltage drops below 22 Vac when the valve is closing off.

ML6984 Floating Operation, 5-Wire:

The motor is controlled by a microprocessor. Connecting B to R for 1/10 second or longer tells the microprocessor to cause the actuator to drive upwards. Connecting W to R will cause the actuator to drive downwards. For "floating" control, the actuator will remain in the last position when there is no connection to R.

At the end of the valve stroke, the actuator will develop the necessary force for positive valve close-off. As forces are developed, the current to the motor increases. The microprocessor stops the actuator automatically when motor current and force reaches the factory-calibrated level.

NOTE: There must be at least 1.5 second delay between successive floating input signals. The actuator will ignore floating signals during calibration cycle and does not remember any pulses sent during this period. The controller may need to run through its own calibration cycle before use.

ML6984 Operation, 3-Wire:

ML6984 may be installed like a conventional (non-electronic) floating actuator. The interface electronics are powered at the same time as the motor. Pulses must be at least 100 ms long with a delay of at least 1500 ms between pulses. When ML6984 is not powered between terminals T6 and T5/R, self-calibration will not occur. The controller must drive the valve through a cycle manually to calibrate stroke to the controller.

NOTE: The 272630D position feedback/auxiliary switch module cannot be used with ML6984 3-wire installation. The 272630D requires continuous power.

ML6984 XL10 Controller Compatibility:

XL10 controllers are designed to work with constant-speed actuators. ML6984 actuators use direct current motors which vary their speed as the valve seats or if power supply voltage is not consistent. ML6984 actuators in 5-wire mode offer 30 discrete positions only. To minimize potential valve position drift, XL10 controllers should use the 3-wire installation and be programmed for a daily valve exercise cycle.

ML6984 On-Off Operation:

For on-off operation, ML6984 requires a 24 Vac SPDT contact. An interface relay such as RA889 is required to power the anticipator heater of an electromechanical thermostat such as T87F (See Fig. 17).

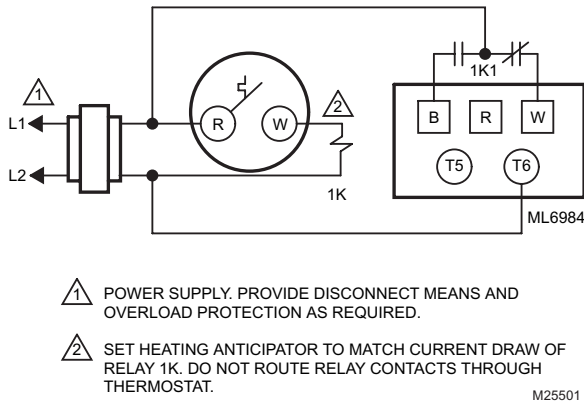

- 1 POWER SUPPLY. PROVIDE DISCONNECT MEANS AND OVERLOAD PROTECTION AS REQUIRED.
- 2 SET HEATING ANTICIPATOR TO MATCH CURRENT DRAW OF RELAY 1K. DO NOT ROUTE RELAY CONTACTS THROUGH THERMOSTAT.

Fig. 17. ML6984 with Honeywell T87F Round™ Thermostat.

If connecting the ML6984 directly to a T87F with a Series 20 sub-base, clip out the cooling anticipation resistor on the sub-base between terminals R and Y. This is needed for electrical compatibility with ML6984 but may result in wider room temperature swings due to the loss of anticipation.

REPLACEMENT NOTES

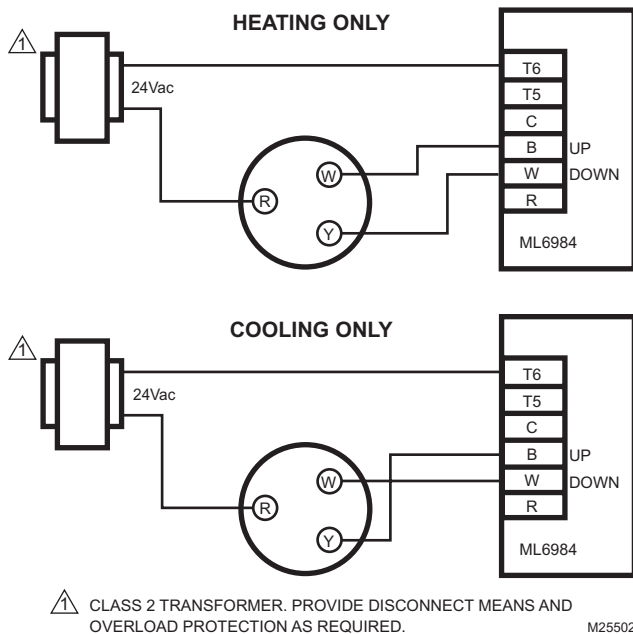

- 1 CLASS 2 TRANSFORMER. PROVIDE DISCONNECT MEANS AND OVERLOAD PROTECTION AS REQUIRED.

Fig. 18. ML6984 with Honeywell T87K Round™ Thermostat.

See Fig. 19, if connecting TH5110D or TH6110D FocusPRO™ thermostats to ML6984. Configure the thermostats for Series 20 operation.

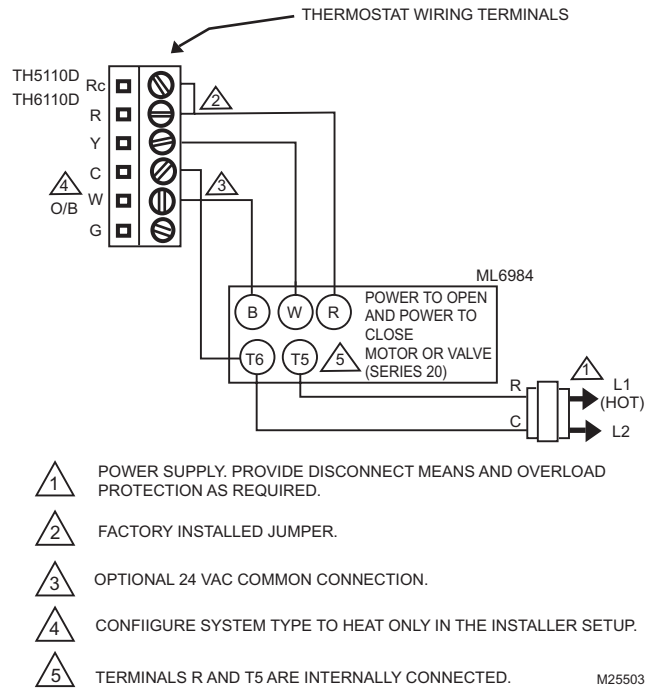

- 1 POWER SUPPLY. PROVIDE DISCONNECT MEANS AND OVERLOAD PROTECTION AS REQUIRED.
- 2 FACTORY INSTALLED JUMPER.
- 3 OPTIONAL 24 VAC COMMON CONNECTION.
- 4 CONFIGURE SYSTEM TYPE TO HEAT ONLY IN THE INSTALLER SETUP.
- 5 TERMINALS R AND T5 ARE INTERNALLY CONNECTED.

Fig. 19. ML6984 with FocusPro™ Electronic Thermostat.

To Replace ML784 or ML984:

1. The old ML784 or ML984 actuators cannot be used with new ML7984 valve actuators in the same circuitry, unless the old models are each powered by their own transformer to prevent cross-talking.
2. The ML7984 is a direct replacement for all old ML784 and ML984, except:
 - a. When replacing the old reverse acting models, the signal input wires to the new devices no longer need to be reversed. Just follow the terminal polarity designations and DIP switch settings.
 - b. When replacing the old actuator which has an Electronic Series 90 "Supermod" controller - e.g.: T775, W973, H775, W7100 - the old interface resistor must be removed. The ML7984 Series 4000 will work directly with the controller without the external 240 ohm resistor.
 - c. When replacing the old ML784 (mA model) in multiple-actuator installations, resistor(s) will be needed. Use Resistor Kit (part no. 272822) and set DIP switches accordingly. See Figures 17 and 18.

To Replace ML684A:

1. The new ML6984 is a direct replacement for the old ML684A in single actuator or parallel multiple actuators hook-up. The old and new actuators can be mixed in the same electrical circuit. For multiple actuators controlled by a common controller in parallel, these actuators must be wired so that they all travel in the same direction.
2. When replacing the ML684A1009 (80 lbf) with this new ML6984 on the V5045 valve, the installed valve adaptor (part no. 272629A) on the valve stem and actuator assembly is still needed.

NOTE: The 272630D position feedback/auxiliary switch module cannot be used with ML6984 3-wire installation. The 272630D requires continuous power.

To Replace ML6874:

1. The ML6984 is a direct replacement for the old ML6874 in single actuator hook-up.
2. For parallel, multiple ML6874 actuators applications, an isolation relay must be used. The isolation relay contacts should be placed in the new ML6984 actuator signal input "W" and "B" circuit.

To Replace Line Voltage Auxiliary Switches:

These accessories are no longer available. Replace the old actuator with new model and 272630D position feedback/auxiliary switch module.

Operate an external relay, such as R8845U, using the adjustable SPDT pilot duty output on the 272630D.

If a second, independent output switch is needed, wire the 2-10 Vdc position feedback signal to an Approved, adjustable, voltage-controlled relay.

CHECKOUT

ML7984:

1. Make sure the valve stem is completely screwed into the actuator drive shaft with no threads showing before applying power.
2. Make sure the valve stem is locked in place with the set screw.
3. Make sure the Configuration DIP switches are set correctly.
4. With 24 Vac or 28 Vdc power source connected to T5 and T6, actuator operation can be verified by connecting appropriate control signal (Series 70/90) from controller to the signal input terminals (Figures 8 thru 16). For direct acting: A modulating action can be obtained by increasing the control signal. The actuator will travel from stem down to stem up. On signal failure (disconnected/no signal), actuator defaults to closed position. For reverse acting: Decreasing controller signal will drive actuator from full stem down to full stem up. On signal failure (disconnect/no signal), actuator defaults to open position.

5. Operate the system (valve, actuator, and controller) for several cycles to ensure proper installation.
6. When checkout is complete, return the controller to the desired setting.

NOTE:

1. Device will ignore any input changes until it has completed its repositioning relative to the initial signal input.
2. 272630D position feedback/auxiliary switch module is inactive during self-calibration.

ML6984: 5-Wire Installation:

1. Make sure the valve stem is completely screwed into the actuator drive shaft with no threads showing before applying power.
2. Make sure the valve stem is locked in place with the set screw.
3. Connect 24 Vac or 28 Vdc power to T5 and T6.
4. Jumper R and B. The valve stem should move up.
5. Jumper R and W. The valve stem should move down.
6. For Floating operation, open R connection Valve stem should remain in position.
7. Re-connect all control wiring.
8. Operate the system (valve, actuator, and controller) for several cycles to ensure proper installation.
9. When checkout is complete, return the controller to the desired setting.

ML6984: 3-Wire Installation:

1. Make sure the valve stem is completely screwed into the actuator drive shaft with no threads showing before applying power.
2. Make sure the valve stem is locked in place with the set screw.
3. Connect 24 Vac to T6.
4. Manually override the controller to signal the actuator to open/close for a few cycles to ensure proper installation.
5. When checkout is complete, return the controller to the desired setting.

TROUBLESHOOTING

SYMPTOM	POSSIBLE CAUSES	ACTIONS
Valve seat leaks or will not close properly	Wrong actuator used and/or system head pressure too high	1) Check valve close-off rating 2) Check voltage at actuator terminals
	Actuator not properly installed	Ensure valve stem is fully threaded into brass drive shaft and locked in place with the set screw
	Incorrect DIP switch settings	Check against Product Instruction Sheet
Noisy motor	Bearing failed due to overheat	1) Check for excessive temperature and replace complete actuator 2) Use high temperature kit (43196000-001)
	Brushes worn out	Check for excessive cycling and replace actuator or brushes (part no. 272775)

SYMPTOM	POSSIBLE CAUSES	ACTIONS
Motor overheats/smoke/component burn-out	Current sensing circuit failed or electronic components failed	Replace actuator. Make sure: 1) Correct actuator used 2) Properly installed 3) Do not operate actuator before mounting on valve supply 4) Proper voltage supply
ML will not respond	LED (on):	
	Incorrect DIP switch settings	Check against Product Instruction Sheet
	No control signal present	Check controller
	Incorrect wiring connections	Check against Product Instruction Sheet
	Internal time delay	Allow at least 1/2 - 1 second for the ML to respond
	LED (off):	
	No or low power supply	Check voltage on T5 and T6 terminals
	Error mode (gearbox damage)	1) Check power supply 2) Check calibration cycle 3) Valve stroke length less than 1/2 in. or greater than 1 1/4 in. 4) Reset device by a momentary disconnect of power at T5 and T6
Vdc/mA signal drops when connected to ML	ML7984 in mA mode with voltage input	Change DIP switch setting
	Signal degradation due to incompatible load impedance	Output and ML input impedance specifications
Actuator yoke corrodes	Galvanic reaction from dissimilar metals if SS U-bolt used with aluminum yoke	Replace U-bolt with galvanized U-bolt and nuts
Floating Actuator position "drifts" when used with building automation system	Mismatch between actuator resolution (30 steps) and BAS controller	1) Read actual valve position using 272630D feedback module 2) Rewire actuator for 3-wire control 3) Program daily valve reset

TYPICAL SPECIFICATIONS

Valve Actuators shall mount directly to the bonnet of the valve, and shall be self-contained and self adjusting.

Direct coupled valve actuators shall be 24° Vac or 28° Vdc power, available with floating or modulating control signal inputs. Actuator shall be usable with common power supply for multiple actuators and controllers.

Position feedback voltage/pilot duty auxiliary switch kit, mounting adaptor, high temperature kits, and resistor kits for multiple actuator application shall be optional accessories for direct coupled valve actuators.

Direct coupled valve actuators shall have a minimum performance rating of 50,000 full stroke cycles plus 1,000,000 repositions documented in the product literature.

Direct coupled valve actuators shall be manufactured by the same company as manufactures the valves.

Automation and Control Solutions

Honeywell International Inc.

1985 Douglas Drive North

Golden Valley, MN 55422

customer.honeywell.com

© U.S. Registered Trademark

© 2008 Honeywell International Inc.

95C-10939—6 J.I. Rev. 04-08

Honeywell Limited-Honeywell Limitée

35 Dynamic Drive

Toronto, Ontario M1V 4Z9

Honeywell



Printed in U.S.A. on recycled paper containing at least 10% post-consumer paper fibers.