

# M400

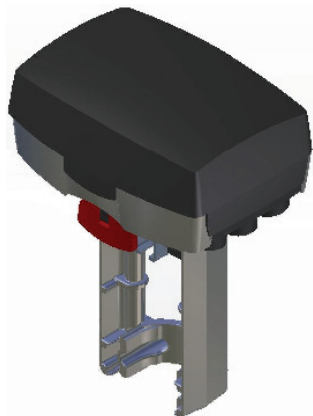

## SPECIFICATIONS

Part numbers . . . . . see the table on the next page  
 Supply voltage . . . 24 V AC +25%/ -35%, 50–60 Hz  
 Power consumption . . . . . average 6 VA  
 Transformer sizing . . . . . 30 VA

### Running time

Modulating . . . . . 60 s  
 Increase/decrease . . . . . 300 s/60 s  
 Stroke . . . . . 9–32 mm (0.35 - 1.26 in.)  
 Factory set stroke. . . . . 20 mm (0.79 in.)  
 Thrust. . . . . 400 N (90 lbf)  
 Duty cycle . . . . . max. 20%/60 minutes

### Analog input

Voltage. . . . . 0–10 V  
 Impedance . . . . . min 100 kΩ

### Digital inputs VH–VC

Voltage across open input . . . . . 24 V AC  
 Current through closed input . . . . . 5 mA  
 Pulse time . . . . . min. 20 ms

### Output G1

Voltage. . . . . 16 V DC  $\pm 0.3$  V  
 Load. . . . . 25 mA, short-circuit proof

### Output Y

Voltage . . . . . 2-10 V (0-100%)  
 Load . . . . . 2 mA

### Ambient temperature

Operation . . . . .  $-10 - +50$  °C (14°F - 122°F)  
 Storage . . . . .  $-10 - +50$  °C (14°F - 122°F)  
 Ambient humidity . . . . . max. 90% RH  
 Enclosure rating . . . . . IP 54  
 Sound power level . . . . . max. 32 dBA

## Actuator for Valves

M400 is an electro-mechanical actuator for the control of two-way and three-way plug valves in:

- heating systems
- air handling systems

M400 is primarily designed for applications where the demands on actuator speed and thrust are small.

The actuator can not be equipped with Self Testing Device STS.

M400 is either controlled by an increase/decrease signal or by a modulating 0–10 V control signal.

The electronic circuitry of the actuator ensures that the running time is the same, regardless of the stroke of the valve in question.

It is easy to mount and connect the actuator. It can be mounted directly onto TAC's control valves, without any mounting kit.

For Satchwell valves a linkage is included (see PART NUMBERS on page 2)

The working range of the actuator is adjusted automatically depending on the stroke of the valve. The electronic circuitry of the actuator then takes care of the adjustment of the valve end positions.

The actuator is supplied by 24 V AC. It can provide a position indicator signal 2-10 V and a 16 V DC voltage supply for older TAC controllers.

## Standards

Emission. . . . . EN 50081-1:1992  
 Immunity . . . . . EN 50082-1:1992  
 Heat . . . . . IEC-68-2-2  
 Humidity. . . . . IEC-68-2-3  
 Cold . . . . . IEC-68-2-1  
 Vibration. . . . . IEC-68-2-6

## Material

Housing . . . . . aluminium  
 Cover . . . . . ABS/PC plastic  
 Color . . . . . aluminium/black  
 Weight . . . . . 1.8 kg (3.96 lb)  
 Dimensions . . . . . refer to the table on the next page

**PART NUMBERS**

Designation	Explanation	Part Number
M400	modulating control signal or increase/decrease signal	880-0230-030
M400-S2	modulating control signal or increase/decrease signal and end point switches	880-0231-000
M400+L2SV	modulating control signal or increase/decrease signal including a linkage for Satchwell valves	880-0620-000
M400-S2+L2SV	modulating control signal or increase/decrease signal and end point switches, including a linkage for Satchwell valves	880-0621-000

**DIMENSIONS mm (in)**

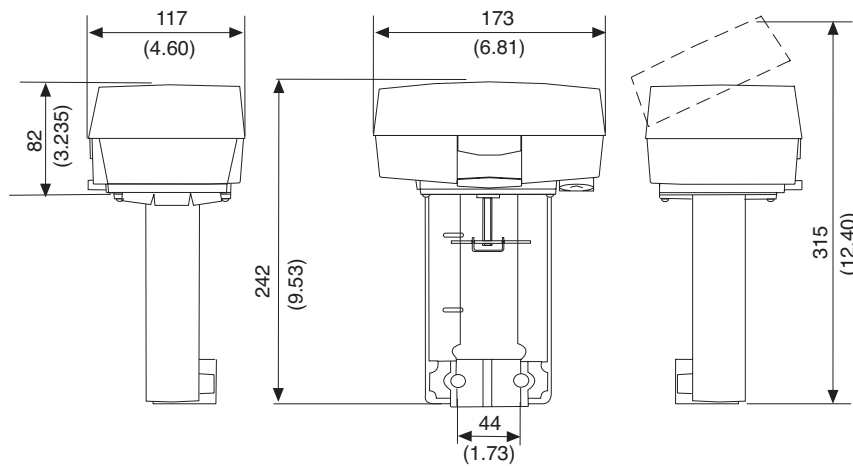

Fig 1

**FUNCTION**

**The actuator**

The brushless DC-motor of the actuator turns a screw via a gear wheel. The motor receives a control signal from a controller. The screw gets a linear movement which moves the stem of the valve.

**Control signal**

M400 can either be controlled by an increase/decrease signal or by a variable direct voltage.

If an increase/decrease signal is used, the actuator normally moves inwards on an increase signal and outwards on a decrease signal, see Settings.

**Manual operation**

There is a manual operation handle on the actuator, see figure 2. When it is lowered, the motor stops. Then, the actuator can be operated manually if the handle is turned. The actuator is supplied with the manual operation lowered.

**Position feedback**

Forta actuators are equipped with a 2–10 V DC position feedback signal, where 2 V always corresponds to the closed position and 10 V to the open position (depending of switch nr. 1).

**FUNCTION**

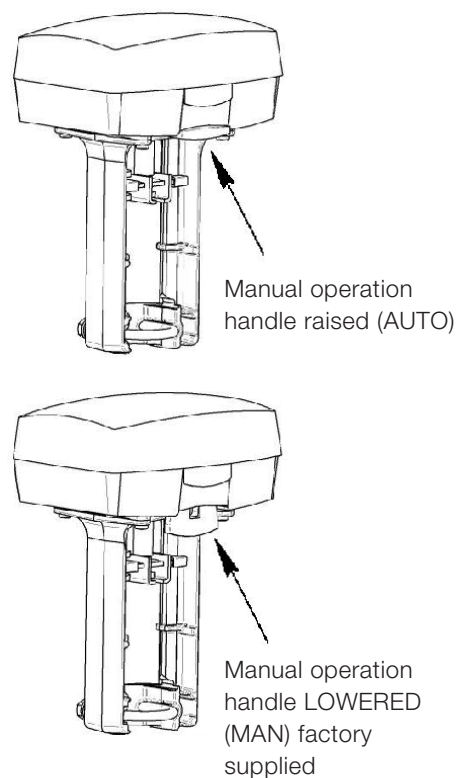

Fig 2

### End point switches

When actuators are controlled in sequence, it is possible to use the end point switches that have set positions. They will toggle when the valve is fully open or fully closed, respectively.

### MOUNTING

The actuator may be mounted horizontally, vertically and in any position in between, but not upside down, see figure 3.

N.B.! Do not use the actuator for the DN15 valves V298, V282, V294, V384, V386 and V394.

To mount the actuator on a valve, slide the actuator onto the valve neck, thus making the square nut on the valve spindle fit into the groove on the cross bar. Then slide the brace into the groove on the valve neck and secure the nuts.

### CONNECTIONS

Block	Function	Description
G	24 V AC	Supply voltage
G0	24V AC rtm	Supply voltage
X1	Input	Control signals (VH, VC short-circuited to G0)
MX	Input, neutral	
VH	Increase	Supply for RC Feedback signal
VC	Decrease	
G1	16 V DC	
Y	0-100%	

N.B.! When installed with 3 conductors, where the control signal reference is connected to G0, the motor current of the actuator will cause varying voltage loss in the cable and thus in the reference level. Forta, which has a highly sensitive control signal input, will detect the varying signal and follow it, which makes it difficult for the actuator to find a stable position.

This variation may be accepted in simplified installations on the following conditions: the cables between the controller and actuator are shorter than 100 m (328 ft.), the cross-sectional area is larger than 1.5 mm<sup>2</sup> (AWG 16) and the cables are only connected to one actuator.

Please refer to the figures labelled "Wiring Examples" for wiring instructions.

### Cable lengths

The cables to G, G0 and G1 should be max. 100 m (328 ft.) and have a cross-sectional area of min. 1.5 mm<sup>2</sup> (AWG 16).

Other cables should be max. 200 m (656 ft.) and have a cross-sectional area of min. 0.5 mm<sup>2</sup> (AWG 20).

### MOUNTING

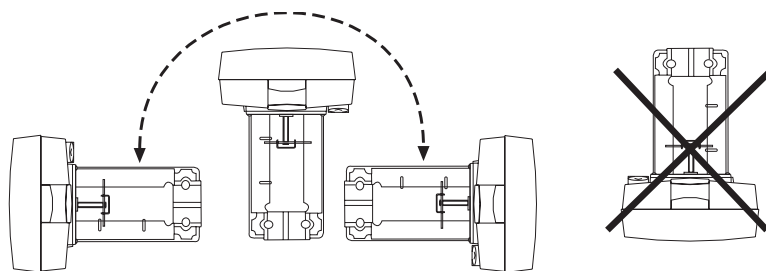
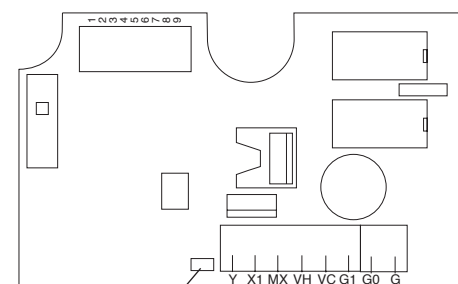
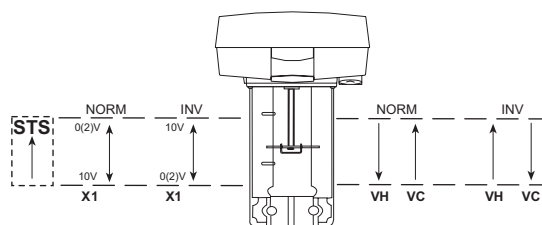

Fig 3

### CONNECTIONS



Terminal block

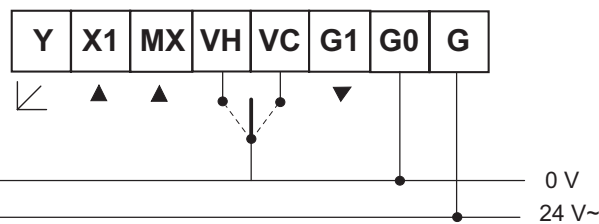
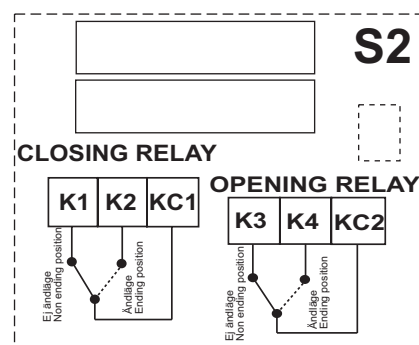

Fig 4

WIRING EXAMPLES

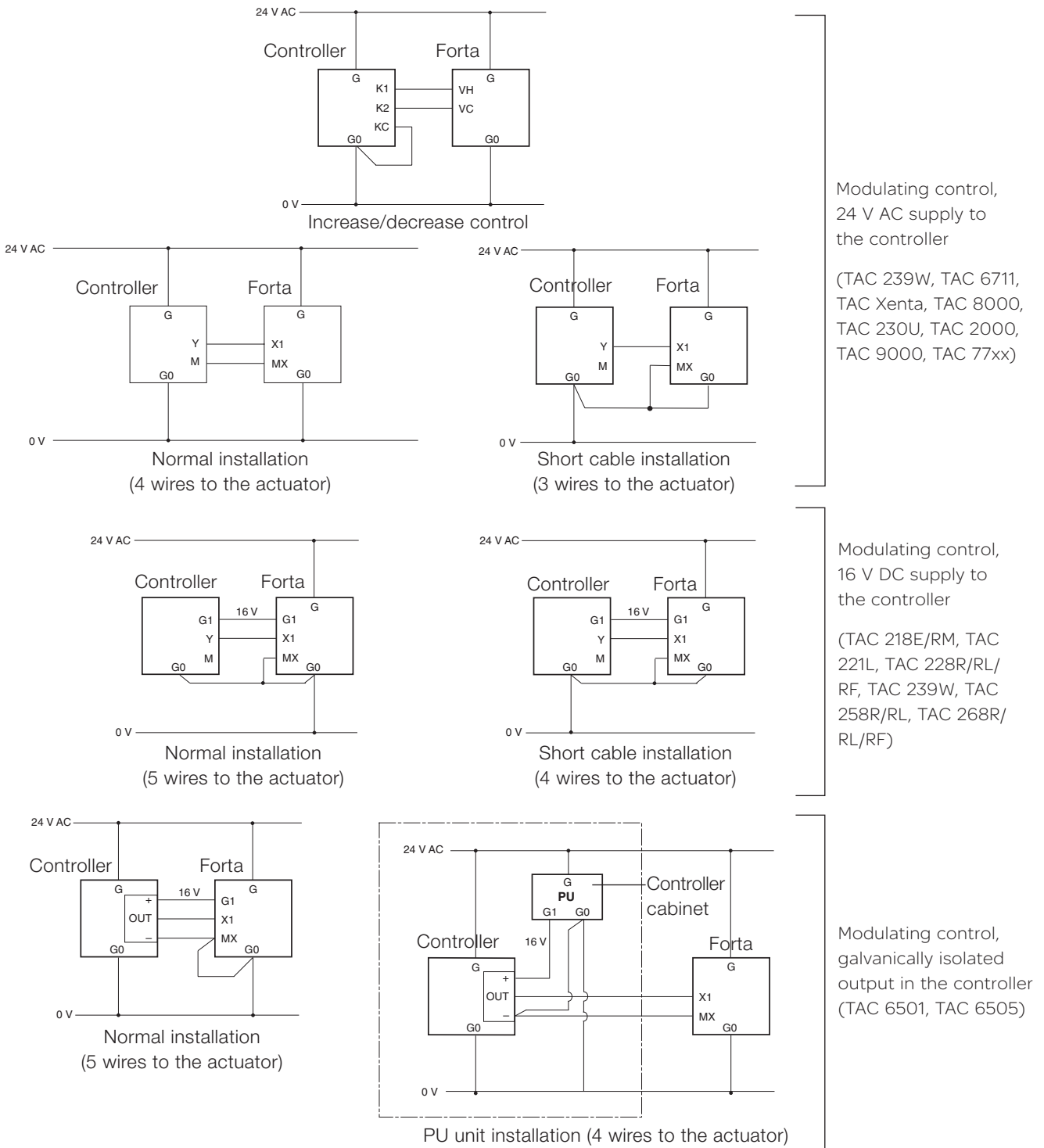

Fig 5

	Function in the "OFF" pos.	"ON" position	Description
1	In	Out	Valve closing screw direction
2	Modulating	Increase/decrease	Control (not at Sequence)
3	-	Sequence	Sequence control
4	0-10 V	2-10 V	Voltage range
5	0-5 V, 2-6 V	5-10 V, 6-10 V	Part of voltage range
6	60 s	300 s	Running time
7	Normal	Inverted	Direction of movement
8	Normal	Linear/Logarithmic	Valve characteristic
9	Operation	End position adjust (mom.)	Operation/End position adjustment

**SETTINGS**

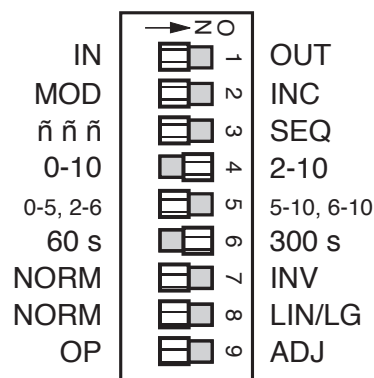

Fig 6 \*See note below

There are nine switches in a row on the circuit board. On delivery ('Factory'), all switches are in the "OFF" position.



\* **Note!**

- **0% / 60 s, 300 s / 50% has a double function, see below!**
- **STS is not available.**

**1 Valve Closing Screw Direction—IN / OUT**

IN direction of movement is used when the screw of the actuator moves inwards to close the valve.

OUT direction of movement is used when the screw of the actuator moves outwards to close the valve.



**Note! At power failure, the STS closes according to this switch.**

**Y = 2 V at close valve.**

**2 Control signal—MOD / INC**

TAC Forta can either be controlled by a variable direct voltage, a so called modulating signal (MOD), or by an increase/decrease signal (INC).

**3 Sequence or parallel control— -- / SEQ**

With sequence (or parallel) control (SEQ), two actuators/valves can be controlled by only one control signal.

For each of these you can choose which part of the voltage range to use, the upper one, 5-10 V (6-10 V) or the lower one, 0-5 V (2-6 V).

If the switch NORM / INV is in the NORM position, the higher voltage corresponds to 100% flow and the lower one to 0%.

With NORM / INV in the INV position you will get the opposite function.



**Note! If sequence or parallel control is not used, the switch --- / SEQ must be in the OFF position, as the switch MOD / INC is not valid during sequence or parallel control.**

**4 Voltage range—0-10 / 2-10**

You can choose whether to use the control signal voltage range 0-10 V or 2-10 V.

**5 Part of voltage range—0-5, 2-6 / 5-10. 6-10**

You can choose which part of a voltage range to use, the lower one 0-5 V (2-6 V) or the upper one 5-10 V (6-10 V).

If the switch is in the NORM position, the higher voltage corresponds to 100% flow and the lower one to 0%. To achieve the opposite function, the switch should be put in its INV position.

**6a Running time—60 s / 300 s**

With increase/decrease control, you can choose a running time between 60 s or 300 s.

With modulating control, the running time is always 15 s / 20 s / 30 s (or 60 s, for M400 versions only) - depending of stroke of valve.

**6b Security function—0% / 50%**

At 2-10 V control signal you can select which security function you want the actuator to have.

If the actuator is used for heating control and switch 6 is ON (50%), the actuator will open the valve halfway if the control signal disappears, e.g. if the X1 connection is unplugged.

If, instead, you want the valve closed, set switch 6 to OFF (0%).



**Note! The direction of movement is also significant. See the succeeding description.**

**7 Direction of movement—NORM / INV**

When normal direction of movement is used, the screw of the actuator moves inwards when the control voltage decreases or if the actuator gets a decrease signal.

With the switch NORM / INV, the direction of movement can be changed.

**8 Linearization—NORM / LIN/LG**

The motorized valve characteristics can be modified. If you wish for the characteristics to be affected, the setting LIN/LG will make the characteristics of an equally modified percentage (EQM) valve almost linear.

On the other hand, with LIN/LG a motorized valve equipped with a linear valve will operate with "Quick open characteristics". This means that with a small control signal, the valve will be almost completely open.

 **Note! For the actuator to register new settings of the switches, the supply voltage must be cut or the manual operation handle lowered, the settings done, and then the handle raised again.**

Please refer to illustration on page 2.

(This does not apply to the switch OP/ADJ).

**9 End position adjustment—OP / ADJ**

This switch is only used to adjust the end positions when the actuator is commissioned.

Momentarily put the switch in the ON position. The actuator will automatically find the end positions of the valve.

**ACTUATOR INSTALLATION**

Before installing it is necessary to remove the antistatic protection placed under the cover.

The switches on the circuit board should be set before the actuator is installed. There are no other switches or potentiometers that should be set or adjusted.

To make an end position adjustment, you only have to switch the switch »OP/ADJ« into its ADJ position, when the supply voltage has been turned on, and then back to its OP position.

When an end position adjustment is made, Forta closes the valve and opens it fully. The adjustment is finished by the actuator closing the valve again; the electronic circuitry then adjusts the stroke and the running time to the valve. The set

values are stored in the EEPROM of the actuator so that they will remain after a loss of voltage.

When the end position adjustment is complete, the actuator starts to control the valve according to the control signal.

**MAINTENANCE**

The actuator is maintenance-free.

**ACCESSORIES**

- S2-Forta. . . . .880-0104-000
- Circuit board M400. . . . .1-001-0673-0
- Linkage Satchwell valves L2SV. . . .880-0124-000
- See data sheet "Valves and actuators Summary" (F-10-06)

On October 1st, 2009, TAC became the Buildings Business of its parent company Schneider Electric. This document reflects the visual identity of Schneider Electric, however there remains references to TAC as a corporate brand in the body copy. As each document is updated, the body copy will be changed to reflect appropriate corporate brand changes. All brand names, trademarks and registered trademarks are the property of their respective owners.